



Type(s)
Project
Date
Notes

GENERAL INFORMATION

The High End Systems Lonestar brings the renowned brightness, quality, and performance of our bright white LED framing fixtures in a more compact package. With more than 15,400 lumens and a rich feature set, Lonestar is a perfect addition to lighting systems in theatres, television studios, cruiseships, and other small to medium-sized venues. The luminaire’s rich colors, powerful zoom, full curtain framing, diffusion, and prism effects make Lonestar a versatile and affordable tool for designers who want maximum performance from a compact-sized automated fixture.

Applications

- Houses of worship
- Nightclubs and retail installations
- Small to medium-sized performance venues
- Cruiseships and themed entertainment
- Production rental companies
- Tradeshow and ballroom AV
- Studio and film

Product Features

- Bright white LED engine
- 290 W Ultra-Bright engine
- Fixture output exceeding 15,400 lumens
- High quality 13-lens optic system
- Extremely powerful 3.8°–55° zoom
- CMY color mixing system
- Electronic linear CCT mixing control
- Ten position plus open color wheel
- Full-curtain framing system for total control of beam shaping
- 16-blade iris for extremely tight beam effects
- Two diffusion Light and Medium system with additional, optional heavy diffusion
- Nine position plus open Rotating Gobo Wheel
- Dual prisms for compound beam and projection effects
- Linearly insertable rotating animation wheel

ORDERING INFORMATION

Model	Description
LS-UB-MI 2550A1200-B	Lonestar, Black, Ultra-Bright in Molded Insert, Boxed
RC-LS 2550K1001	Road Case, Holds Up to Three (3) Lonestar Fixtures in Molded Insert

Color Options: Fixtures ship standard in black. White available by request.
Included Accessories: Fixture includes two (2) Omega brackets, one (1) fixture power cord, bare ends to powerCON® TRUE1® TOP input, and a safety cable.

Accessories

Model	Description
LS-TH 2550A1020	Top Hat, Snoot for Lonestar
LSA-HFROST 2550A2083	Heavy Frost Accessory for Lonestar
2560B7009	Fixture Power Cord Upgrade, 5-15 Edison to powerCON TRUE1 TOP, 15 A
2560B7005	Fixture Power Cord Upgrade, Stage Pin to powerCON TRUE1 TOP, 20 A
2560B7006	Fixture Power Cord Upgrade, L6-20 to powerCON TRUE1 TOP, 20 A
2560B7007	Fixture Power Cord Upgrade, L5-20 to powerCON TRUE1 TOP, 20 A
55040014	Cheeseborough 2" Alloy 1/2 Coupler Truss Clamp
67040010	Mini-Claw™



PRODUCT SPECIFICATIONS

Source

Engine	Ultra-Bright
LED Details	290 W
Field Lumens	See photometrics on page 4
Max Integrating Sphere Lumens	15,400 lumens
LPW	53
LED Life	50,000 hours
Native CCT	7000 K

Color

Color Mixing	Cyan, magenta, yellow, CTO-linear
Color Temperature	Variable down to 2200 K
Color Wheel	Ten (10) dichroic colors plus open

Optical

Beam Angle Range	3.8°–55°
Gate Size	15.8 mm
Aperture Size	120 mm
Pattern Projection	Rotating and indexable wheel with nine (9) patterns plus open
Animation	Bi-directional animation wheel
Prism	Five facet star and four facet linear rotating prism with simultaneous insertion
Diffusion	Light and medium diffusion Optional heavy diffusion in prism slot
Iris	16-blade iris
Framing	Four-plane, full-curtain framing system with 120° module rotation
Flicker Control/Hz Range	2.4 kHz and 16 kHz

Control

Input Method	DMX (5-pin) or Ethernet
Protocols	DMX via RS-485 Art-Net or sACN via Ethernet
Ethernet Pass-Thru	Passive Ethernet in and thru with and without power
Data Conversion	Patented data conversion system for: DMX to Ethernet Ethernet to DMX
Modes (Footprint)	Standard or Trifusion (48 channels)
RDM Functions	Yes
UI Type	Full color graphical UI with 6-button navigational control
Local Control	Yes
Dimming Performance	16-bit, DMX controlled

Notes: All LED sources experience some lessening of light output and some color shift over time. LED output will vary with thermal conditions. Thermal conditions can be affected by ambient temperatures and orientation

Electrical

Voltage Range	100–240 V 50–60 Hz
Input Method	powerCON TRUE1 TOP
Wattage (Standard)	615 W
Current (Max)	6.2 A @ 100 V
Inrush (First Half Cycle)	120 V: 56.8 A 230 V: 78.0 A
Fixtures per Circuit	2 fixtures (15 A power thru connector) 3 fixtures (R20 module or similar) Note: TRUE1 TOP connector rated for 20 A (120 V / 60 Hz) and 16 A (240 V / 50 Hz)

Thermal

Ambient Operating Temp	-10°–40°C (14°–104°F)
Fan Mode	Standard, Studio, and Linear Continuous control channel
Stationary Noise	TBD

Physical

Pan and Tilt Range	540° pan, 251° tilt
Max Pan/Tilt Speed	360° in 2.306 s/180° in 1.26 s
Materials	Steel and aluminum frame with molded plastic covers
Color Options	Black, white by request
Mounting Options	Any orientation
IP Rating	IP20
Weight	22.7 kg (50 lb)
Included Accessories	powerCON TRUE1 TOP to bare end fixture tail Two (2) clamp brackets Safety cable

Warranty

Fixture Warranty	Five (5) years for light engine Two (2) years for complete fixture
Warranty Details	etcconnect.com/Support/Warranty.aspx

Regulatory & Compliance

Regulatory Standards	Listed to UL 1573 Certified to CSA STD. C22.2 No: 166 FCC Class A EAC
CE compliance declared to these standards	Safety: EN 60598-1, EN 60598-2-17, EN 62031, EN 62471 EMC: EN 55015, EN 61547, EN 61000-3-2, EN 61000-3-3
Complies to the ROHS directive	Yes

Safety

Safety	Minimum distance to illuminated surface = 3.0 m (10 ft) Minimum distance from fixture head to combustible materials = 0.1 m (4.0 in)
--------	---

FEATURE DETAILS

Rotating Gobo Details







Outside Diameter	17.5 mm (0.69 in)
Image Diameter	13 mm (0.51 in)
Materials	0.5 mm aluminum 1.1 mm glass Borofloat®



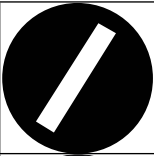

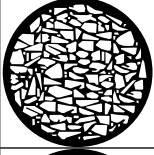
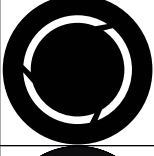

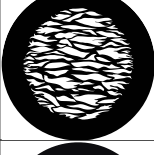
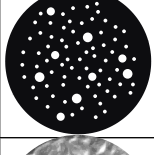
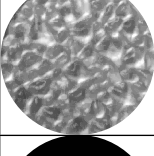

Color Wheel Details

Shape	Fixed wedge
Materials	1.1 mm glass Borofloat

Animation Wheel Details

Movement	Bi-directional continuous rotation
Materials	0.6 mm aluminum

	1 - Bar
	2 - Starvolver
	3 - Fracked
	4 - Broken Tunnel
	5 - Seashell
	6 - Glacial
	7 - Shower
	8 - Ice
	9 - Branch Out

	1 - Red
	2 - Blue
	3 - Green
	4 - Yellow
	5 - Purple
	6 - TM-30
	7 - Lavender
	8 - Half CTO
	9 - Full CTO
	10 - Dark Blue

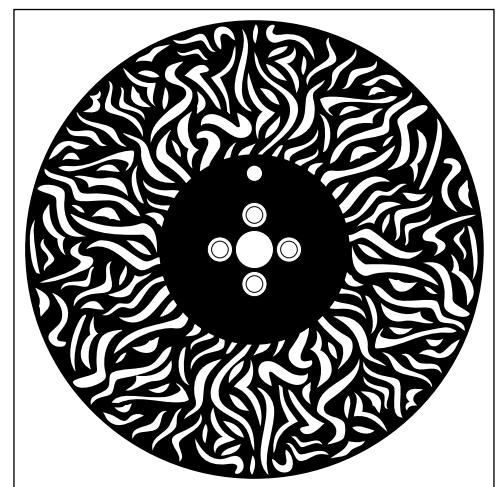

PHOTOMETRIC DATA

Lonestar - Ultra-Bright

	Degree	Candela	Field Lumens	Power Usage	Lumens Per Watt
Narrow	3.8°	1,771,100	5,209	290 W	18
Medium	26°	143,900	12,073	290 W	42
Wide	55°	30,000	10,700	290 W	37

Narrow - 3.8°

Throw Distance	10 ft 3.0 m	20 ft 6.1 m	30 ft 9.1 m	50 ft 15.2 m	200 ft 61 m
Field Diameter	0.7 ft 0.21 m	1.3 ft 0.41 m	2.0 ft 0.61 m	3.3 ft 1.02 m	13.3 ft 4.05 m
Illuminance (fc)	17,711	4,428	1,968	709	45
Illuminance (lux)	190,564	47,641	21,174	7,623	476

Medium - 26°

Throw Distance	10 ft 3.0 m	20 ft 6.1 m	30 ft 9.1 m	50 ft 15.2 m	200 ft 61 m
Field Diameter	4.6 ft 1.41 m	9.2 ft 2.82 m	13.9 ft 4.23 m	23.1 ft 7.04 m	92.3 ft 28.15 m
Illuminance (fc)	1,439	360	160	58	4
Illuminance (lux)	15,479	3,870	1,720	619	39

Wide - 55°

Throw Distance	10 ft 3.0 m	20 ft 6.1 m	30 ft 9.1 m	50 ft 15.2 m	200 ft 61 m
Field Diameter	10.4 ft 3.18 m	20.8 ft 6.35 m	31.2 ft 9.53 m	52.1 ft 15.87 m	208.2 ft 63.47 m
Illuminance (fc)	300	75	34	12	1
Illuminance (lux)	3,226	807	358	129	8

To determine center beam illumination in footcandles at any throw distance, divide candela by the throw distance squared.

Metric conversions: For meters, multiply feet by 0.3048.
For lux, multiply footcandles by 10.76.

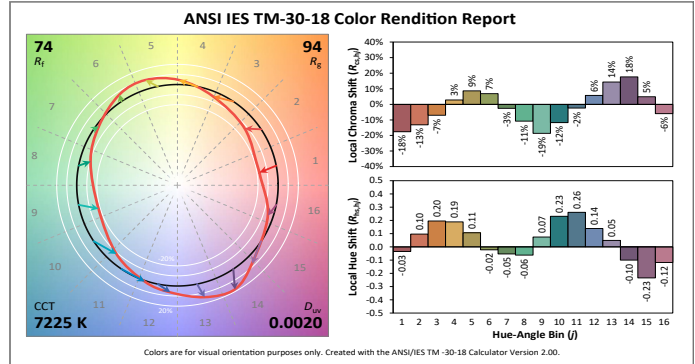

Additional Color Metrics	
CRI R_a (R_9)	73 (-24)
TLCI	50

Product Dimensions

Model	Height		Width		Depth	
	in	mm	in	mm	in	mm
Lonestar**	23.6	600	14.5	368	8.7	221
Lonestar in Box with Molded Insert	26.6	676	21.1	536	14.9	378

Product Weight

Model	Weight	
	lb	kg
Lonestar**	50.0	22.7
Lonestar in Box with Molded Insert	77	34.9

**Does not include mounting hardware

Lonestar

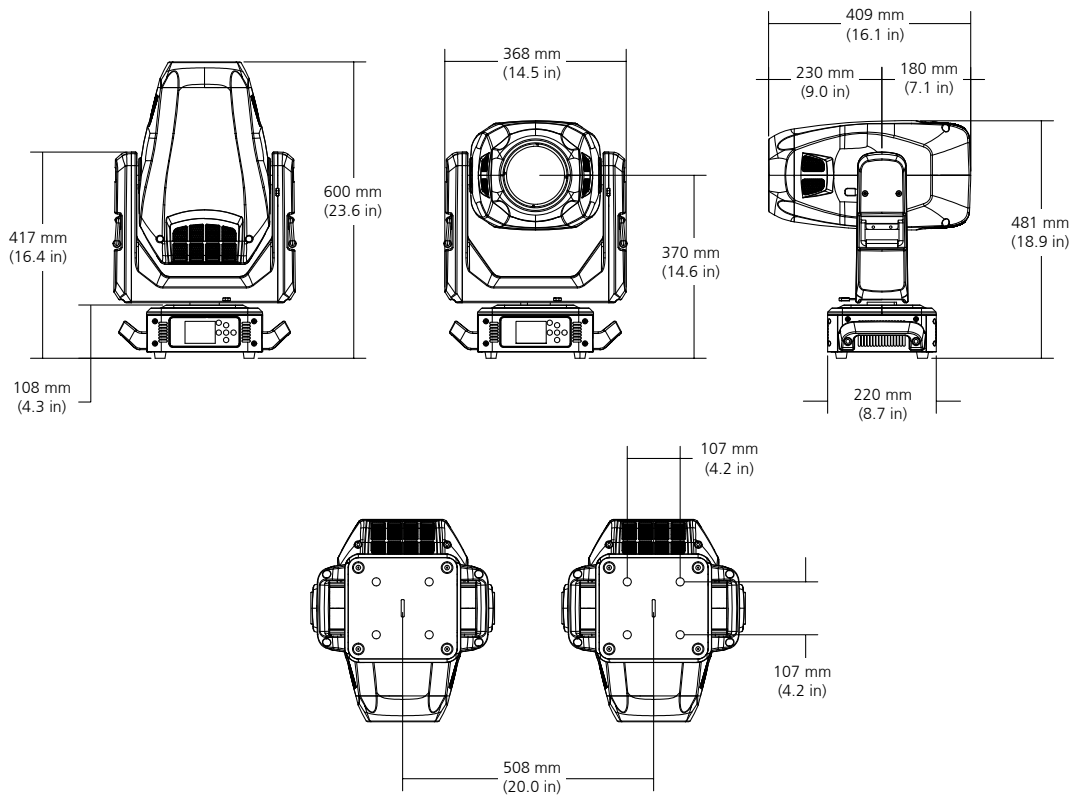

Power Table

VAC	Amps	Hz	Watts	VA	PF
100	6.2	50	615	619	0.99
120	5.1	60	611	614	0.99
200	2.9	50	570	602	0.97
208	2.9	60	583	602	0.97
220	2.7	50	579	599	0.97
230	2.6	50	580	596	0.96
240	2.5	60	575	607	0.95

ADDITIONAL ORDERING INFORMATION

Additional Accessories

Model Number	Description
2550A3005	Extra Omega brackets
H7300105	Galvanized safety cable with spring snap

Molded Case Insert Dimensions

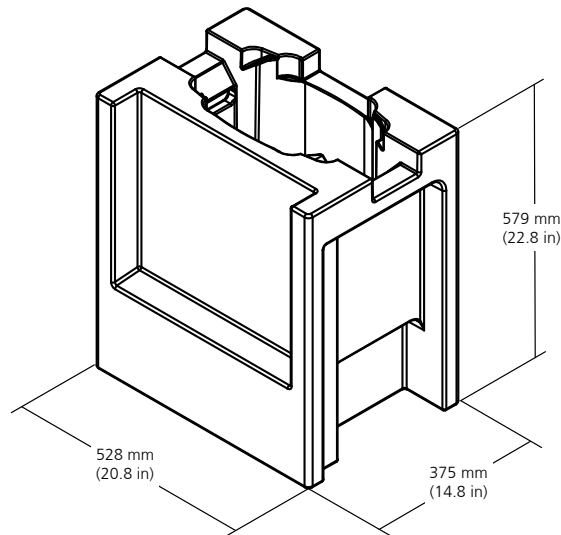

Optional Roadcase Dimensions

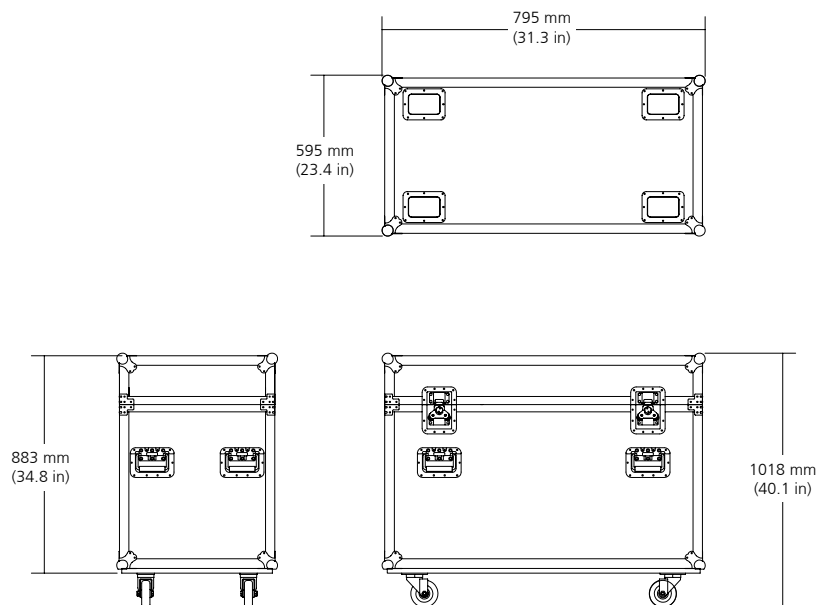

Corporate Headquarters • Middleton, WI USA

Global Offices • London, UK • Rome, IT • Holzkirchen, DE • Paris, FR • Hong Kong
Dubai, UAE • Singapore • New York, NY • Orlando, FL • Los Angeles, CA • Austin, TX

Copyright©2021 ETC. All Rights Reserved. All product information and specifications subject to change. Rev A 2021-08

*Trademark and patent info: etcconnect.com/ETC

etcconnect.com

