

# Photometric Test Report



## ECLFWDY

High quality Full White LED ellipsoidal  
in Daylight version

## CONTENTS

Table of contents	2
Testing process	3
Preset Full on	
Beam angle PRL5	4
Beam angle PRL10	9
Beam angle PRL14	14
Beam angle PRL19	19
Beam angle PRL26	24
Beam angle PRL36	29
Beam angle PRL50	34
Beam angle PRL70	39
Beam angle PRL15-30 Max Zoom	44
Beam angle PRL15-30 Min Zoom	49
Beam angle PRL25-50 Max Zoom	54
Beam angle PRL25-50 Min Zoom	59

## TESTING PROCESS

Prolights has its own optical testing laboratory in order to provide accurate photometric reports for its lighting products. The testing laboratory contains certain variety of precise lighting measurement systems that ensure an optimal reading of all the characteristic parameters of the lighting devices. All measurements are made at a controlled room temperature of 20°C without any external light sources. This photometric report is obtained through the data measured by a high precision measurement system and analyzed by a dedicate software.

### Prolights measurement instrument

Prolights measurement instrument is a complete measurement system for any light source. It's equipped with two-axis goniometer, that enables to measure the full 3D distribution field of the light source. This instrument measures the light intensity, the beam angle and the most significative colors parameters, like color temperature, spectral distribution, CRI, CQS, TM-30 with a very high accuracy rate.

**Please Note:** All measurements are made with light source at operating temperature. Before starting the measurement, the instrument analyzes the process of the light source during the heating phase. The measuring process of all the parameters begins only when the light emission is stable, that is with a variation of less than 0.5% in a 15 minutes time frame.

### Prolights measurement software

The software provides user friendly interface for the operator who does the measurements, and it also analyzes and processes all the collected data by the instrument. With this software it is possible to see the measured data in real-time and it is possible to examine all the measured data and graphics afterwards as well. All information is collected in a specific Prolights template, and the software creates also IES and LDT files, which are widely used to transfer the photometric data, and to develop lighting system.

Additionally, the fixtures are rechecked using various hand-held instruments like Sekonic C-700 and Gossen Mavospec Base, this is done to ensure, that the data in the photometric report are as accurate as possible.



Total lumen output:

7231 lm

Peak candela output:

898885 cd

Light quality:

CRI: 97,2

Color temperature:

5591 K

PRODUCT NAME:

ECLFWDY

MEASURAMENT CONDITIONS:

Beam angle:

PRL5

Target:

Cold White

Operator:

Paolo Carvone

Date and time:

17/11/2020 14:14:30

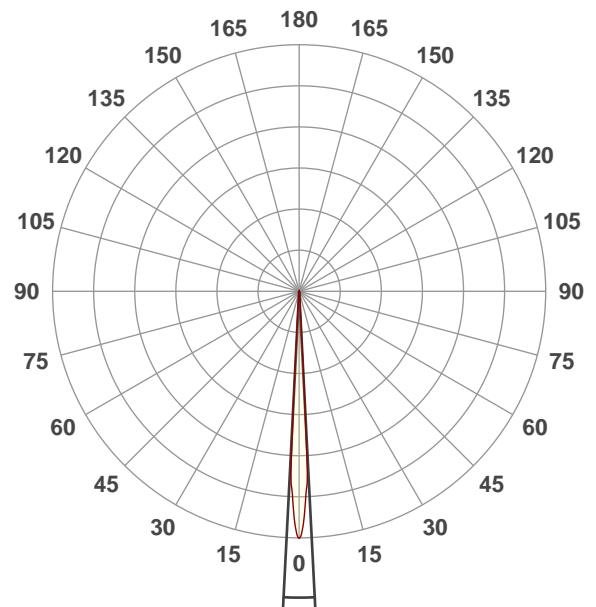

Beam angle 50%: 5,8°

Field angle 10%: 7,1°

Cut off angle 2.5%: 8,2°

Spectra

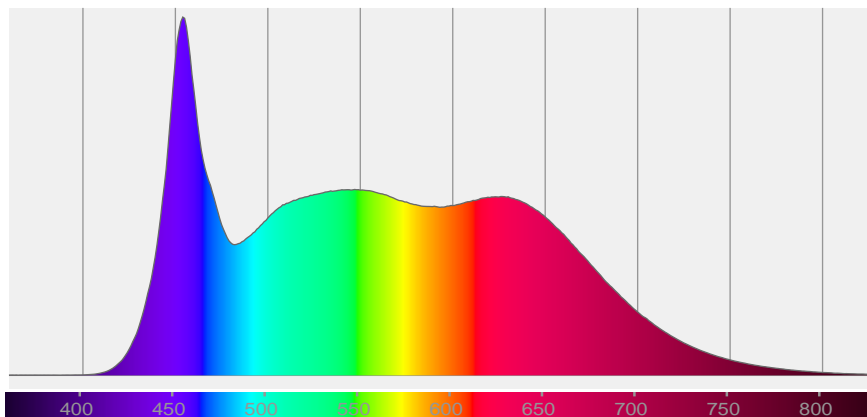

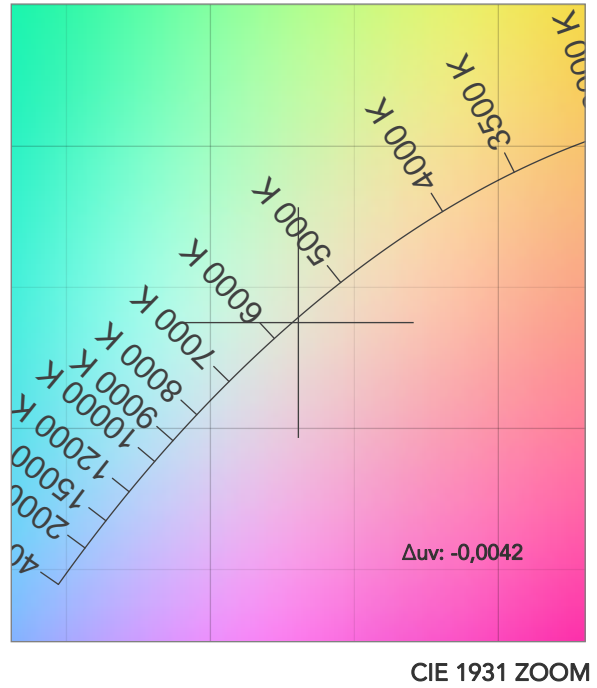
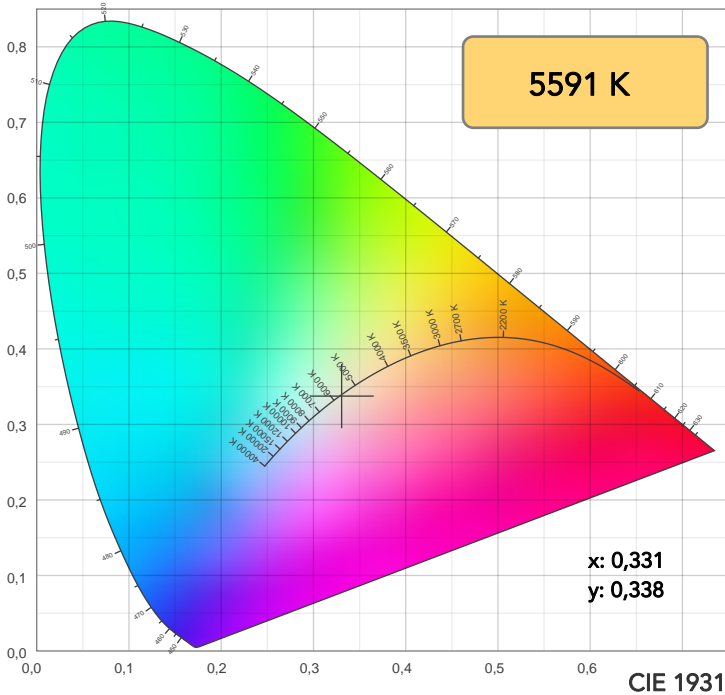

TM30: 91,6

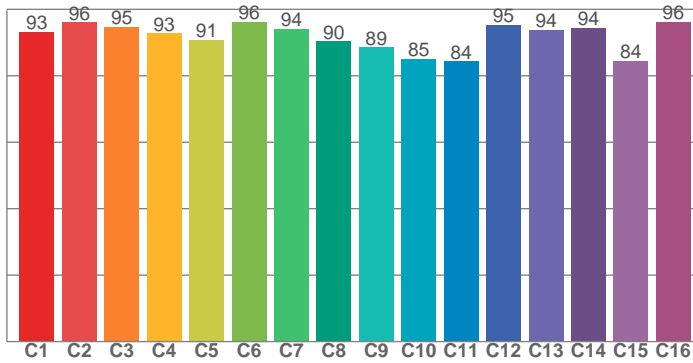

CRI: 97,2 (R1-R8)

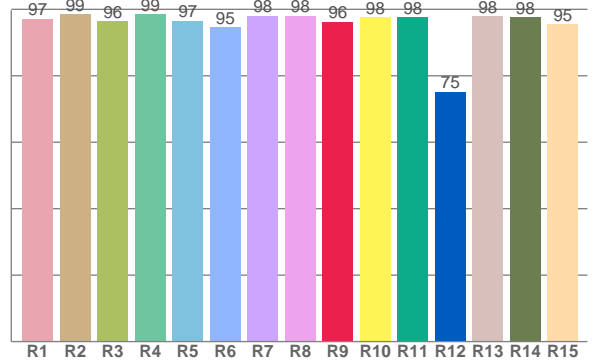

CRI R values, only R1-R8 are used to calculate final CRI value

R1	R2	R3	R4	R5	R6	R7	R8	R9	R10	R11	R12	R13	R14	R15
97,1	98,5	96,4	98,6	96,6	94,5	98,1	98,1	96,3	97,6	97,7	75,2	98,0	97,6	95,4

TM30 C values, 16 binned values out of total of 99 C values

C1	C2	C3	C4	C5	C6	C7	C8	C9	C10	C11	C12	C13	C14	C15	C16
93,1	96,1	94,7	92,7	90,8	96,3	94,1	90,3	88,5	85,1	84,3	95,4	93,8	94,4	84,4	96,2

CQS Q values

Q1	Q2	Q3	Q4	Q5	Q6	Q7	Q8	Q9	Q10	Q11	Q12	Q13	Q14	Q15
94,9	99,6	88,1	86,7	91,7	95,5	97,5	98,7	97,0	96,4	95,5	96,2	97,1	97,8	97,0

CQS: 94,1

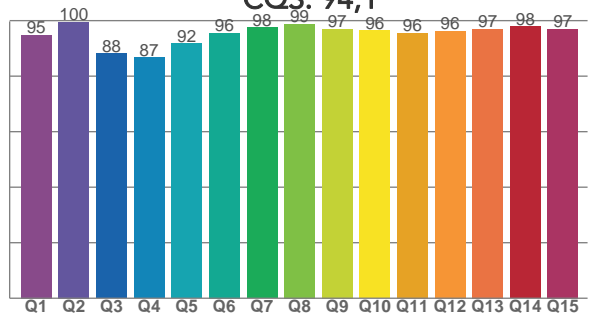

COLOR PARAMETERS

Color temperature	Color rendering index	Red component	Color fidelity	Color gamut	Color quality scale	Television lighting index	Color coordinate cie 1931	Color coordinate cie 1931	Color deviation from black body
CCT	CRI	CRI R9	TM30 Rf	TM30 Rg	CQS	TLCI	x	y	Δuv
5591 K	97,2	96,3	91,6	100,3	94,1	98	0,331	0,338	-0,0042

# TM30 DETAILS

**Rf 91,6**  
Fidelity index Rf

**Rg 100,3**  
Gammut index

Hue Bin	R <sub>f</sub>	Graphic shifts (%)	
		Chroma	Hue
1	93	-1%	1%
2	96	0%	1%
3	95	0%	0%
4	93	-2%	-1%
5	91	-4%	0%
6	96	-1%	0%
7	94	-3%	2%
8	90	-2%	5%
9	89	-2%	9%
10	85	0%	8%
11	84	4%	8%
12	95	2%	1%
13	94	4%	0%
14	94	1%	-1%
15	84	9%	-7%
16	96	0%	0%

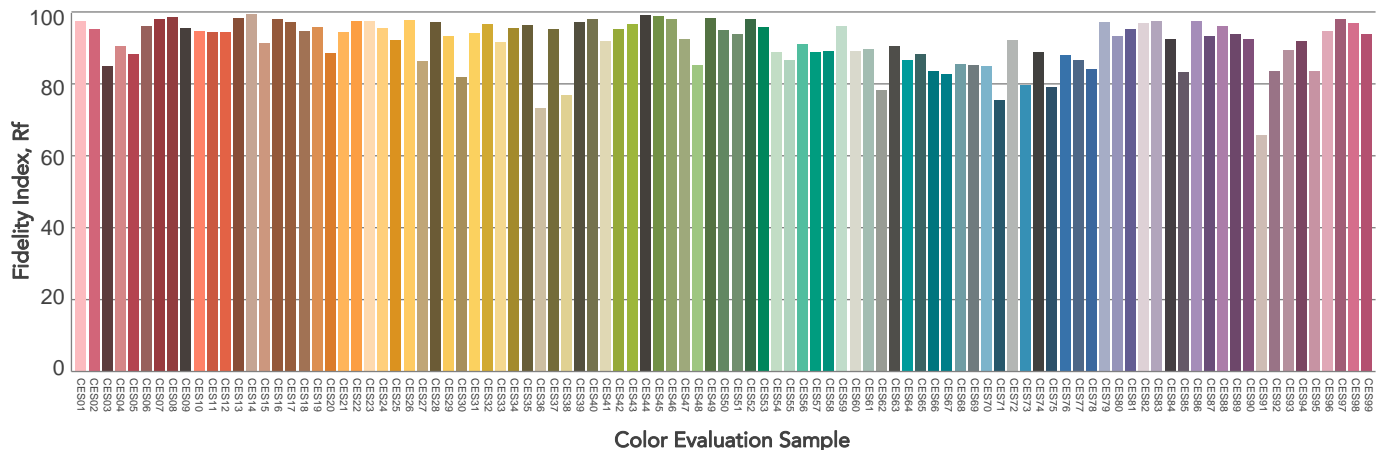
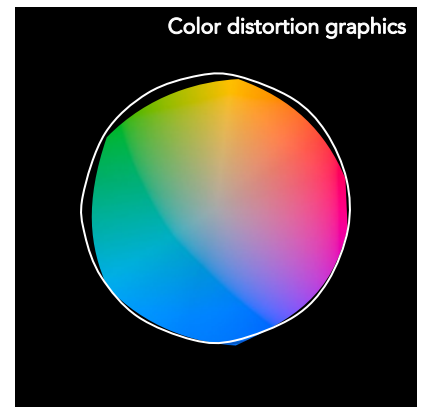
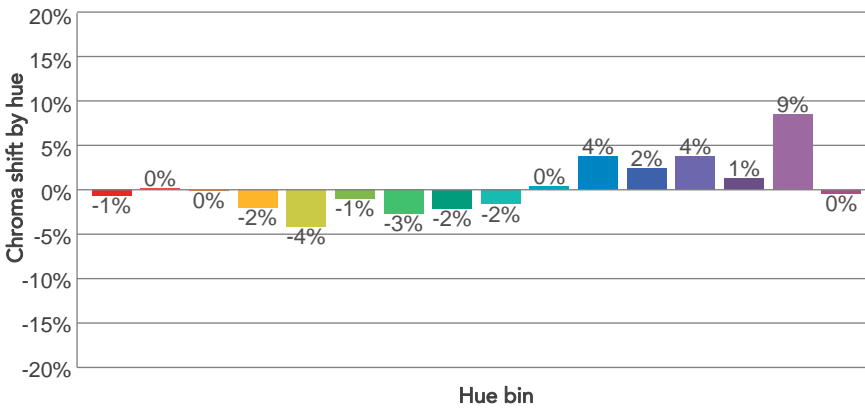
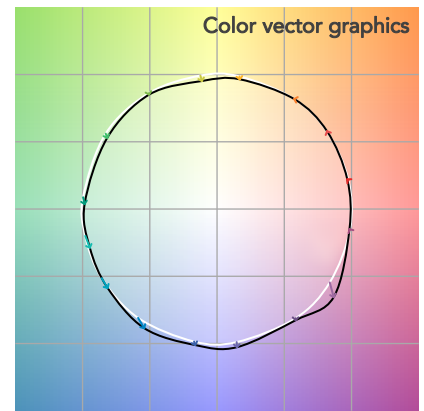
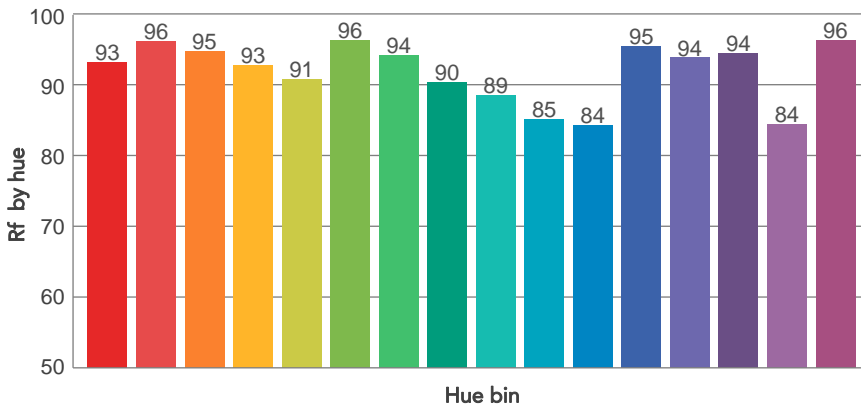
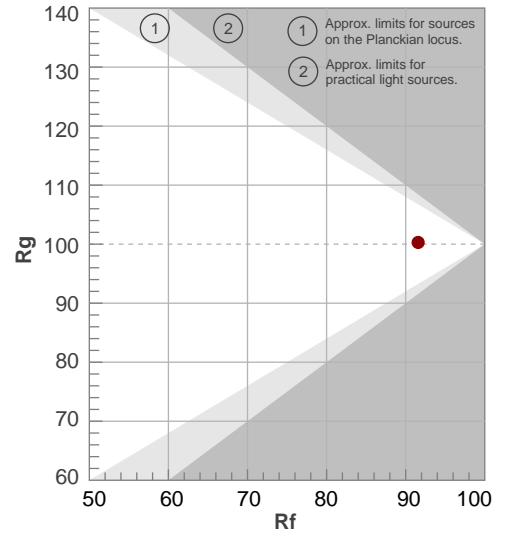

# BEAM DETAILS



Beam angle 50%	Field angle 10%	Cut off angle 2,5%	Intensity ratio in 120° cone	Intensity ratio in 90° cone
5,8°	7,1°	8,2°	100,0%	100,0%

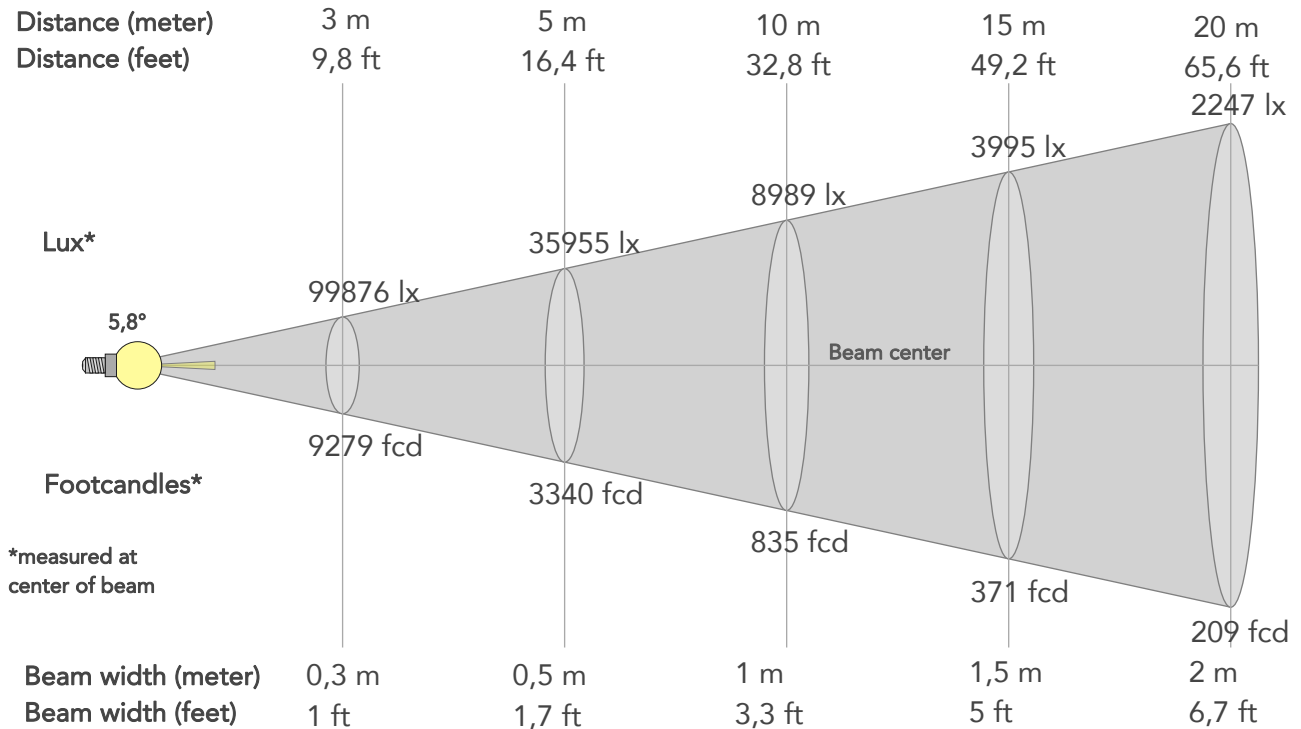

## BEAM INTENSITIES AND WIDTHS

Distance	1m	2m	3m	4m	5m	7,5m	10m	15m	20m	25m	30m	40m	50m
Distance	3,3ft	6,6ft	9,8ft	13,1ft	16,4ft	24,6ft	32,8ft	49,2ft	65,6ft	82ft	98,4ft	131,2ft	164ft
Lux	898885lx	224721lx	99876lx	56180lx	35955lx	15980lx	8989lx	3995lx	2247lx	1438lx	999lx	562lx	360lx
Footcand.	83509fcd	20877fcd	9279fcd	5219fcd	3340fcd	1485fcd	835fcd	371fcd	209fcd	134fcd	93fcd	52fcd	33fcd
Beam wid.	0,1m	0,2m	0,3m	0,4m	0,5m	0,8m	1m	1,5m	2m	2,5m	3,1m	4,1m	5,1m
Beam wid.	0,3ft	0,7ft	1ft	1,3ft	1,7ft	2,5ft	3,3ft	5ft	6,7ft	8,4ft	10ft	13,4ft	16,7ft

## LINEAR DISTRIBUTION DIAGRAM

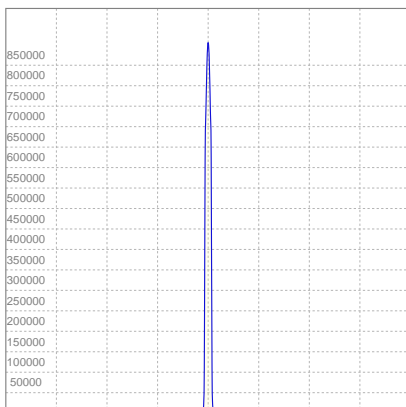

## ELECTRICAL SPECIFICATIONS

Input voltage	Input current	Input power	Effeciency
224V	1,23A	265,2W	27lm/W
<b>Power Fc</b>			
<b>0,97</b>			

## ISO CANDELA DIAGRAM

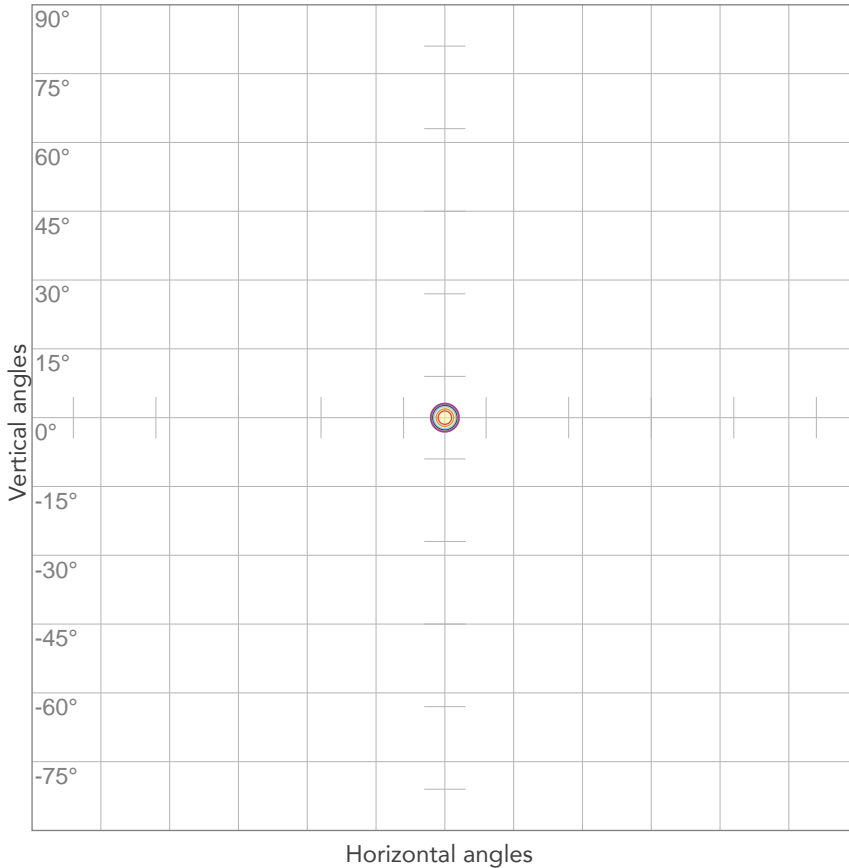

10%	89889 cd
20%	179777 cd
30%	269666 cd
40%	359554 cd
50%	449443 cd
60%	539331 cd
70%	629220 cd
80%	719108 cd

Conditions:  
 Number of c-planes: 2  
 Candela at center: 898885 cd

## ISO LUX DIAGRAM

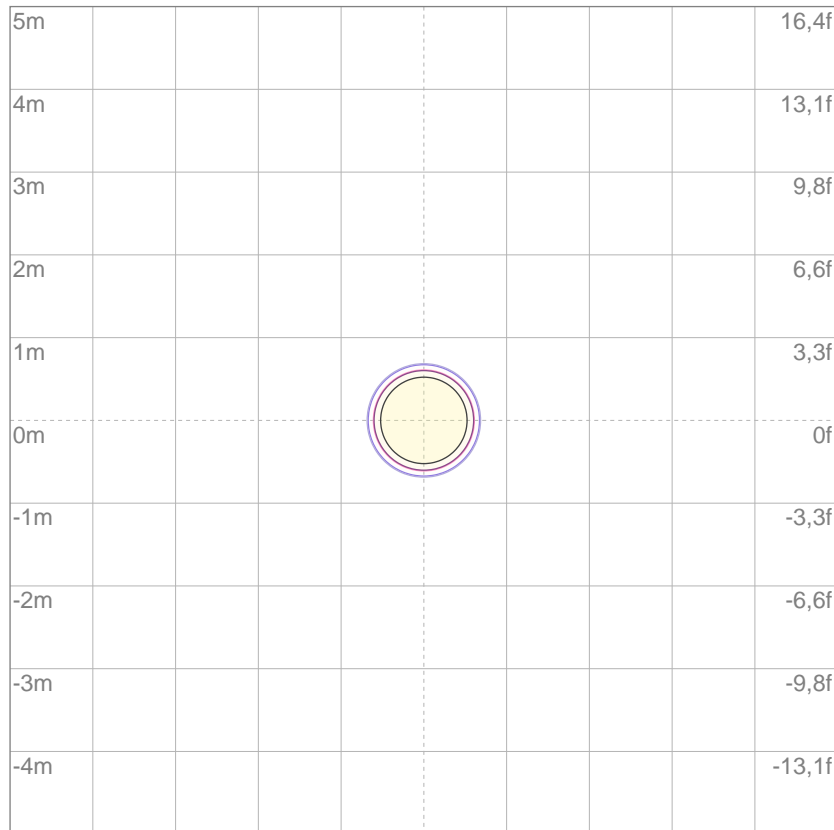

3%	270 lx
5%	449 lx
10%	899 lx
30%	2697 lx
50%	4494 lx

Conditions:  
 Number of c-planes: 2  
 Lux at center: 8989 lx

*Lux distribution on a surface when lamp is mounted at 10 meters from the surface.*

Mounting height: 10 meters (33 feet)





Total lumen output:

8828 lm

Peak candela output:

402077 cd

Light quality:

CRI: 97,2

Color temperature:

5628 K

**PRODUCT NAME:**

ECLFWDY

**MEASURAMENT CONDITIONS:**

Beam angle:

PRL10

Target:

Cold White

Operator:

Paolo Carvone

Date and time:

17/11/2020 14:16:44

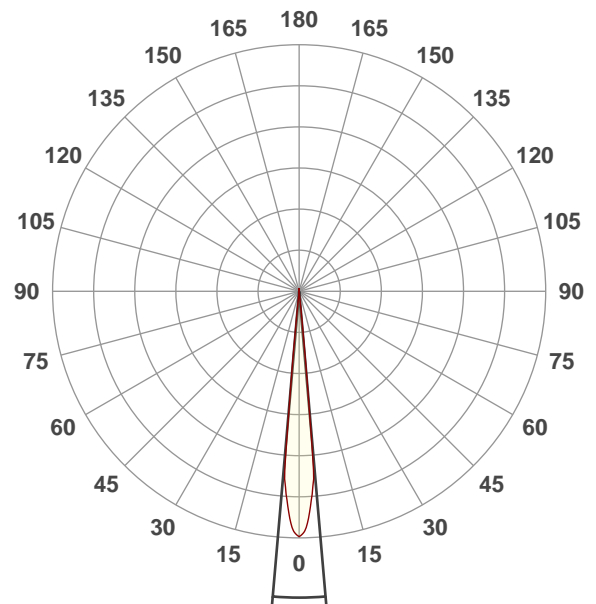

Beam angle 50%: 9,9°

Field angle 10%: 11,4°

Cut off angle 2.5%: 11,8°

Spectra

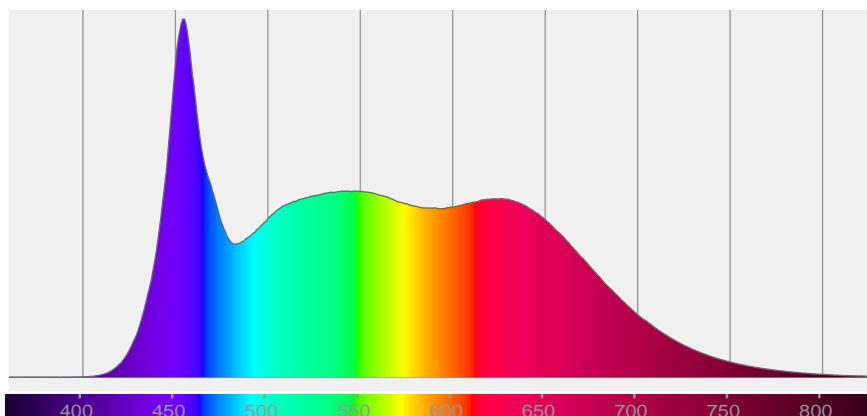

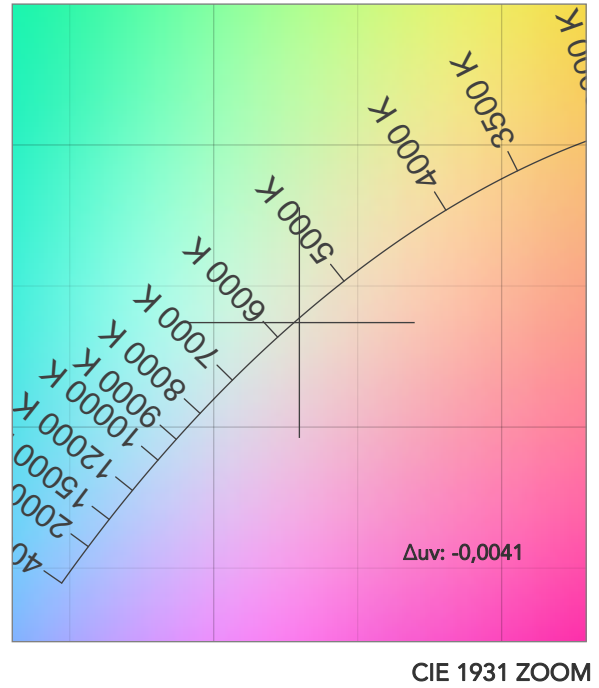
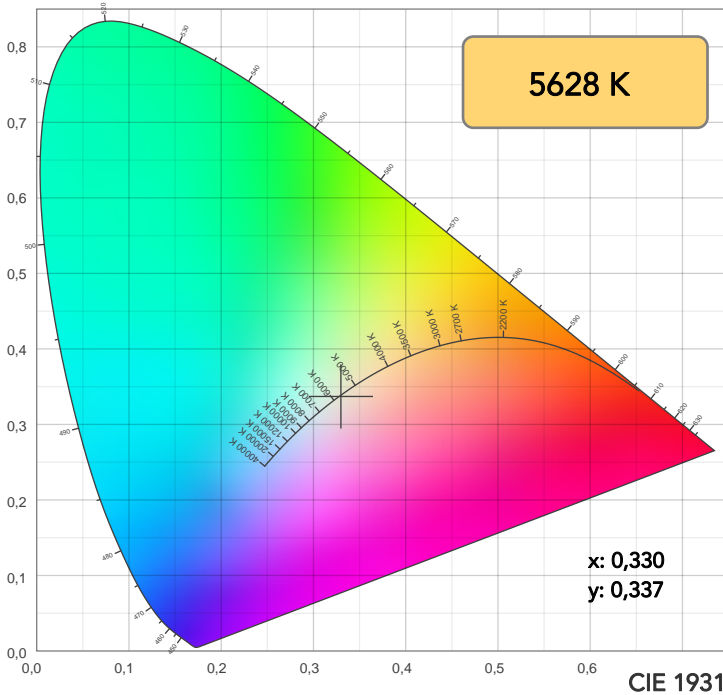

TM30: 91,5

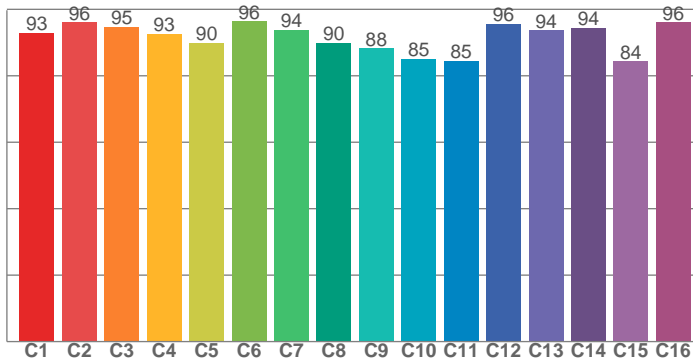

CRI: 97,2 (R1-R8)

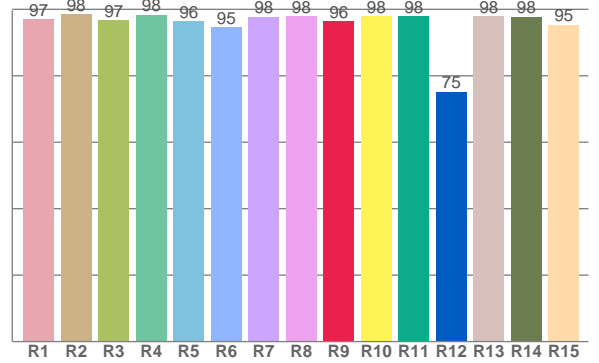

CRI R values, only R1-R8 are used to calculate final CRI value

R1	R2	R3	R4	R5	R6	R7	R8	R9	R10	R11	R12	R13	R14	R15
97,1	98,5	96,7	98,3	96,5	94,6	97,8	97,9	96,4	97,9	97,9	75,2	97,9	97,8	95,4

TM30 C values, 16 binned values out of total of 99 C values

C1	C2	C3	C4	C5	C6	C7	C8	C9	C10	C11	C12	C13	C14	C15	C16
93,0	96,1	94,8	92,6	89,9	96,3	93,8	89,9	88,3	85,0	84,5	95,5	93,6	94,4	84,4	96,1

CQS Q values

Q1	Q2	Q3	Q4	Q5	Q6	Q7	Q8	Q9	Q10	Q11	Q12	Q13	Q14	Q15
94,5	99,5	88,4	86,8	91,6	95,3	97,7	98,7	97,2	96,6	95,8	96,4	97,1	97,8	96,9

CQS: 94,2

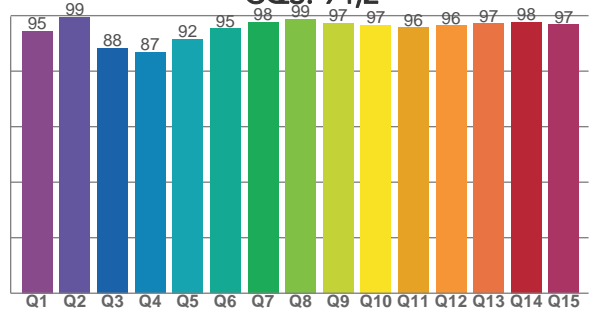

COLOR PARAMETERS

Color temperature	Color rendering index	Red component	Color fidelity	Color gamut	Color quality scale	Television lighting index	Color coordinate cie 1931	Color coordinate cie 1931	Color deviation from black body
CCT	CRI	CRI R9	TM30 Rf	TM30 Rg	CQS	TLCI	x	y	Δuv
5628 K	97,2	96,4	91,5	100,1	94,2	98	0,330	0,337	-0,0041

# TM30 DETAILS

**Rf 91,5**  
Fidelity index Rf

**Rg 100,1**  
Gammut index

Hue Bin	R <sub>f</sub>	Graphic shifts (%)	
		Chroma	Hue
1	93	-1%	1%
2	96	0%	1%
3	95	0%	0%
4	93	-2%	-1%
5	90	-4%	0%
6	96	-1%	0%
7	94	-3%	2%
8	90	-2%	5%
9	88	-2%	9%
10	85	0%	9%
11	85	4%	8%
12	96	2%	1%
13	94	4%	-1%
14	94	1%	-1%
15	84	8%	-8%
16	96	-1%	1%

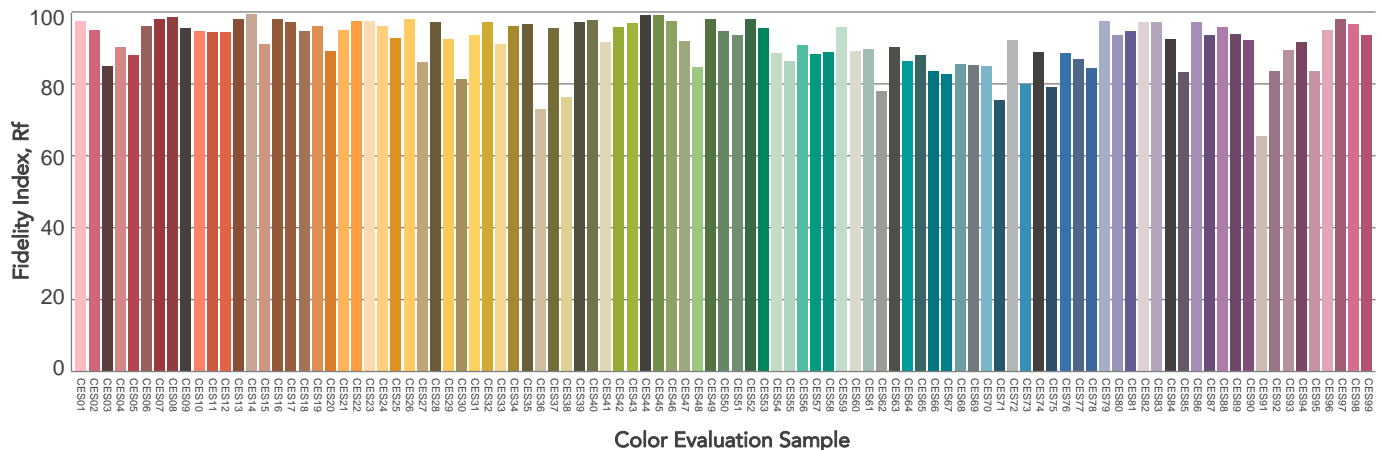
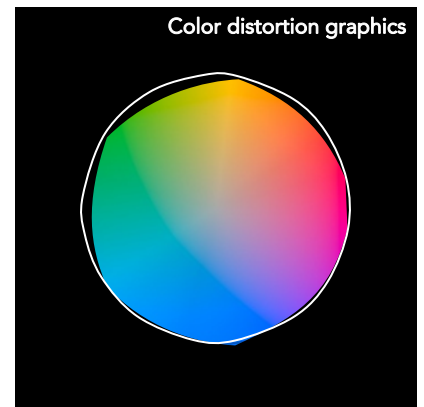
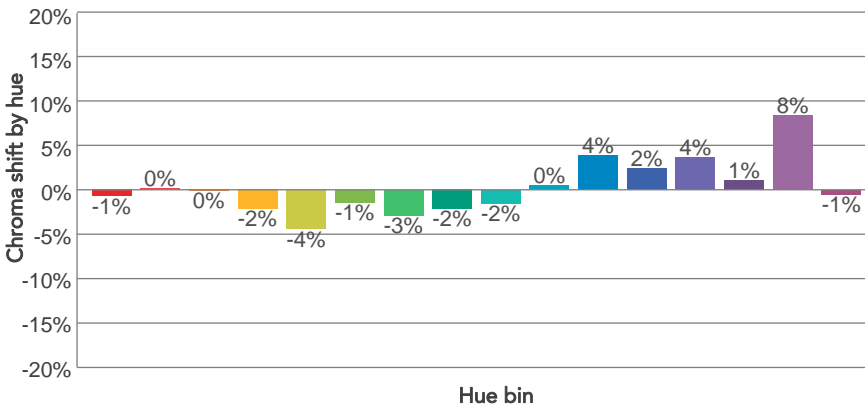
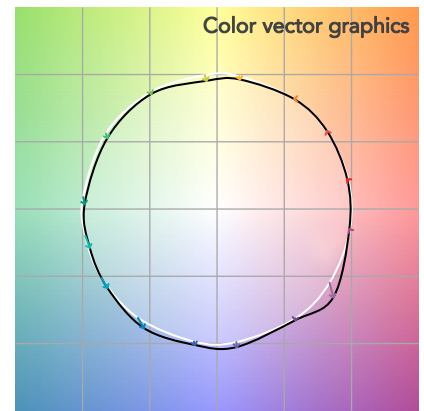
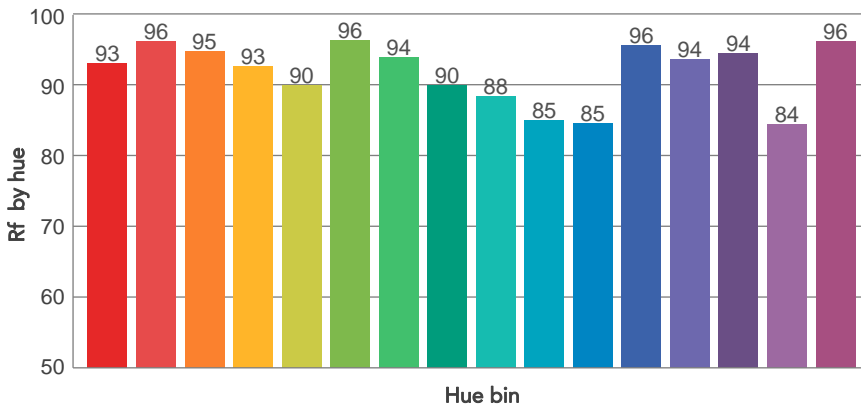
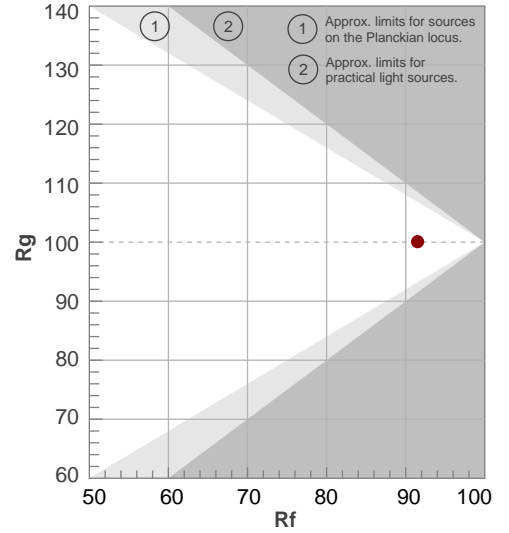

# BEAM DETAILS



Beam angle 50%	Field angle 10%	Cut off angle 2,5%	Intensity ratio in 120° cone	Intensity ratio in 90° cone
9,9°	11,4°	11,8°	100,0%	100,0%

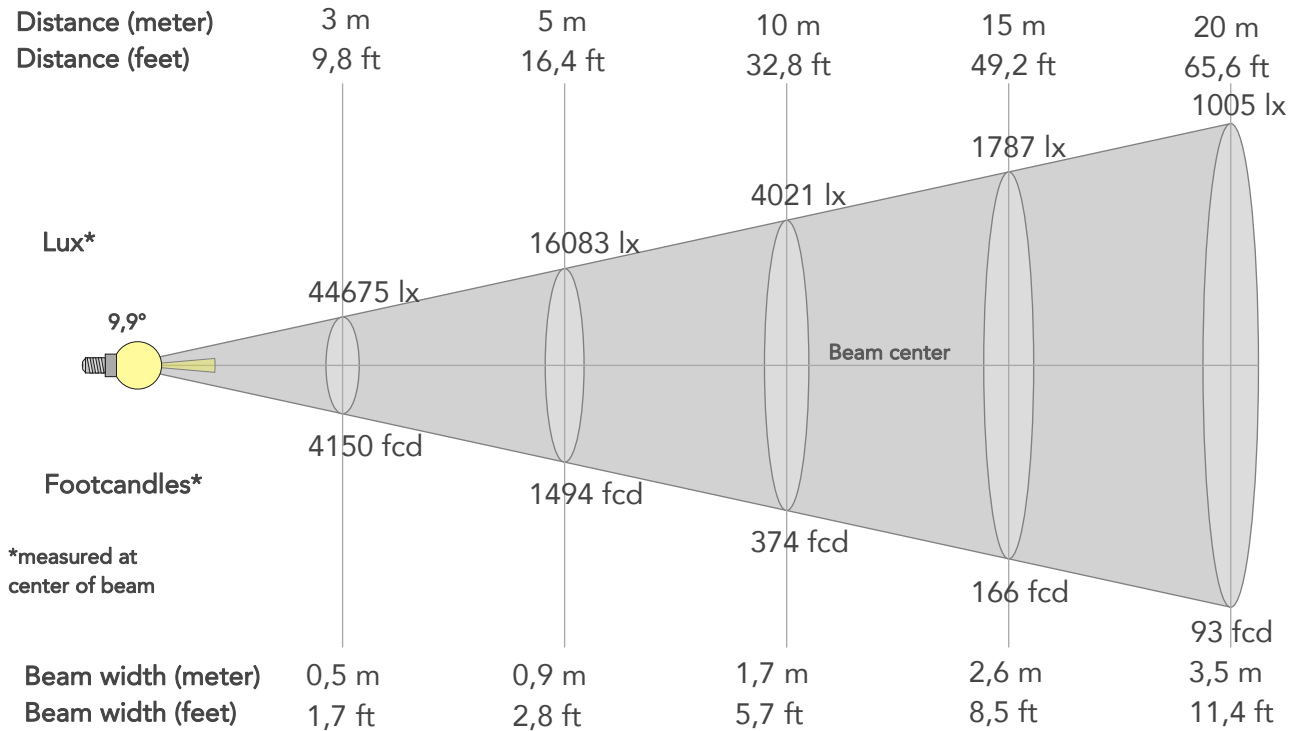

## BEAM INTENSITIES AND WIDTHS

Distance	1m	2m	3m	4m	5m	7,5m	10m	15m	20m	25m	30m	40m	50m
Distance	3,3ft	6,6ft	9,8ft	13,1ft	16,4ft	24,6ft	32,8ft	49,2ft	65,6ft	82ft	98,4ft	131,2ft	164ft
Lux	402077lx	100519lx	44675lx	25130lx	16083lx	7148lx	4021lx	1787lx	1005lx	643lx	447lx	251lx	161lx
Footcand.	37354fcd	9339fcd	4150fcd	2335fcd	1494fcd	664fcd	374fcd	166fcd	93fcd	60fcd	42fcd	23fcd	15fcd
Beam wid.	0,2m	0,3m	0,5m	0,7m	0,9m	1,3m	1,7m	2,6m	3,5m	4,3m	5,2m	6,9m	8,7m
Beam wid.	0,6ft	1,1ft	1,7ft	2,3ft	2,8ft	4,3ft	5,7ft	8,5ft	11,4ft	14,2ft	17ft	22,7ft	28,4ft

## LINEAR DISTRIBUTION DIAGRAM

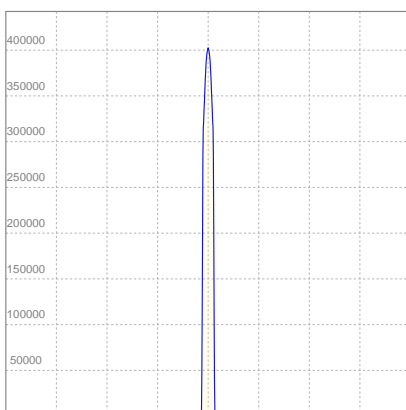

## ELECTRICAL SPECIFICATIONS

Input voltage	Input current	Input power	Effeciency
224V	1,23A	264,1W	33lm/W
Power Fc			
0,97			

## ISO CANDELA DIAGRAM

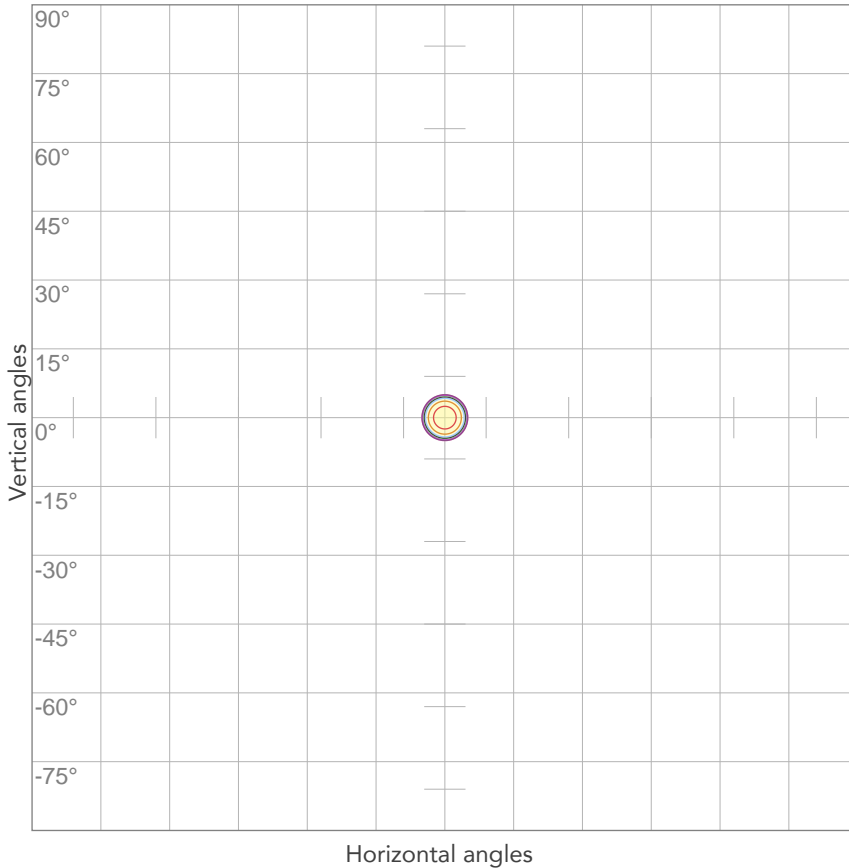

10%	40208 cd
20%	80415 cd
30%	120623 cd
40%	160831 cd
50%	201038 cd
60%	241246 cd
70%	281454 cd
80%	321661 cd

Conditions:

Number of c-planes: 2

Candela at center: 402077 cd

## ISO LUX DIAGRAM

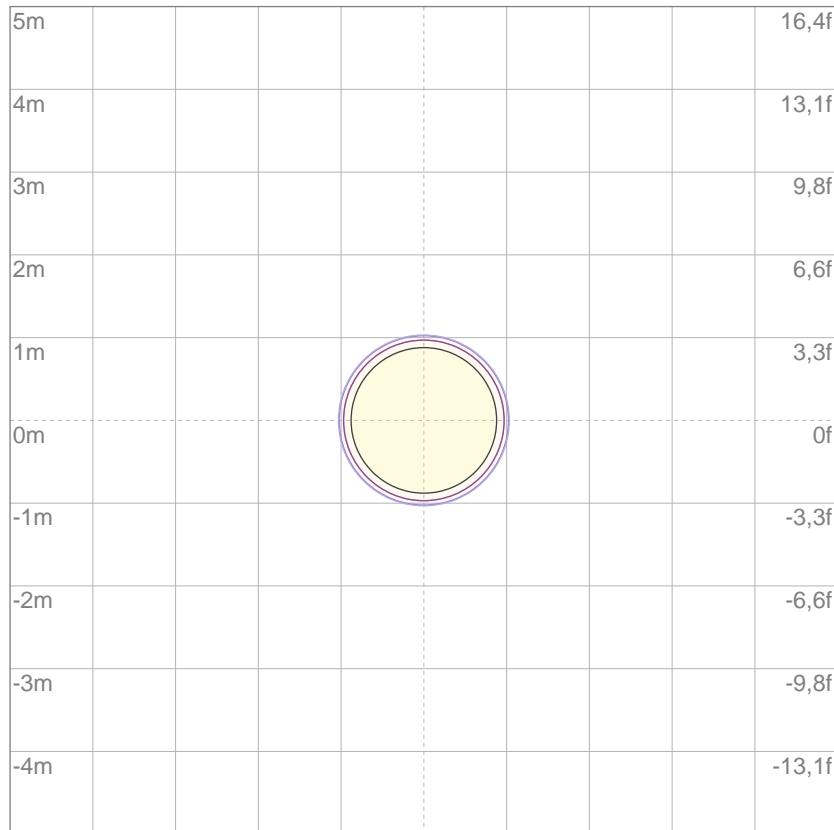

3%	121 lx
5%	201 lx
10%	402 lx
30%	1206 lx
50%	2010 lx

Conditions:

Number of c-planes: 2

Lux at center: 4021 lx

*Lux distribution on a surface when lamp is mounted at 10 meters from the surface.*

Mounting height: 10 meters (33 feet)



Total lumen output:

8061 lm

Peak candela output:

197358 cd

Light quality:

CRI: 97,0

Color temperature:

5469 K

PRODUCT NAME:

ECLFWDY

MEASURAMENT CONDITIONS:

Beam angle:

PRL14

Target:

Cold White

Operator:

Paolo Carvone

Date and time:

17/11/2020 14:19:29

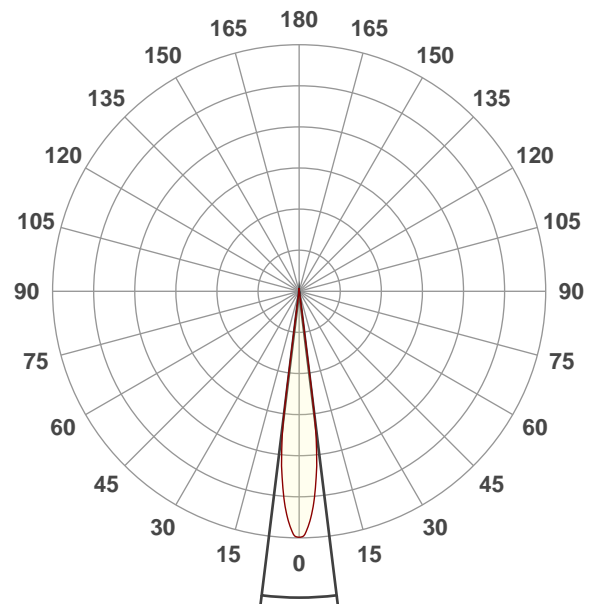

Spectra

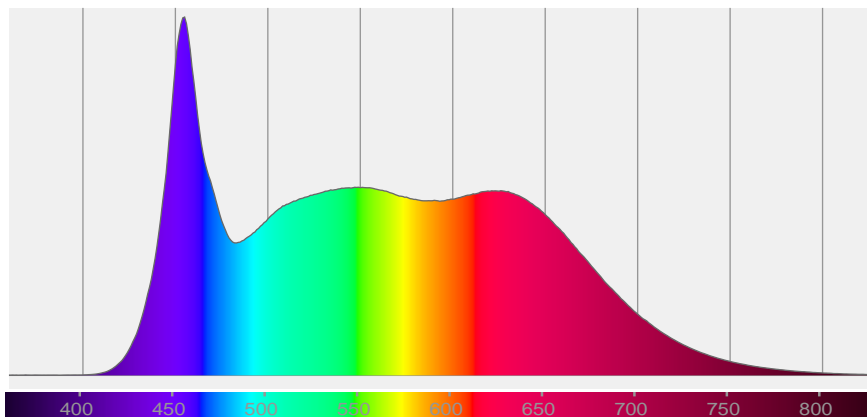

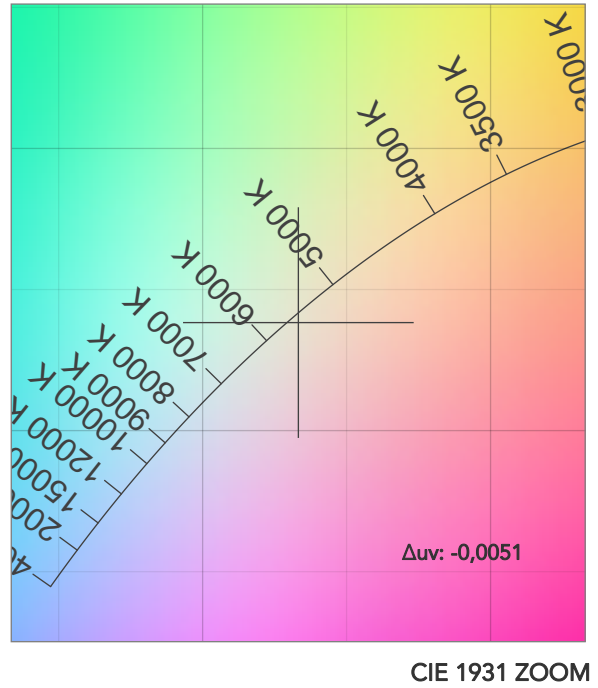
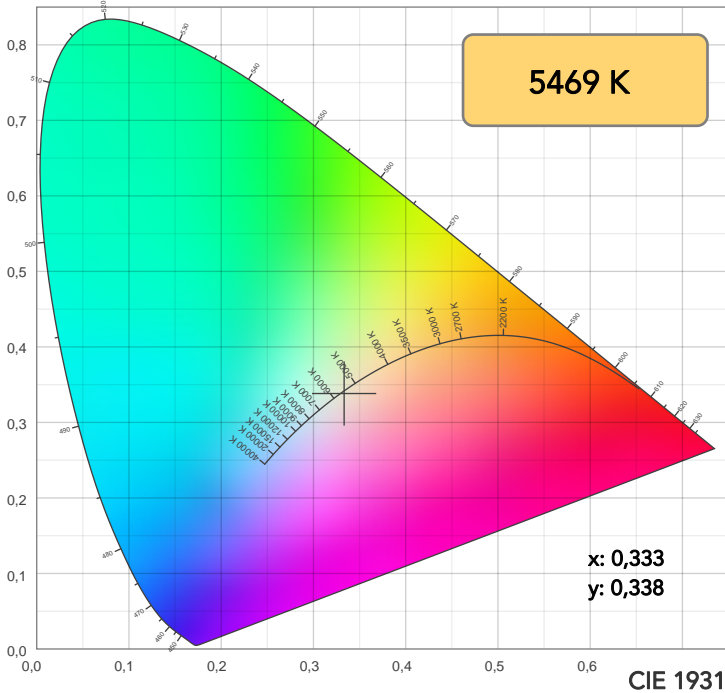

TM30: 90,5

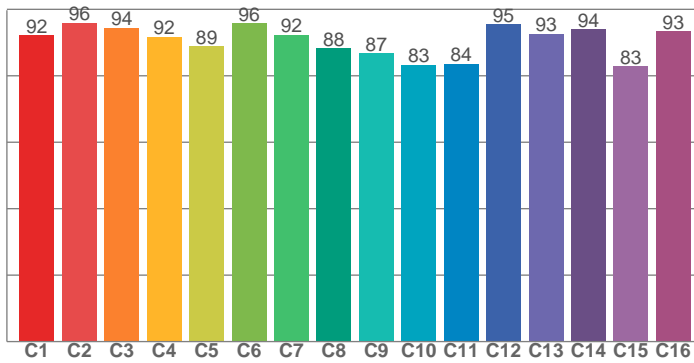

CRI: 97,0 (R1-R8)

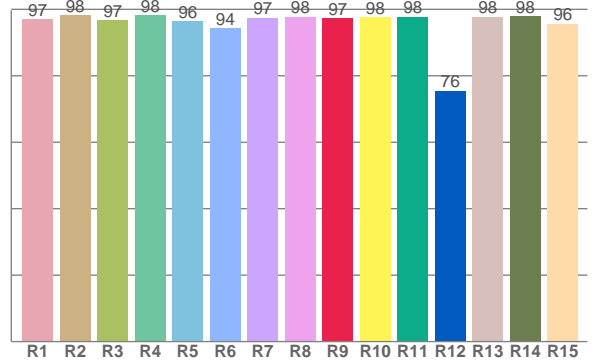

CRI R values, only R1-R8 are used to calculate final CRI value

R1	R2	R3	R4	R5	R6	R7	R8	R9	R10	R11	R12	R13	R14	R15
97,0	98,2	96,7	98,1	96,3	94,2	97,4	97,8	97,3	97,5	97,8	75,5	97,8	97,8	95,6

TM30 C values, 16 binned values out of total of 99 C values

C1	C2	C3	C4	C5	C6	C7	C8	C9	C10	C11	C12	C13	C14	C15	C16
92,1	95,9	94,5	91,8	88,8	95,8	92,4	88,2	86,7	83,3	83,6	95,5	92,6	93,9	82,8	93,4

CQS Q values

Q1	Q2	Q3	Q4	Q5	Q6	Q7	Q8	Q9	Q10	Q11	Q12	Q13	Q14	Q15
94,7	99,5	87,7	86,1	91,1	95,0	97,4	98,4	97,1	96,0	94,8	95,3	96,1	97,4	96,7

CQS: 93,7

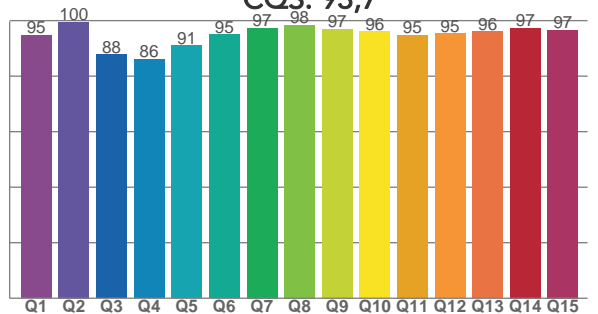

COLOR PARAMETERS

Color temperature	Color rendering index	Red component	Color fidelity	Color gamut	Color quality scale	Television lighting index	Color coordinate cie 1931	Color coordinate cie 1931	Color deviation from black body
CCT	CRI	CRI R9	TM30 Rf	TM30 Rg	CQS	TLCI	x	y	Δuv
5469 K	97,0	97,3	90,5	99,5	93,7	97	0,333	0,338	-0,0051

# TM30 DETAILS

**Rf 90,5**  
Fidelity index Rf

**Rg 99,5**  
Gammut index

Hue Bin	R <sub>f</sub>	Graphic shifts (%)	
		Chroma	Hue
1	92	-1%	1%
2	96	0%	1%
3	94	0%	0%
4	92	-3%	-1%
5	89	-5%	-1%
6	96	-2%	0%
7	92	-4%	2%
8	88	-3%	6%
9	87	-2%	11%
10	83	1%	9%
11	84	4%	8%
12	95	3%	1%
13	93	4%	-2%
14	94	1%	-1%
15	83	8%	-9%
16	93	0%	-1%

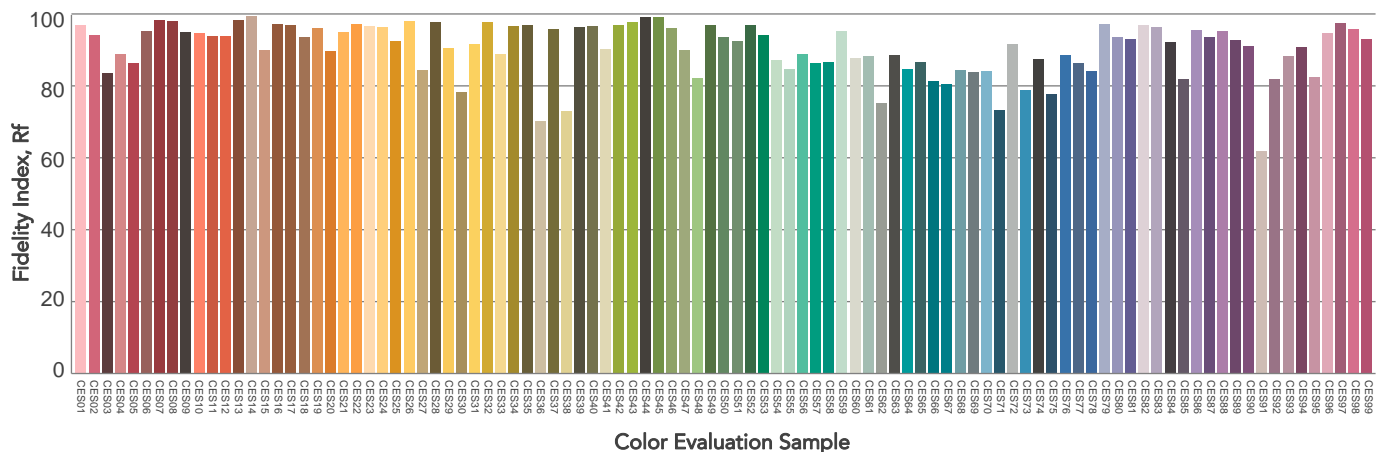
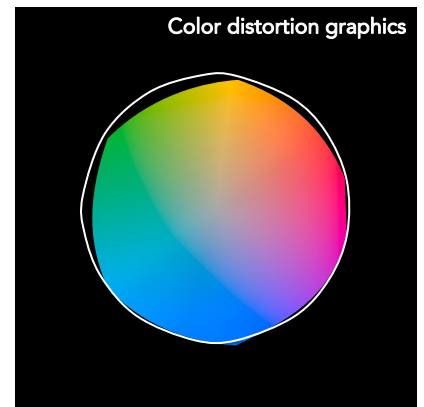
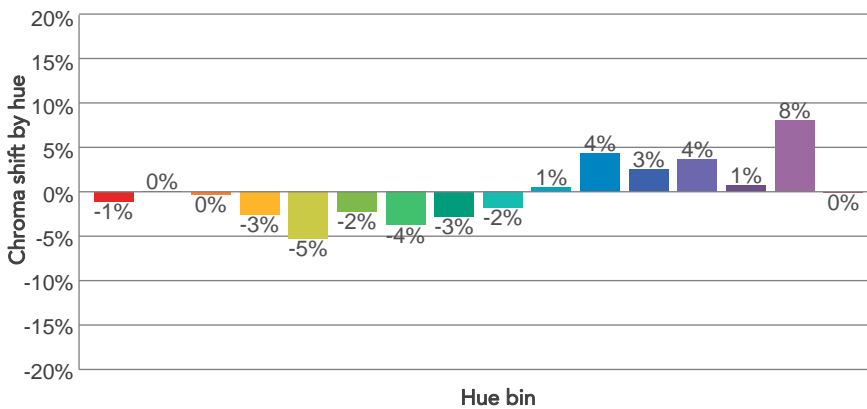
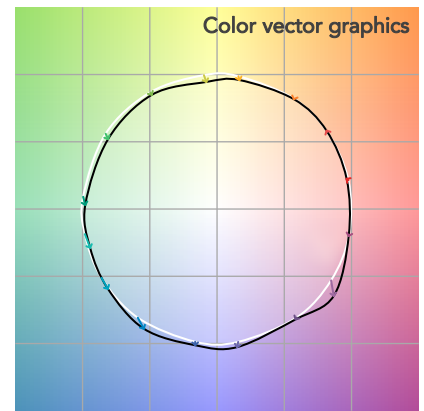
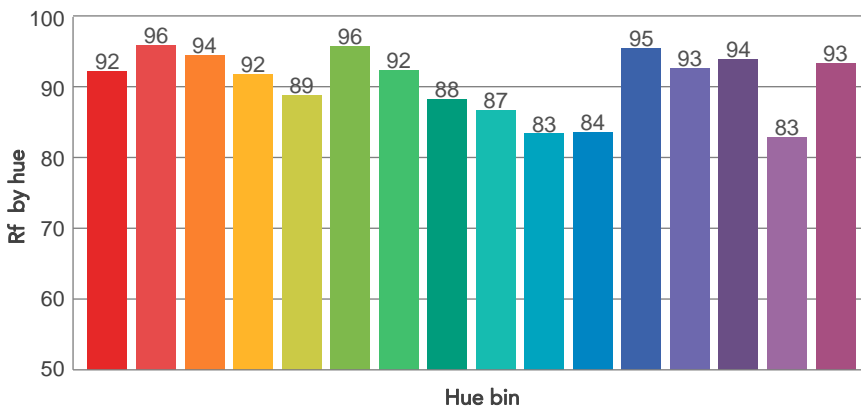
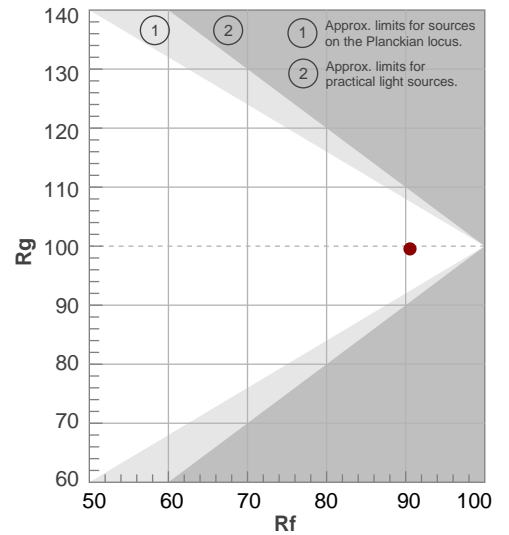



Beam angle 50%	Field angle 10%	Cut off angle 2,5%	Intensity ratio in 120° cone	Intensity ratio in 90° cone
14,1°	15,8°	17,1°	100,0%	100,0%

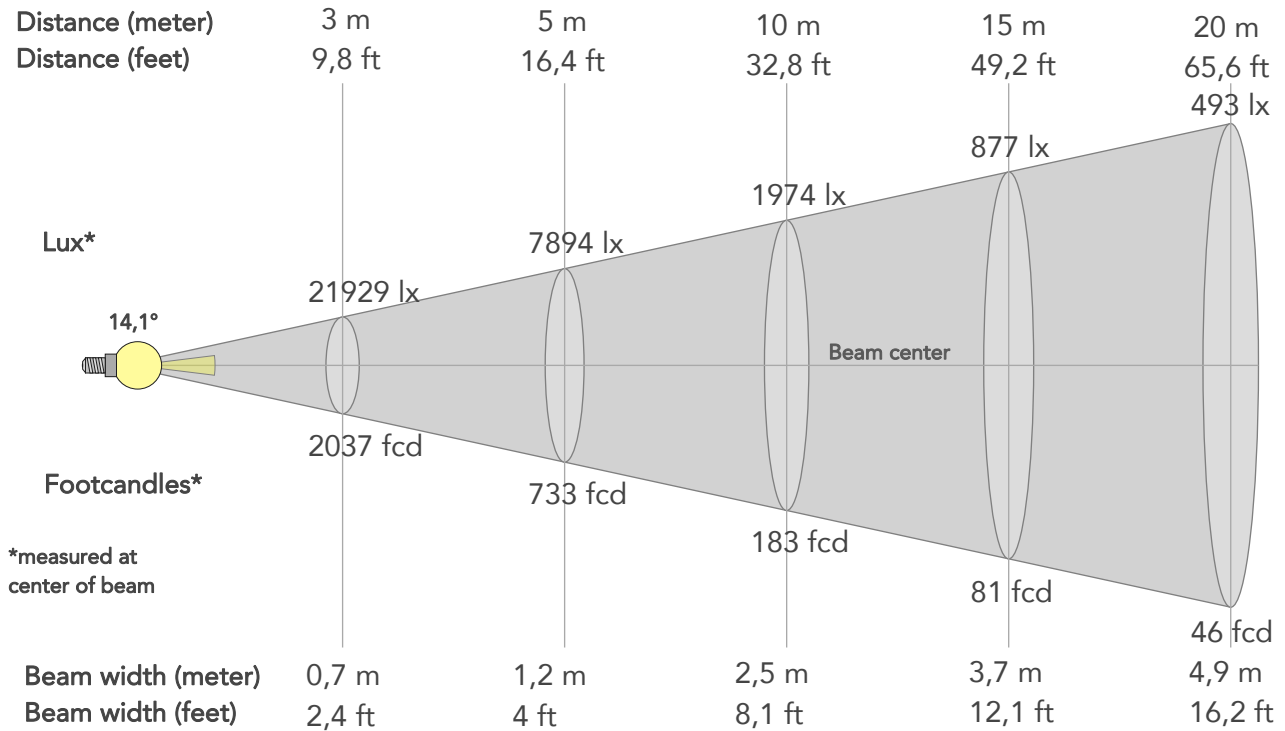

## BEAM INTENSITIES AND WIDTHS

Distance	1m	2m	3m	4m	5m	7,5m	10m	15m	20m	25m	30m	40m	50m
Distance	3,3ft	6,6ft	9,8ft	13,1ft	16,4ft	24,6ft	32,8ft	49,2ft	65,6ft	82ft	98,4ft	131,2ft	164ft
Lux	197358lx	49340lx	21929lx	12335lx	7894lx	3509lx	1974lx	877lx	493lx	316lx	219lx	123lx	79lx
Footcand.	18335fcd	4584fcd	2037fcd	1146fcd	733fcd	326fcd	183fcd	81fcd	46fcd	29fcd	20fcd	11fcd	7fcd
Beam wid.	0,2m	0,5m	0,7m	1m	1,2m	1,8m	2,5m	3,7m	4,9m	6,2m	7,4m	9,9m	12,3m
Beam wid.	0,8ft	1,6ft	2,4ft	3,2ft	4ft	6,1ft	8,1ft	12,1ft	16,2ft	20,2ft	24,3ft	32,4ft	40,4ft

## LINEAR DISTRIBUTION DIAGRAM

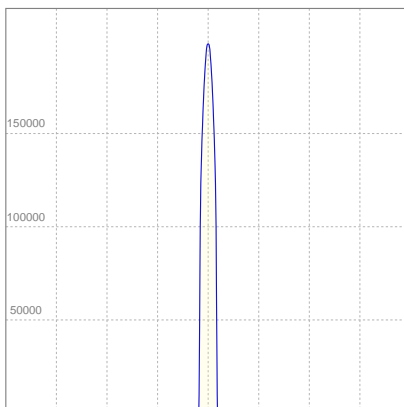

## ELECTRICAL SPECIFICATIONS

Input voltage	Input current	Input power	Effeciency
223V	1,22A	263,6W	31lm/W
Power Fc			
0,97			

## ISO CANDELA DIAGRAM

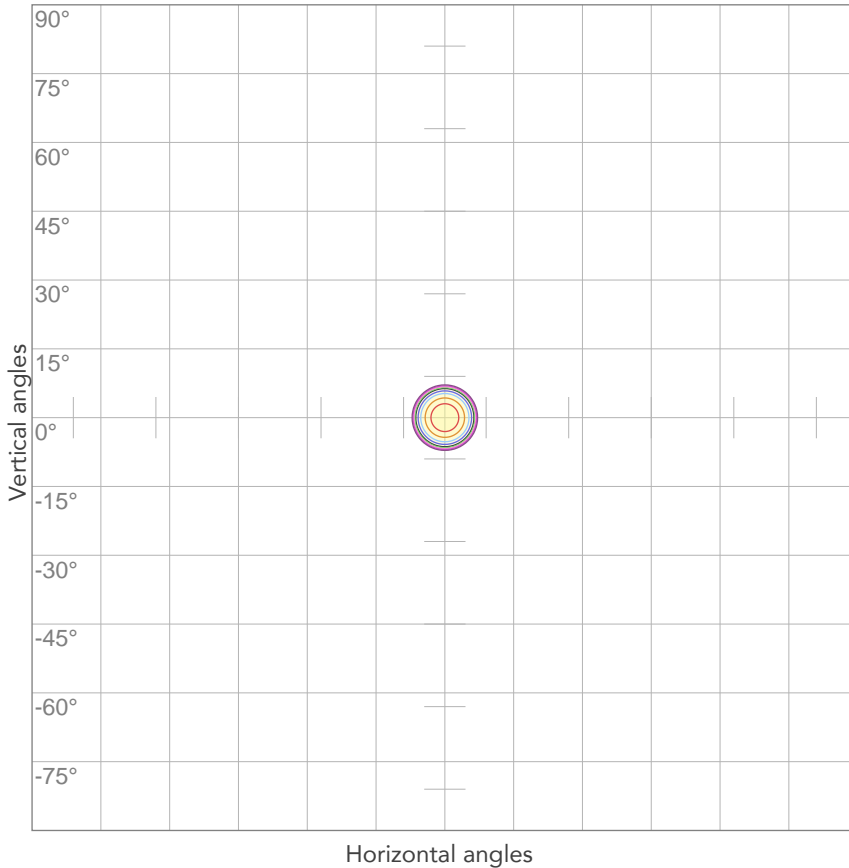

10%	19736 cd
20%	39472 cd
30%	59208 cd
40%	78943 cd
50%	98679 cd
60%	118415 cd
70%	138151 cd
80%	157887 cd

**Conditions:**

Number of c-planes: 2

Candela at center: 197358 cd

## ISO LUX DIAGRAM

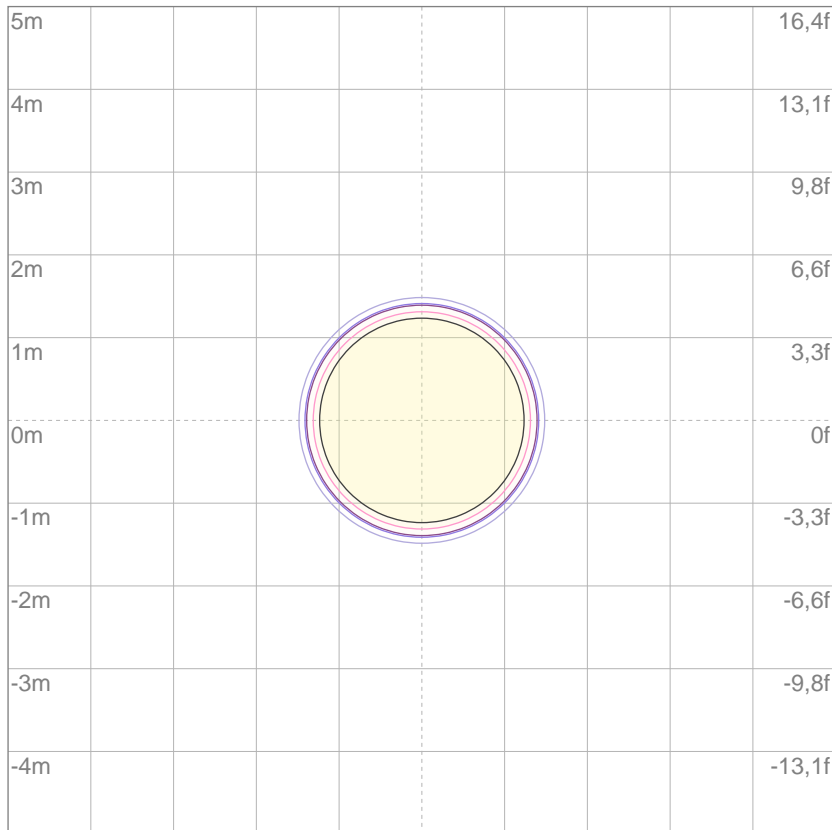

3%	59,2 lx
5%	98,7 lx
10%	197 lx
30%	592 lx
50%	987 lx

**Conditions:**

Number of c-planes: 2

Lux at center: 1974 lx

*Lux distribution on a surface when lamp is mounted at 10 meters from the surface.*

Mounting height: 10 meters (33 feet)



Total lumen output:

8704 lm

Peak candela output:

115650 cd

Light quality:

CRI: 97,0

Color temperature:

5515 K

PRODUCT NAME:

ECLFWDY

MEASURAMENT CONDITIONS:

Beam angle:

PRL19

Target:

Cold White

Operator:

Paolo Carvone

Date and time:

17/11/2020 14:21:51

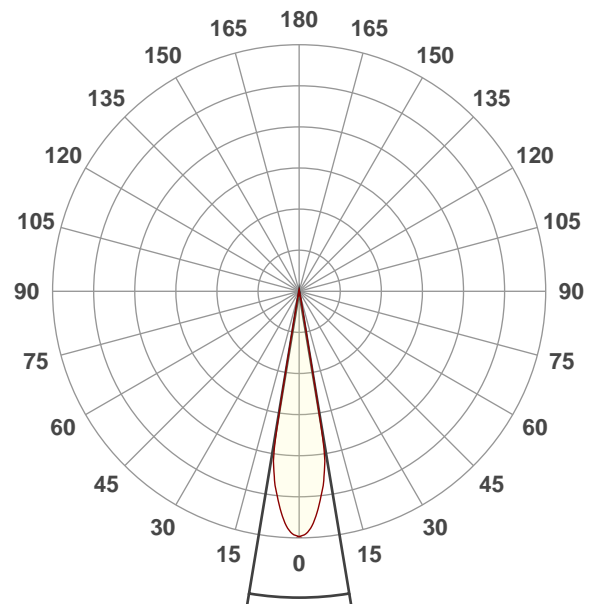

Spectra

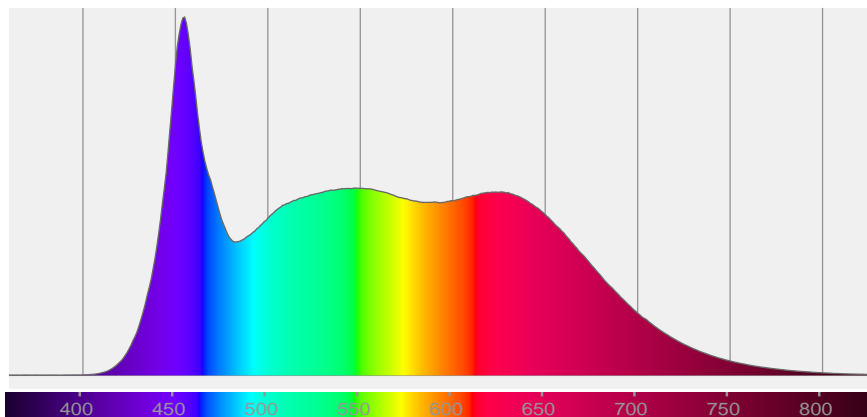

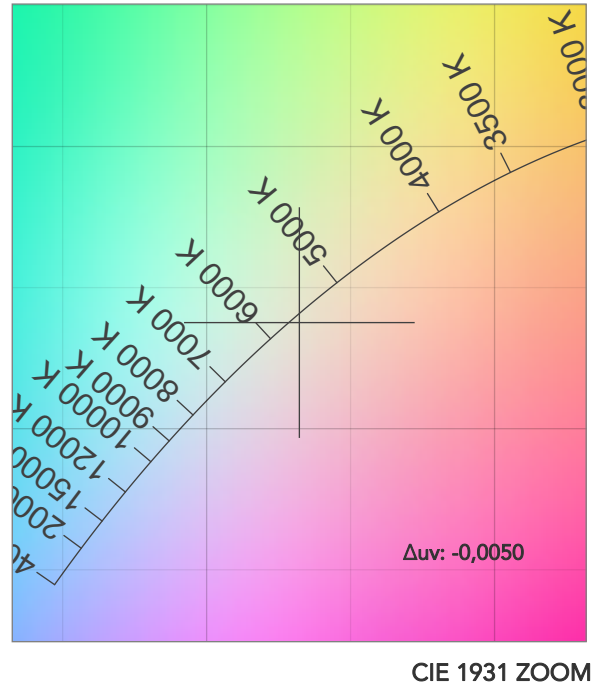
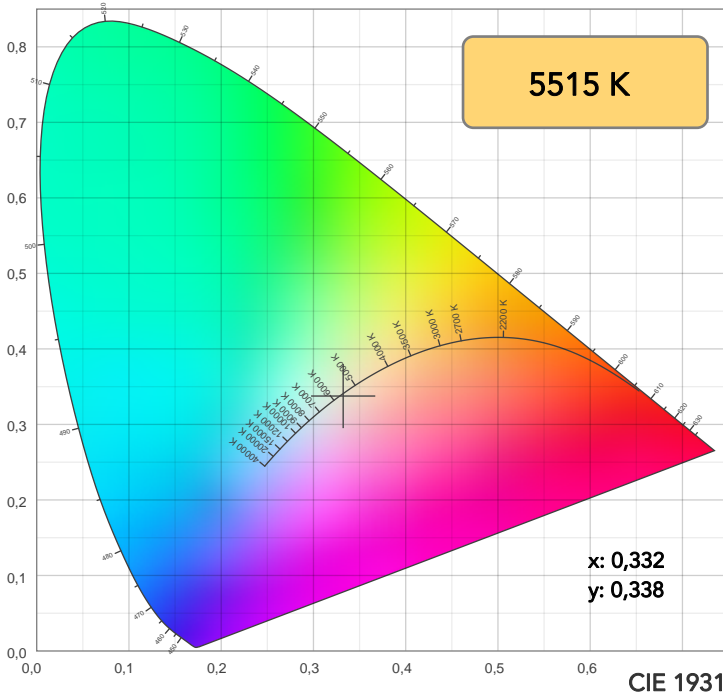

TM30: 91,4

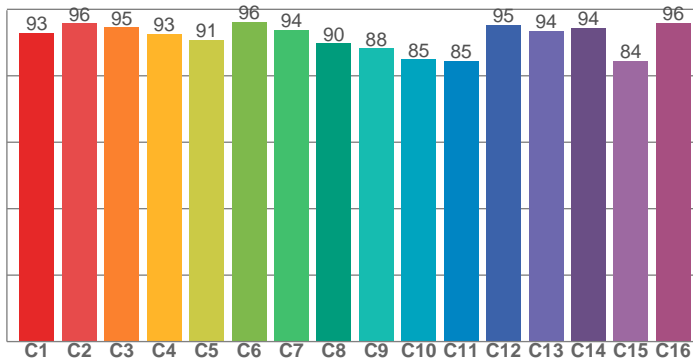

CRI: 97,0 (R1-R8)

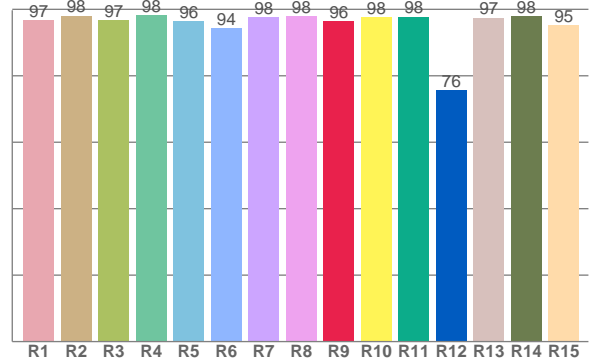

CRI R values, only R1-R8 are used to calculate final CRI value

R1	R2	R3	R4	R5	R6	R7	R8	R9	R10	R11	R12	R13	R14	R15
96,8	98,1	96,8	98,3	96,3	94,4	97,6	97,8	96,4	97,7	97,8	75,7	97,5	97,9	95,3

TM30 C values, 16 binned values out of total of 99 C values

C1	C2	C3	C4	C5	C6	C7	C8	C9	C10	C11	C12	C13	C14	C15	C16
92,8	95,7	94,6	92,6	90,8	96,2	93,8	89,8	88,2	84,9	84,5	95,4	93,5	94,4	84,4	96,0

CQS Q values

Q1	Q2	Q3	Q4	Q5	Q6	Q7	Q8	Q9	Q10	Q11	Q12	Q13	Q14	Q15
94,7	99,5	88,1	86,5	91,4	95,3	97,6	98,6	97,1	96,3	95,3	95,8	96,5	97,5	96,8

CQS: 93,9

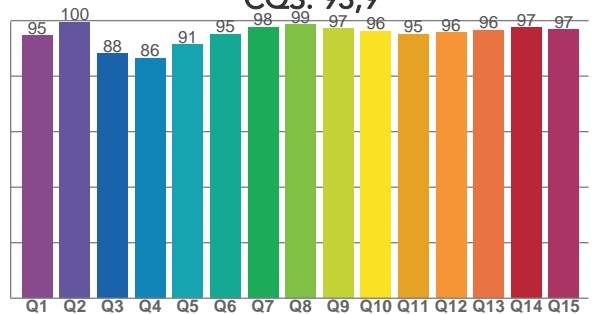

COLOR PARAMETERS

Color temperature	Color rendering index	Red component	Color fidelity	Color gamut	Color quality scale	Television lighting index	Color coordinate cie 1931	Color coordinate cie 1931	Color deviation from black body
CCT	CRI	CRI R9	TM30 Rf	TM30 Rg	CQS	TLCI	x	y	Δuv
5515 K	97,0	96,4	91,4	100,2	93,9	98	0,332	0,338	-0,0050

# TM30 DETAILS

**Rf 91,4**  
Fidelity index Rf

**Rg 100,2**  
Gammut index

Hue Bin	R <sub>f</sub>	Graphic shifts (%)	
		Chroma	Hue
1	93	-1%	1%
2	96	0%	1%
3	95	0%	0%
4	93	-2%	-1%
5	91	-4%	0%
6	96	-1%	0%
7	94	-3%	2%
8	90	-2%	5%
9	88	-1%	9%
10	85	1%	9%
11	85	4%	8%
12	95	2%	1%
13	94	4%	-1%
14	94	1%	-1%
15	84	8%	-8%
16	96	-1%	1%

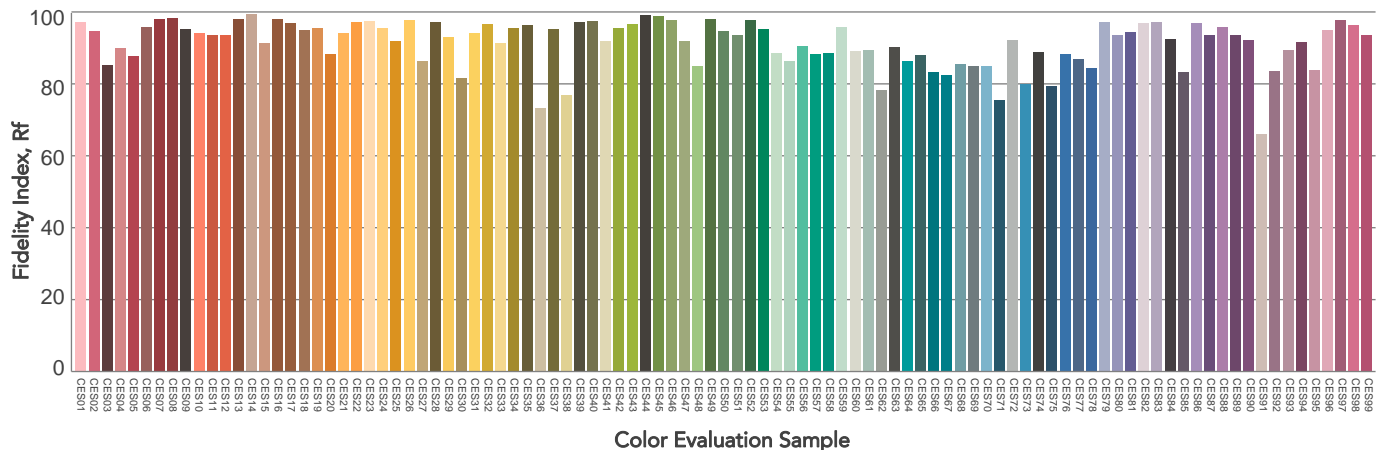
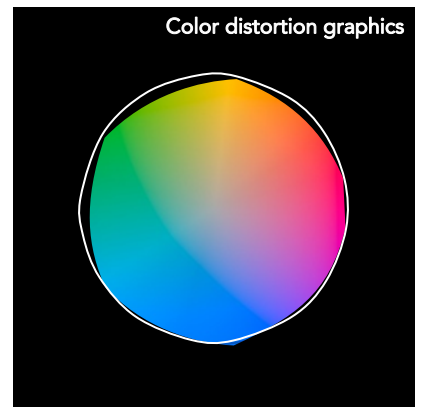
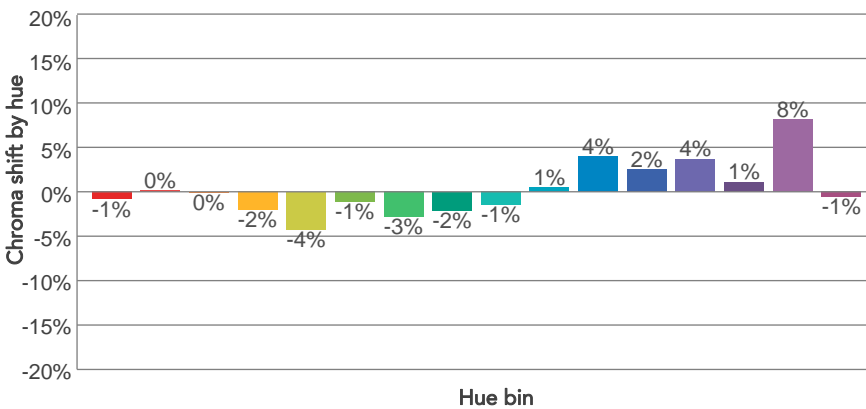
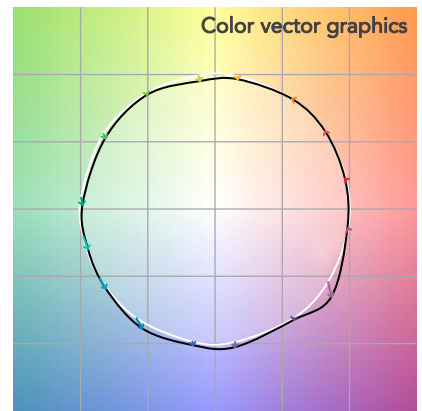
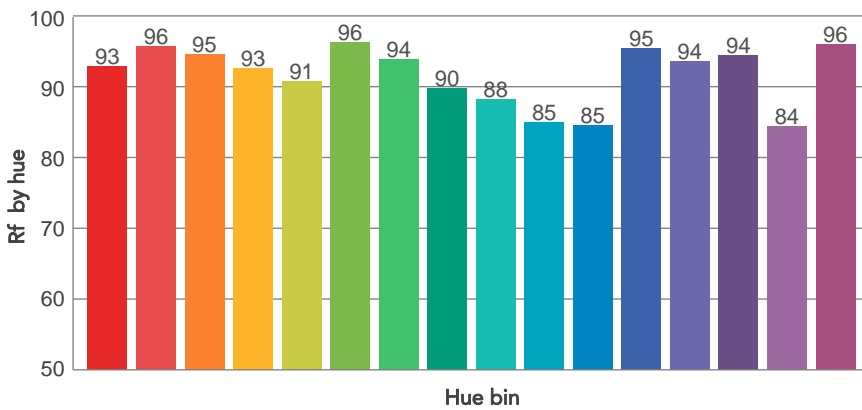
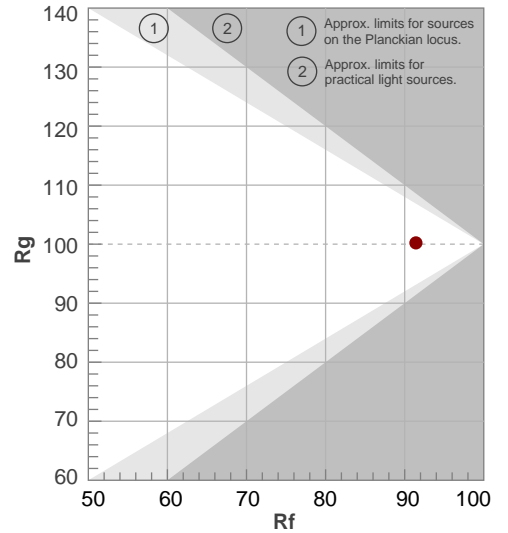

# BEAM DETAILS



Beam angle 50%	Field angle 10%	Cut off angle 2,5%	Intensity ratio in 120° cone	Intensity ratio in 90° cone
18,8°	21°	23,2°	100,0%	100,0%

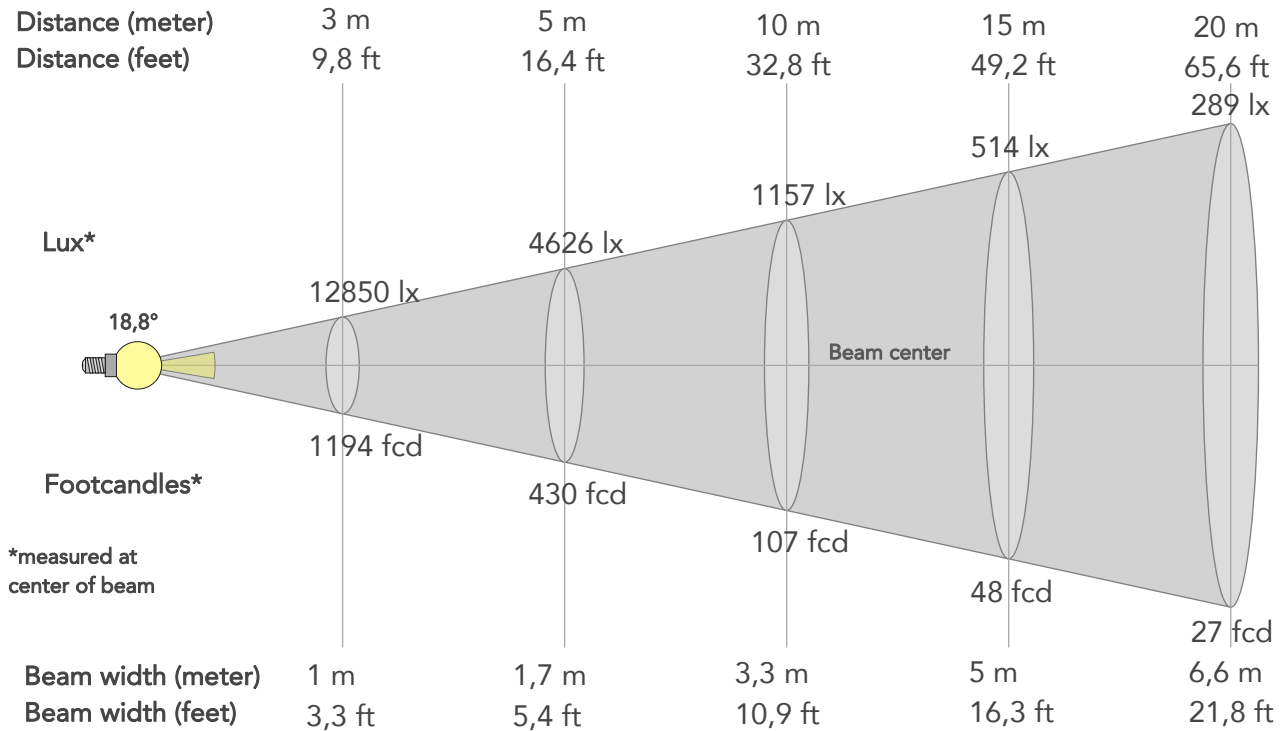

## BEAM INTENSITIES AND WIDTHS

Distance	1m	2m	3m	4m	5m	7,5m	10m	15m	20m	25m	30m	40m	50m
Distance	3,3ft	6,6ft	9,8ft	13,1ft	16,4ft	24,6ft	32,8ft	49,2ft	65,6ft	82ft	98,4ft	131,2ft	164ft
Lux	115650lx	28913lx	12850lx	7228lx	4626lx	2056lx	1157lx	514lx	289lx	185lx	129lx	72lx	46lx
Footcand.	10744fcd	2686fcd	1194fcd	672fcd	430fcd	191fcd	107fcd	48fcd	27fcd	17fcd	12fcd	7fcd	4fcd
Beam wid.	0,3m	0,7m	1m	1,3m	1,7m	2,5m	3,3m	5m	6,6m	8,3m	10m	13,3m	16,6m
Beam wid.	1,1ft	2,2ft	3,3ft	4,3ft	5,4ft	8,2ft	10,9ft	16,3ft	21,8ft	27,2ft	32,6ft	43,5ft	54,4ft

## LINEAR DISTRIBUTION DIAGRAM

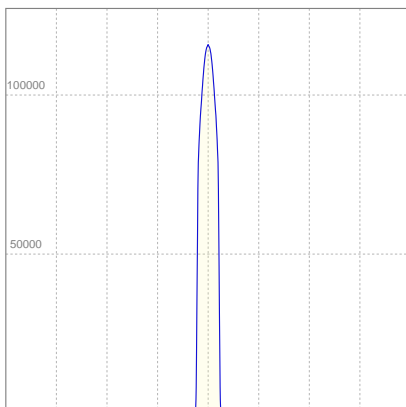

## ELECTRICAL SPECIFICATIONS

Input voltage	Input current	Input power	Effeciency
224V	1,22A	263,1W	33lm/W

Power Fc
0,97

## ISO CANDELA DIAGRAM

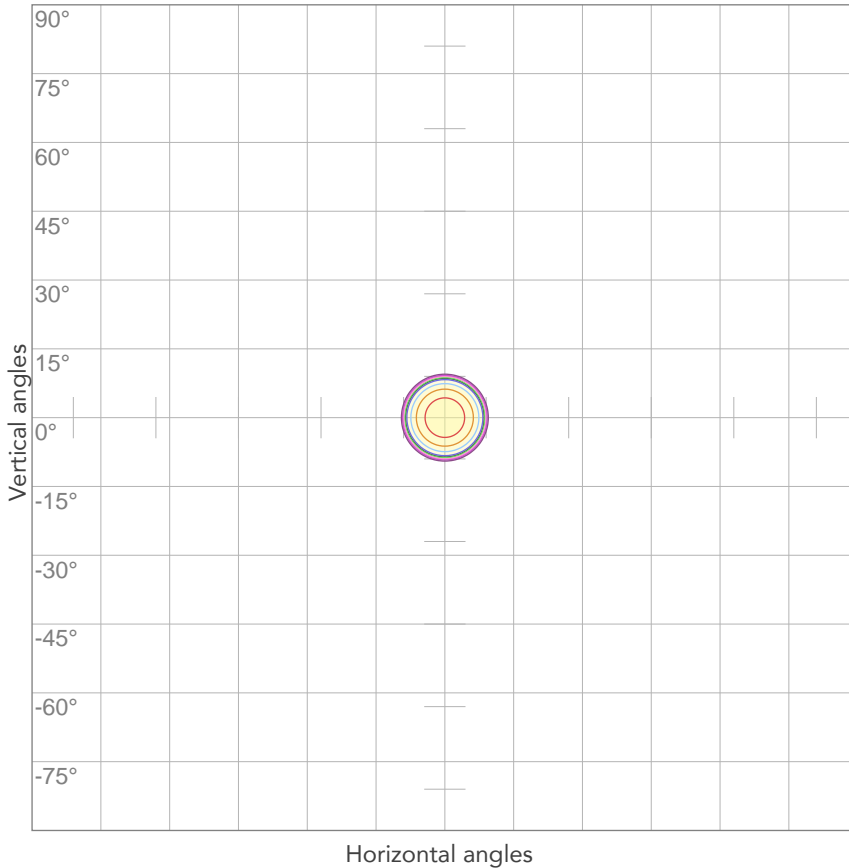

10%	11565 cd
20%	23130 cd
30%	34695 cd
40%	46260 cd
50%	57825 cd
60%	69390 cd
70%	80955 cd
80%	92520 cd

Conditions:

Number of c-planes: 2

Candela at center: 115650 cd

## ISO LUX DIAGRAM

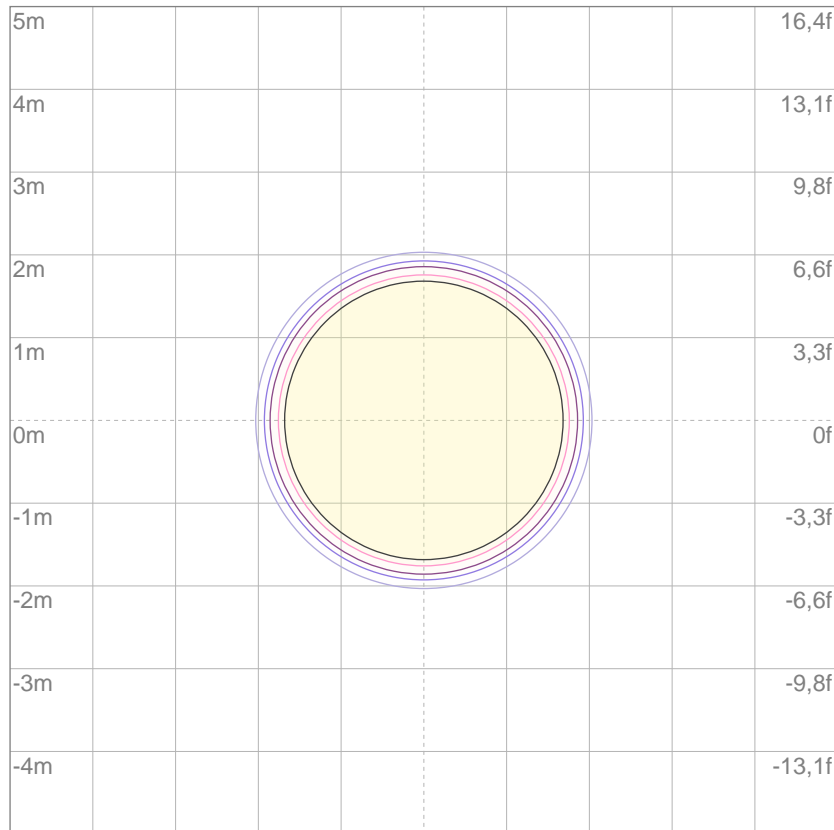

3%	34,7 lx
5%	57,8 lx
10%	116 lx
30%	347 lx
50%	578 lx

Conditions:

Number of c-planes: 2

Lux at center: 1157 lx

*Lux distribution on a surface when lamp is mounted at 10 meters from the surface.*

Mounting height: 10 meters (33 feet)



Total lumen output:

9876 lm

Peak candela output:

68054 cd

Light quality:

CRI: 97,1

Color temperature:

5525 K

**PRODUCT NAME:**

ECLFWDY

**MEASURAMENT CONDITIONS:**

Beam angle:

PRL26

Target:

Cold White

Operator:

Paolo Carvone

Date and time:

17/11/2020 14:24:17

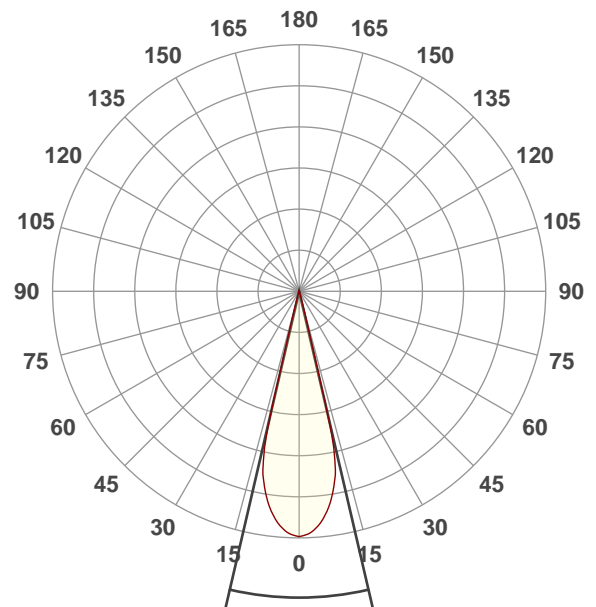

Beam angle 50%: 26,2°

Field angle 10%: 28,5°

Cut off angle 2.5%: 30,4°

Spectra

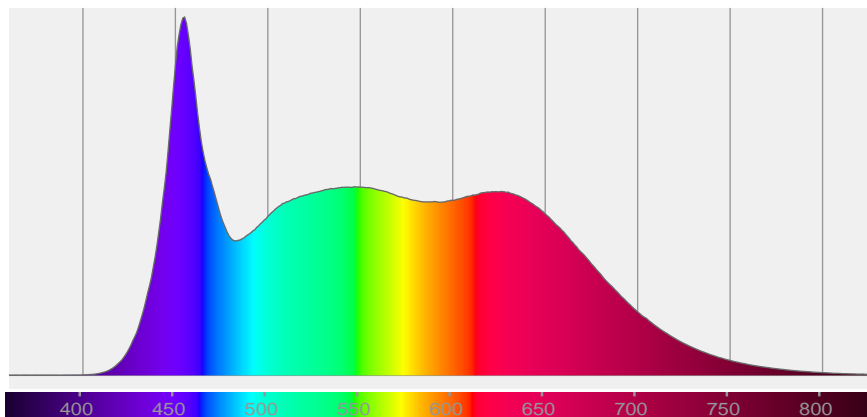



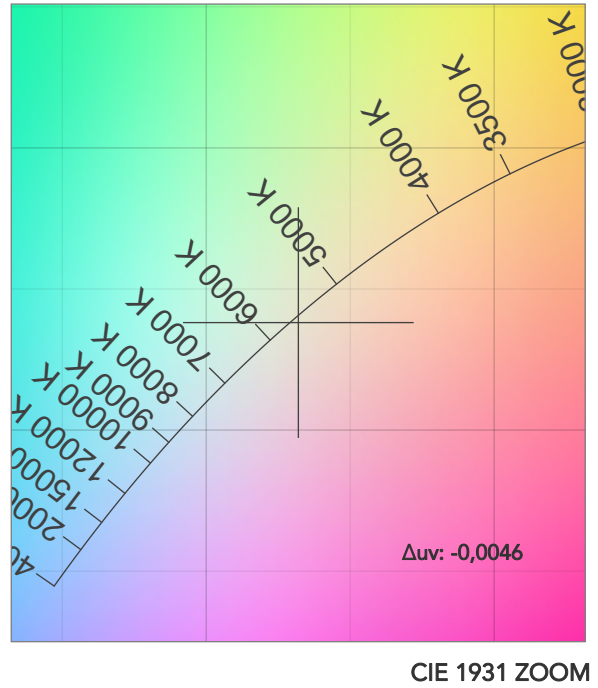
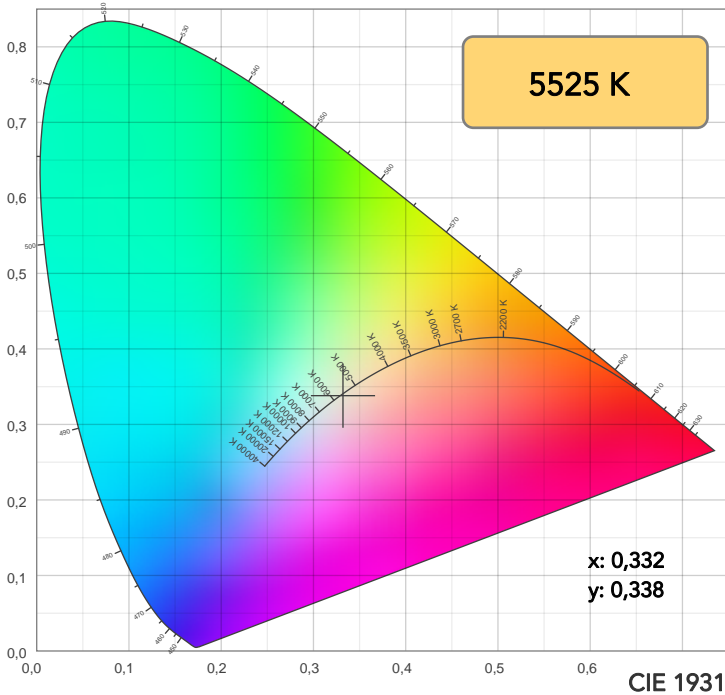

TM30: 91,5

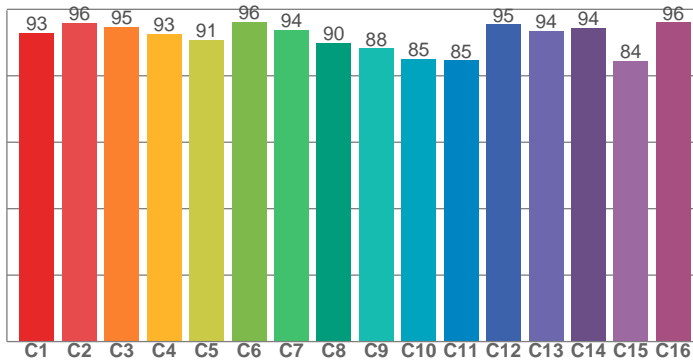

CRI: 97,1 (R1-R8)

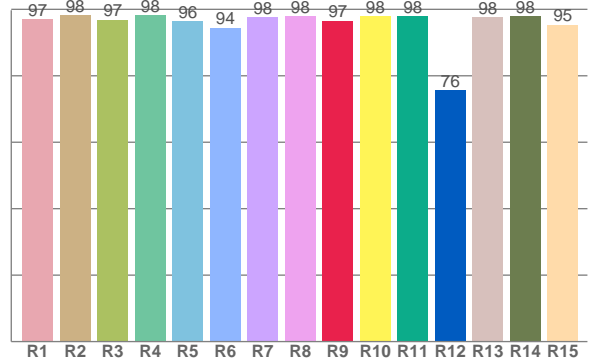

CRI R values, only R1-R8 are used to calculate final CRI value

R1	R2	R3	R4	R5	R6	R7	R8	R9	R10	R11	R12	R13	R14	R15
96,9	98,3	96,9	98,3	96,4	94,5	97,6	97,8	96,6	97,8	97,9	75,7	97,7	97,9	95,4

TM30 C values, 16 binned values out of total of 99 C values

C1	C2	C3	C4	C5	C6	C7	C8	C9	C10	C11	C12	C13	C14	C15	C16
92,9	95,9	94,7	92,7	90,8	96,2	93,8	89,8	88,3	85,1	84,7	95,5	93,6	94,4	84,5	96,0

CQS Q values

Q1	Q2	Q3	Q4	Q5	Q6	Q7	Q8	Q9	Q10	Q11	Q12	Q13	Q14	Q15
94,6	99,5	88,3	86,7	91,5	95,3	97,7	98,6	97,2	96,5	95,5	96,0	96,7	97,6	96,8

CQS: 94,1

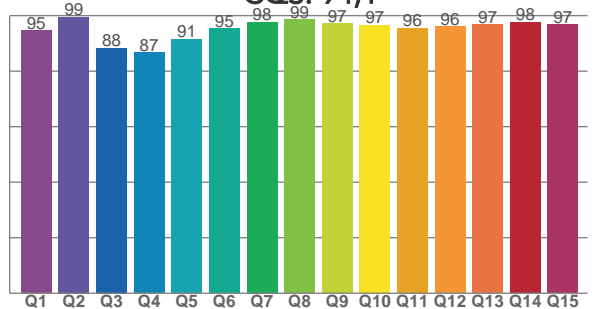

COLOR PARAMETERS

Color temperature	Color rendering index	Red component	Color fidelity	Color gamut	Color quality scale	Television lighting index	Color coordinate cie 1931	Color coordinate cie 1931	Color deviation from black body
CCT	CRI	CRI R9	TM30 Rf	TM30 Rg	CQS	TLCI	x	y	Δuv
5525 K	97,1	96,6	91,5	100,1	94,1	98	0,332	0,338	-0,0046

# TM30 DETAILS

**Rf 91,5**  
Fidelity index Rf

**Rg 100,1**  
Gammut index

Hue Bin	R <sub>f</sub>	Graphic shifts (%)	
		Chroma	Hue
1	93	-1%	1%
2	96	0%	1%
3	95	0%	0%
4	93	-2%	-1%
5	91	-4%	0%
6	96	-1%	0%
7	94	-3%	2%
8	90	-2%	5%
9	88	-1%	9%
10	85	1%	8%
11	85	4%	8%
12	95	2%	1%
13	94	4%	-1%
14	94	1%	-1%
15	84	8%	-8%
16	96	-1%	1%

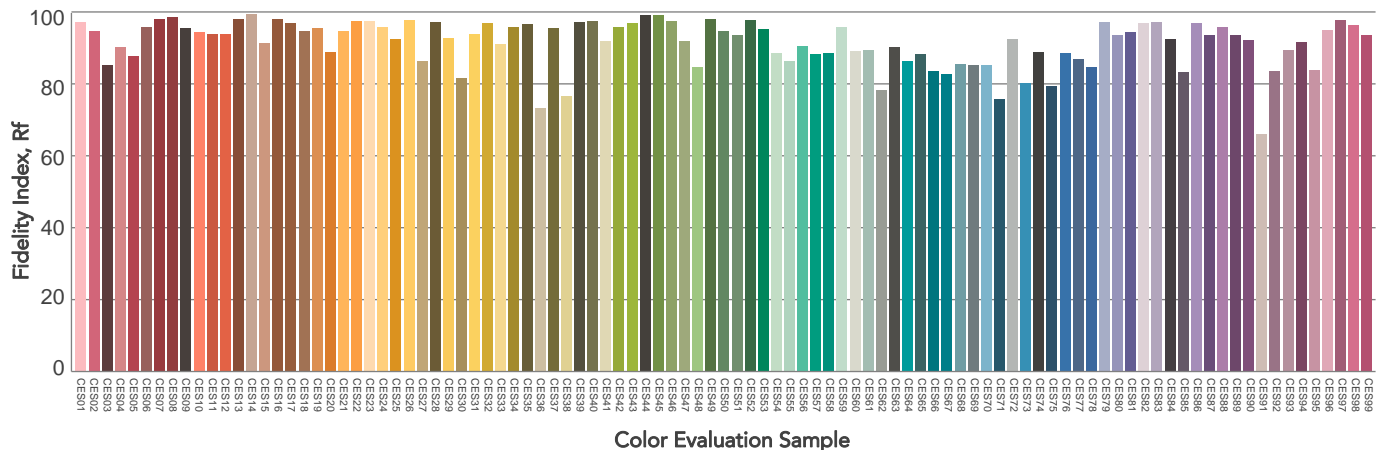
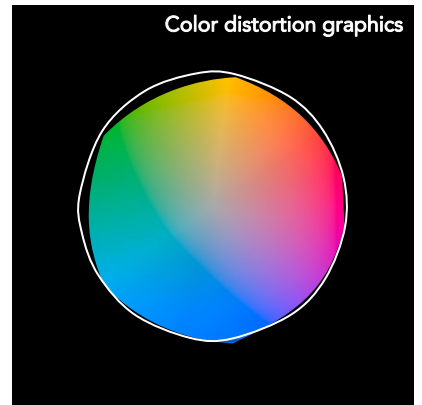
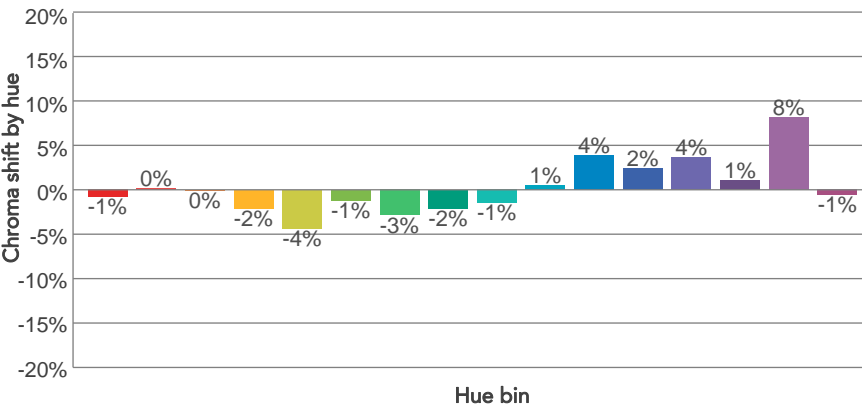
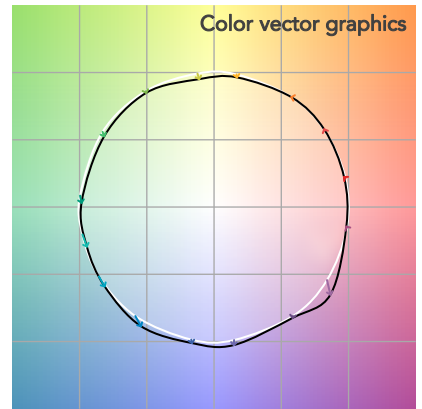
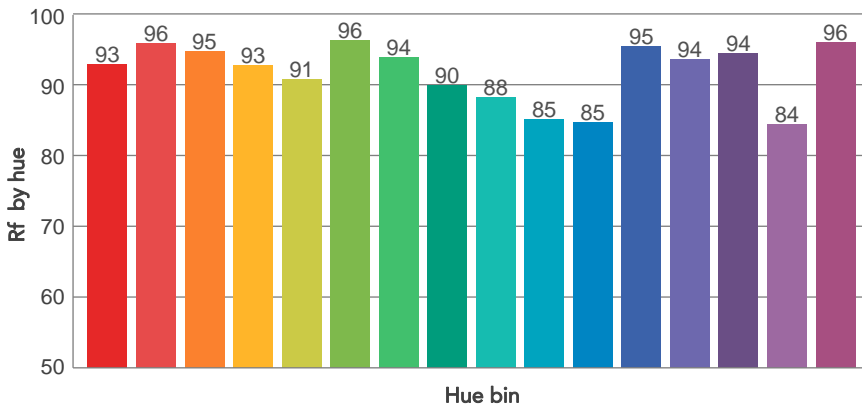
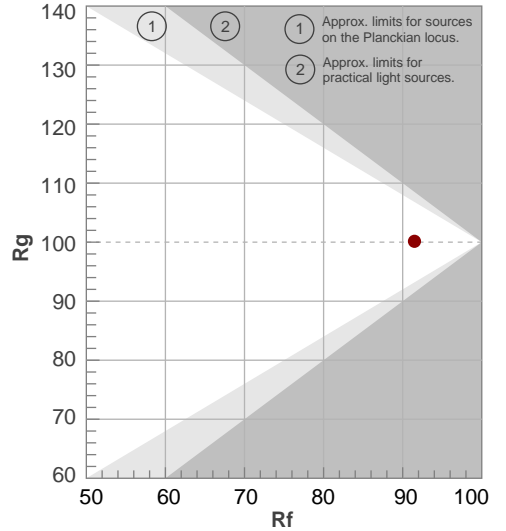

# BEAM DETAILS



Beam angle 50%	Field angle 10%	Cut off angle 2,5%	Intensity ratio in 120° cone	Intensity ratio in 90° cone
26,2°	28,5°	30,4°	100,0%	100,0%

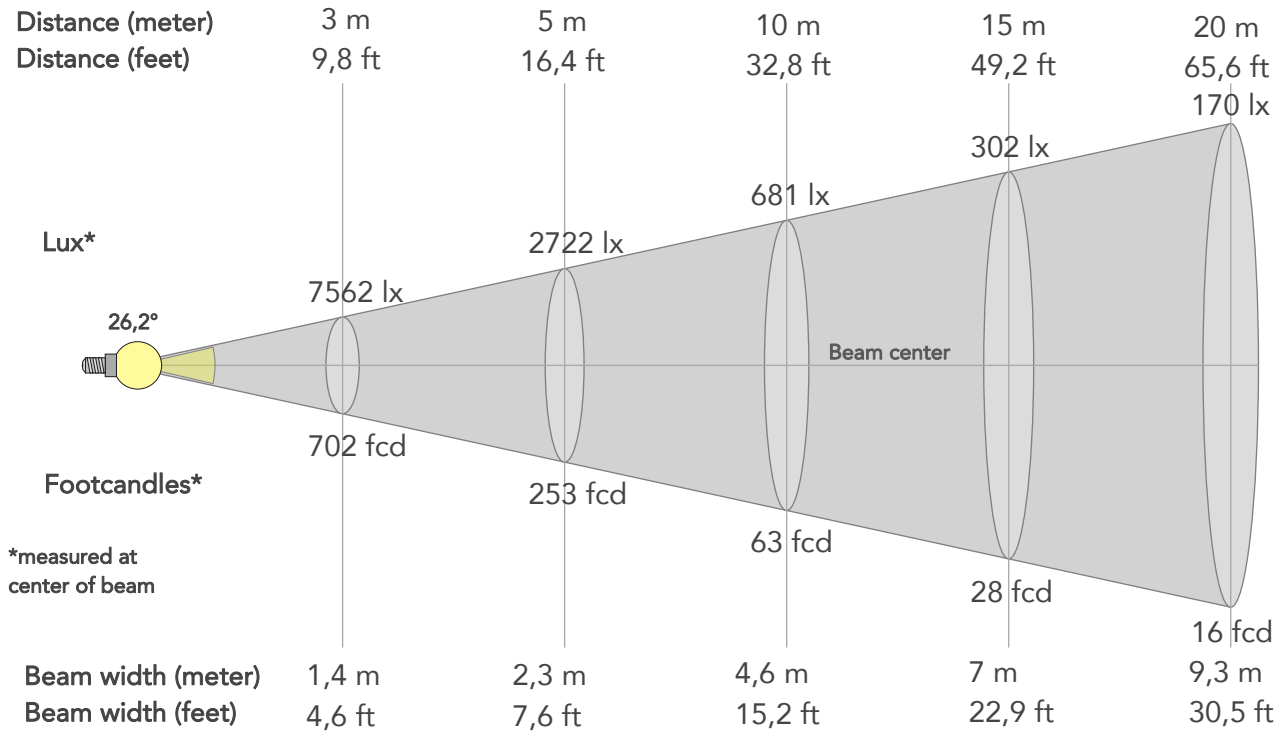

## BEAM INTENSITIES AND WIDTHS

Distance	1m	2m	3m	4m	5m	7,5m	10m	15m	20m	25m	30m	40m	50m
Distance	3,3ft	6,6ft	9,8ft	13,1ft	16,4ft	24,6ft	32,8ft	49,2ft	65,6ft	82ft	98,4ft	131,2ft	164ft
Lux	68054lx	17013lx	7562lx	4253lx	2722lx	1210lx	681lx	302lx	170lx	109lx	76lx	43lx	27lx
Footcand.	6322fcd	1581fcd	702fcd	395fcd	253fcd	112fcd	63fcd	28fcd	16fcd	10fcd	7fcd	4fcd	3fcd
Beam wid.	0,5m	0,9m	1,4m	1,9m	2,3m	3,5m	4,6m	7m	9,3m	11,6m	13,9m	18,6m	23,2m
Beam wid.	1,5ft	3,1ft	4,6ft	6,1ft	7,6ft	11,4ft	15,2ft	22,9ft	30,5ft	38,1ft	45,7ft	61ft	76,2ft

## LINEAR DISTRIBUTION DIAGRAM

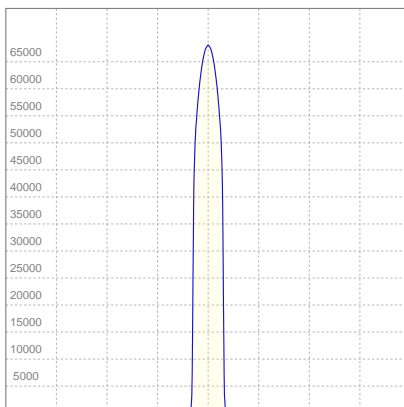

## ELECTRICAL SPECIFICATIONS

Input voltage	Input current	Input power	Effeciency
224V	1,22A	263,1W	38lm/W

Power Fc
0,97

## ISO CANDELA DIAGRAM

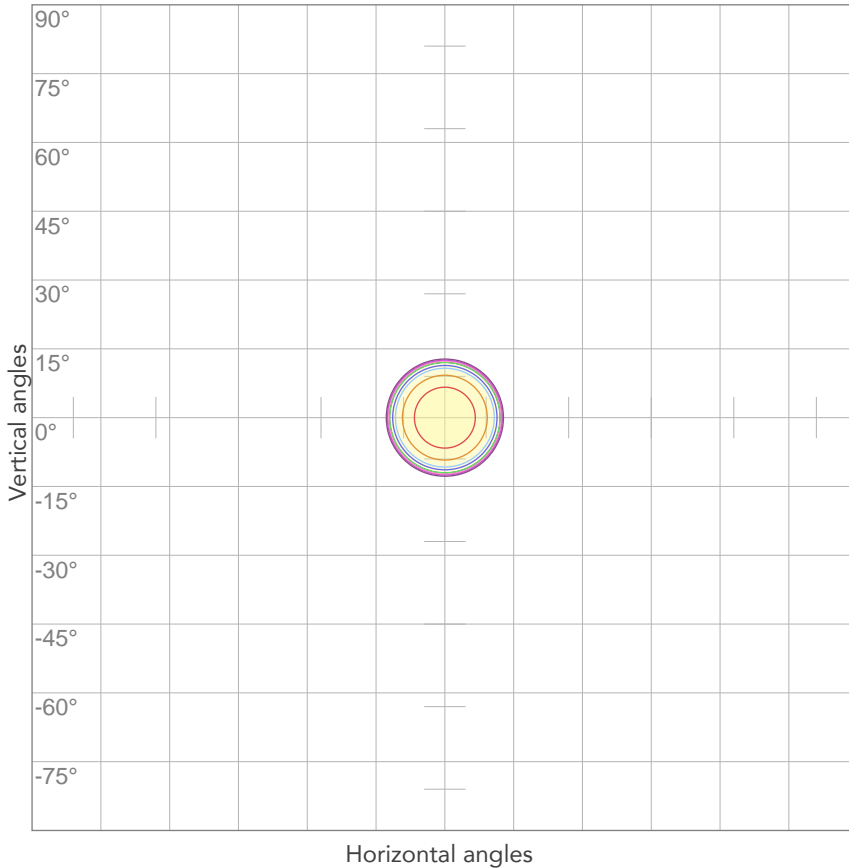

10%	6805 cd
20%	13611 cd
30%	20416 cd
40%	27222 cd
50%	34027 cd
60%	40832 cd
70%	47638 cd
80%	54443 cd

Conditions:

Number of c-planes: 2

Candela at center: 68054 cd

## ISO LUX DIAGRAM

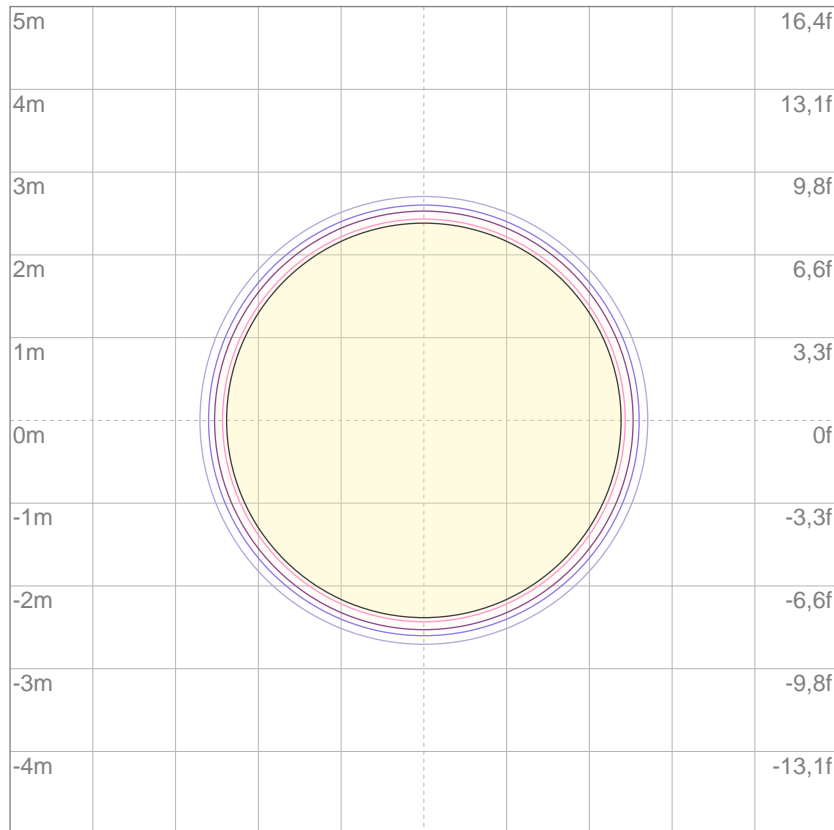

3%	20,4 lx
5%	34,0 lx
10%	68,1 lx
30%	204 lx
50%	340 lx

Conditions:

Number of c-planes: 2

Lux at center: 681 lx

*Lux distribution on a surface when lamp is mounted at 10 meters from the surface.*

Mounting height: 10 meters (33 feet)



Total lumen output:

9707 lm

Peak candela output:

36249 cd

Light quality:

CRI: 96,9

Color temperature:

5608 K

PRODUCT NAME:

ECLFWDY

MEASUREMENT CONDITIONS:

Beam angle:

PRL36

Target:

Cold White

Operator:

Paolo Carvone

Date and time:

17/11/2020 14:26:04

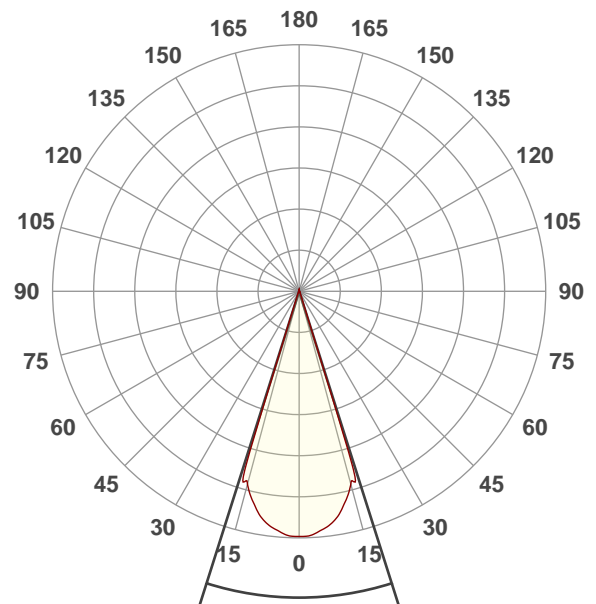

Beam angle 50%: 35,2°

Field angle 10%: 37,2°

Cut off angle 2.5%: 39,7°

Spectra

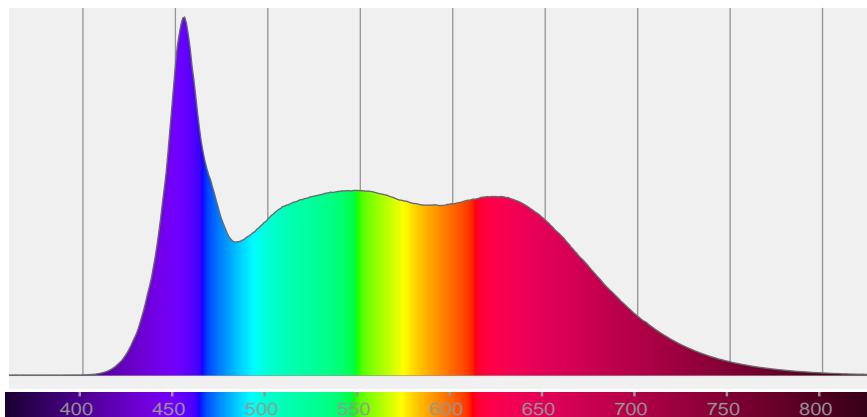

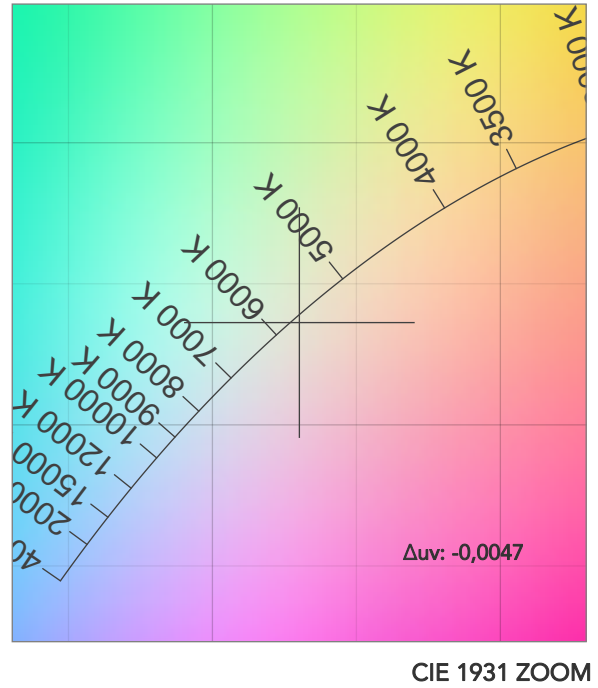
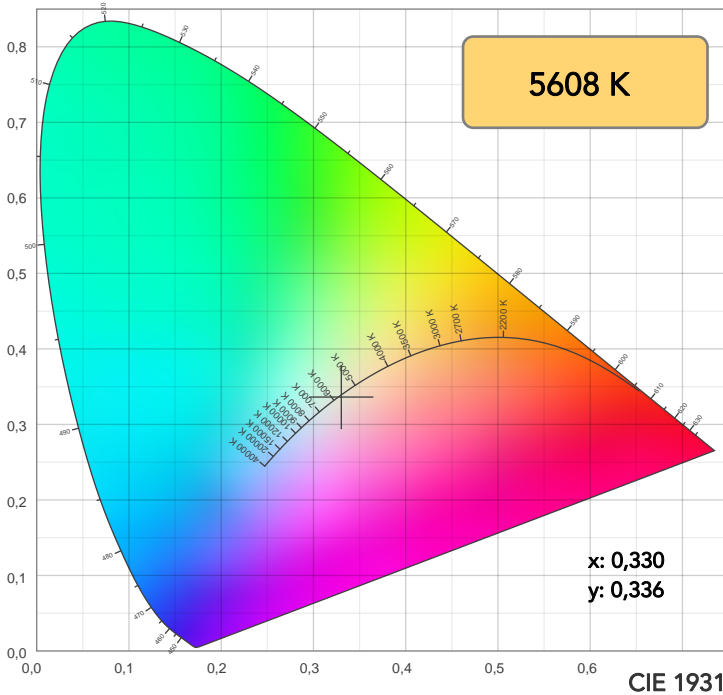

TM30: 91,2

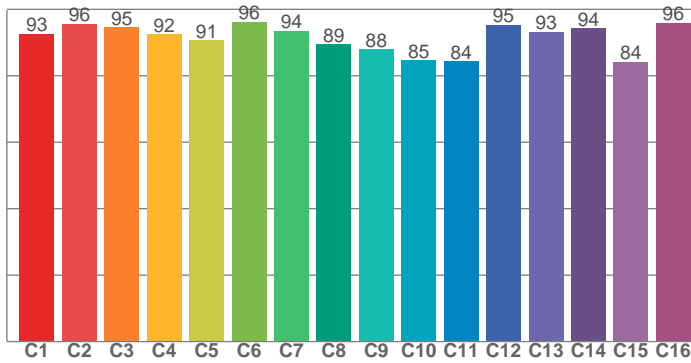

CRI: 96,9 (R1-R8)

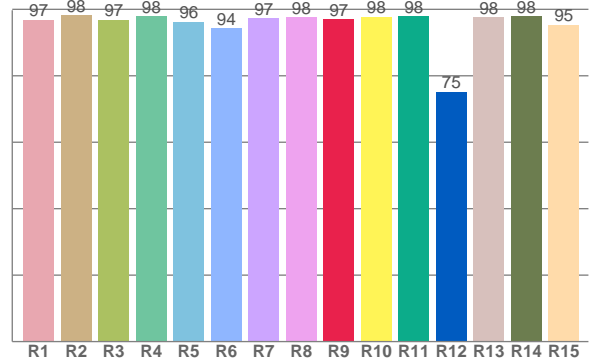

CRI R values, only R1-R8 are used to calculate final CRI value

R1	R2	R3	R4	R5	R6	R7	R8	R9	R10	R11	R12	R13	R14	R15
96,9	98,2	96,9	98,0	96,2	94,3	97,3	97,6	97,0	97,7	97,9	75,2	97,7	97,9	95,4

TM30 C values, 16 binned values out of total of 99 C values

C1	C2	C3	C4	C5	C6	C7	C8	C9	C10	C11	C12	C13	C14	C15	C16
92,6	95,7	94,5	92,5	90,6	96,2	93,5	89,5	87,9	84,6	84,4	95,4	93,3	94,3	84,1	95,9

CQS Q values

Q1	Q2	Q3	Q4	Q5	Q6	Q7	Q8	Q9	Q10	Q11	Q12	Q13	Q14	Q15
94,3	99,4	88,1	86,3	91,0	94,9	97,6	98,5	97,2	96,4	95,3	95,7	96,4	97,5	96,6

CQS: 93,8

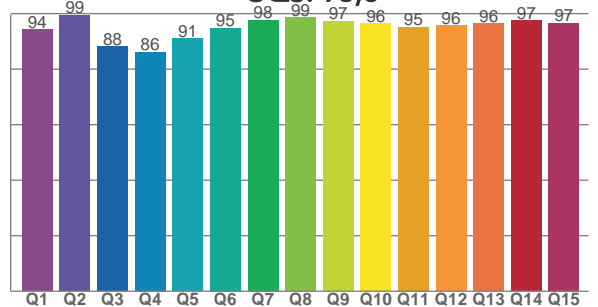

COLOR PARAMETERS

Color temperature	Color rendering index	Red component	Color fidelity	Color gamut	Color quality scale	Television lighting index	Color coordinate cie 1931	Color coordinate cie 1931	Color deviation from black body
CCT	CRI	CRI R9	TM30 Rf	TM30 Rg	CQS	TLCI	x	y	Δuv
5608 K	96,9	97,0	91,2	100,0	93,8	97	0,330	0,336	-0,0047

# TM30 DETAILS

**Rf 91,2**  
Fidelity index Rf

**Rg 100,0**  
Gammut index

Hue Bin	R <sub>f</sub>	Graphic shifts (%)	
		Chroma	Hue
1	93	-1%	1%
2	96	0%	1%
3	95	0%	0%
4	92	-2%	-1%
5	91	-4%	0%
6	96	-1%	0%
7	94	-3%	2%
8	89	-2%	5%
9	88	-2%	10%
10	85	1%	9%
11	84	4%	8%
12	95	3%	1%
13	93	4%	-1%
14	94	1%	-1%
15	84	8%	-8%
16	96	-1%	1%

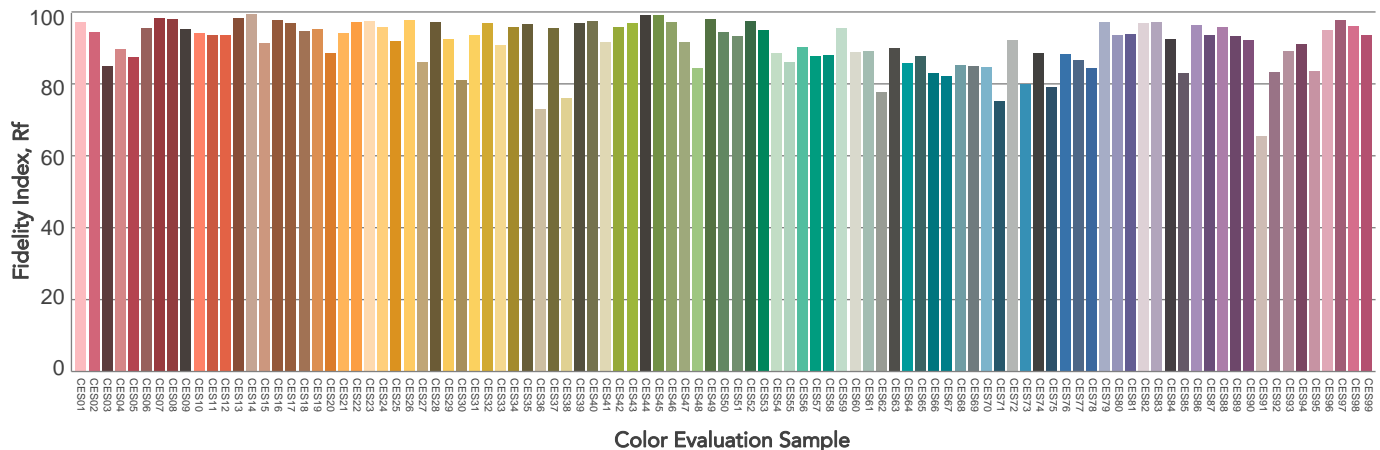
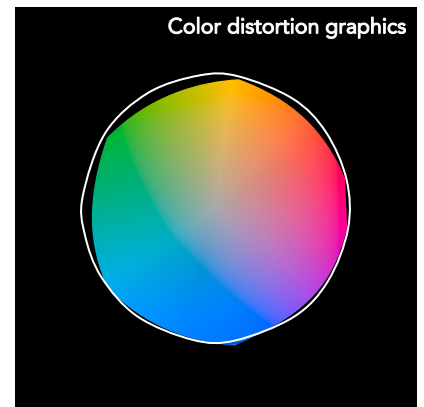
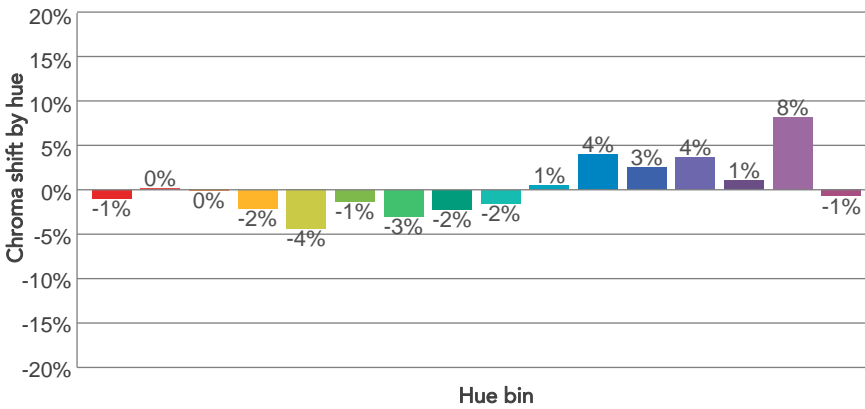
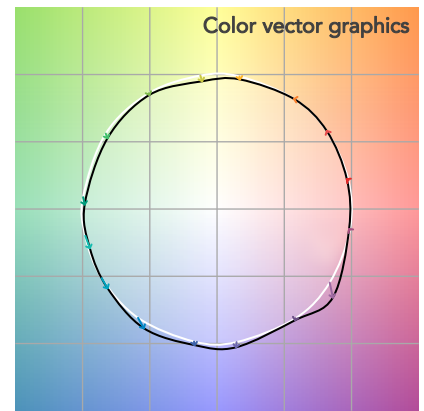
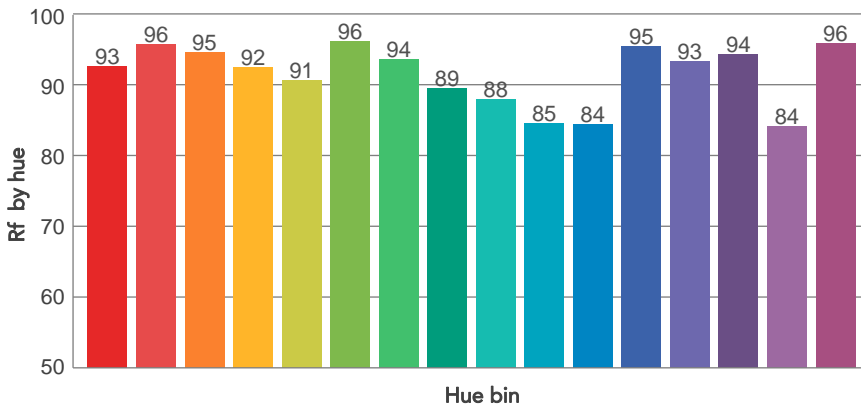
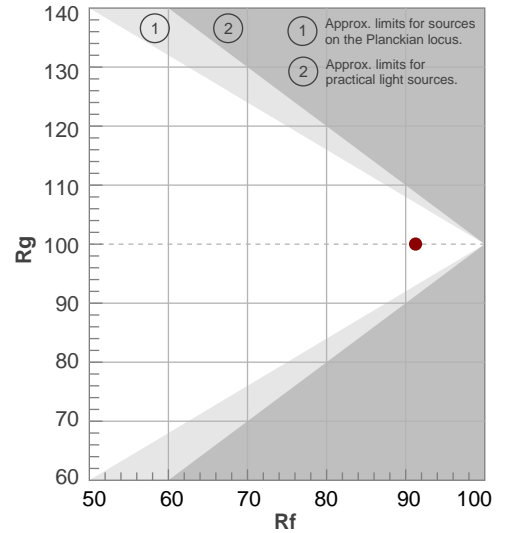

# BEAM DETAILS



Beam angle 50%	Field angle 10%	Cut off angle 2,5%	Intensity ratio in 120° cone	Intensity ratio in 90° cone
35,2°	37,2°	39,7°	100,0%	100,0%

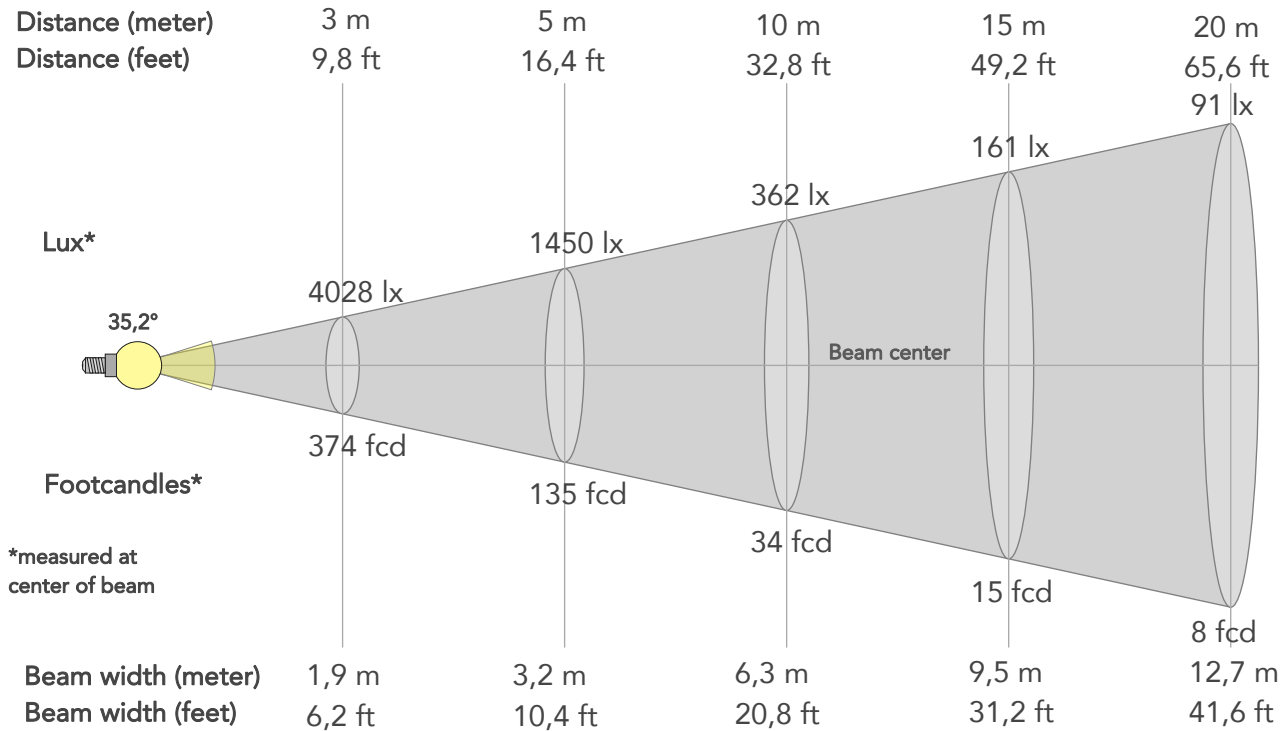

## BEAM INTENSITIES AND WIDTHS

Distance	1m	2m	3m	4m	5m	7,5m	10m	15m	20m	25m	30m	40m	50m
Distance	3,3ft	6,6ft	9,8ft	13,1ft	16,4ft	24,6ft	32,8ft	49,2ft	65,6ft	82ft	98,4ft	131,2ft	164ft
Lux	36249lx	9062lx	4028lx	2266lx	1450lx	644lx	362lx	161lx	91lx	58lx	40lx	23lx	14lx
Footcand.	3368fcd	842fcd	374fcd	210fcd	135fcd	60fcd	34fcd	15fcd	8fcd	5fcd	4fcd	2fcd	1fcd
Beam wid.	0,6m	1,3m	1,9m	2,5m	3,2m	4,8m	6,3m	9,5m	12,7m	15,9m	19m	25,4m	31,7m
Beam wid.	2,1ft	4,2ft	6,2ft	8,3ft	10,4ft	15,6ft	20,8ft	31,2ft	41,6ft	52ft	62,4ft	83,2ft	104ft

## LINEAR DISTRIBUTION DIAGRAM

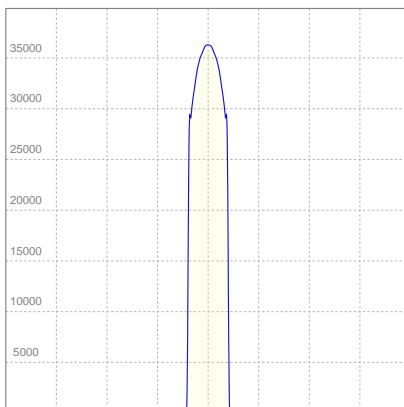

## ELECTRICAL SPECIFICATIONS

Input voltage	Input current	Input power	Effeciency
224V	1,22A	263W	37lm/W
Power Fc			
0,97			



## ISO CANDELA DIAGRAM

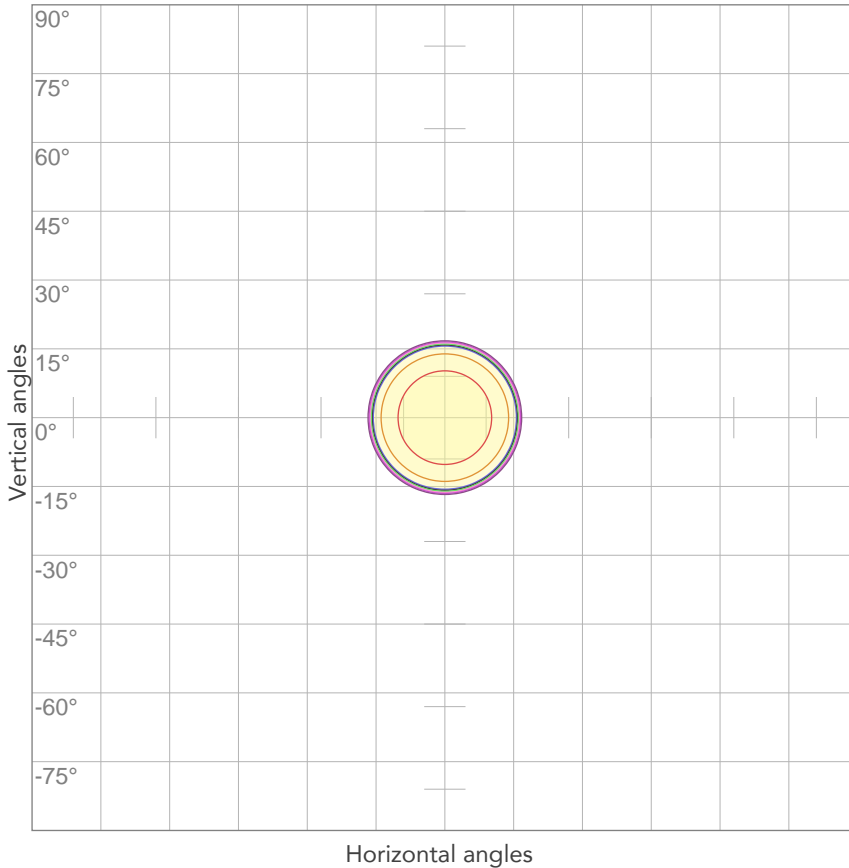

10%	3625 cd
20%	7250 cd
30%	10875 cd
40%	14500 cd
50%	18125 cd
60%	21750 cd
70%	25375 cd
80%	28999 cd

Conditions:

Number of c-planes: 2

Candela at center: 36249 cd

## ISO LUX DIAGRAM

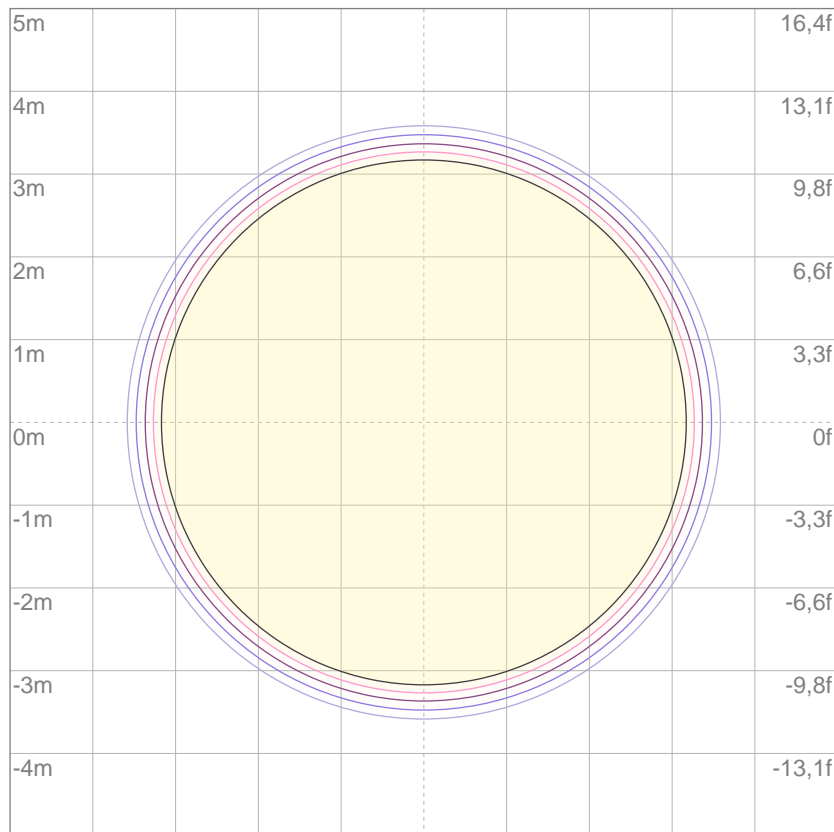

3%	10,9 lx
5%	18,1 lx
10%	36,2 lx
30%	109 lx
50%	181 lx

Conditions:

Number of c-planes: 2

Lux at center: 362 lx

*Lux distribution on a surface when lamp is mounted at 10 meters from the surface.*

Mounting height: 10 meters (33 feet)



Total lumen output:

9017 lm

Peak candela output:

19138 cd

Light quality:

CRI: 97,1

Color temperature:

5602 K

PRODUCT NAME:

ECLFWDY

MEASUREMENT CONDITIONS:

Beam angle:

PRL50

Target:

Cold White

Operator:

Paolo Carvone

Date and time:

17/11/2020 14:27:49

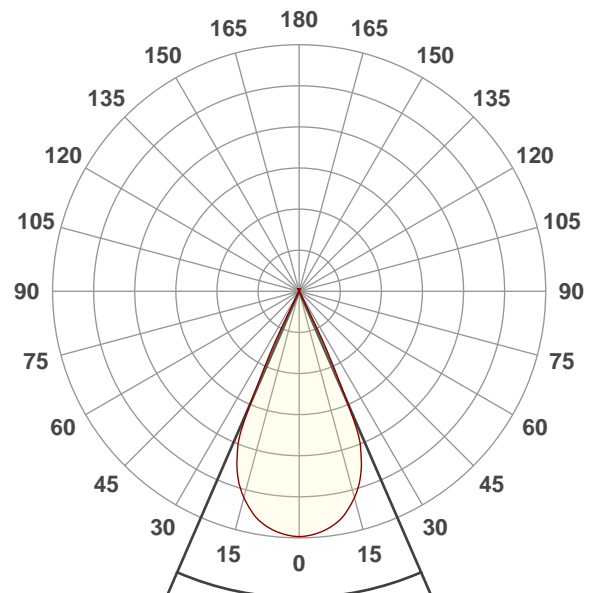

Beam angle 50%: 46,9°

Field angle 10%: 53,4°

Cut off angle 2.5%: 54,8°

Spectra

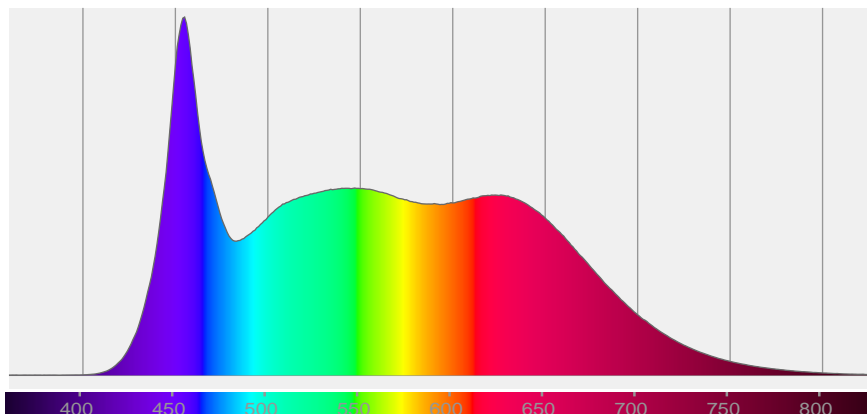

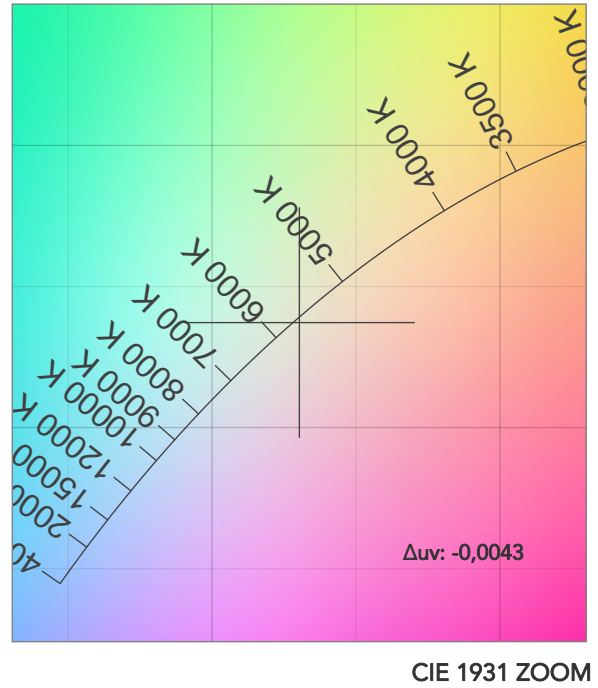
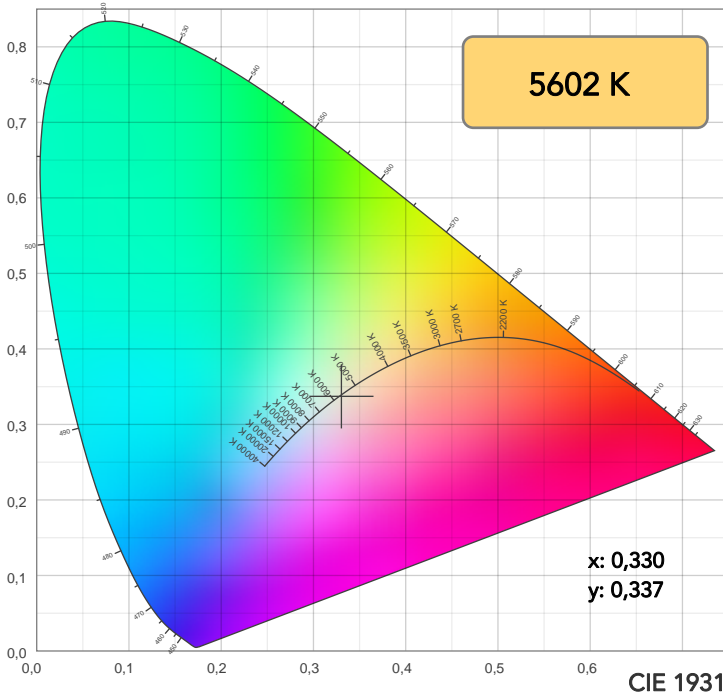

TM30: 91,4

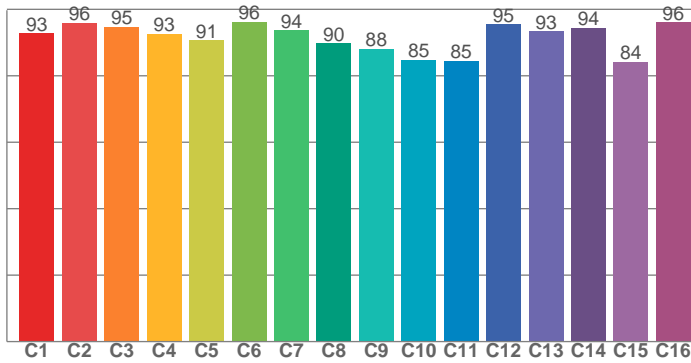

CRI: 97,1 (R1-R8)

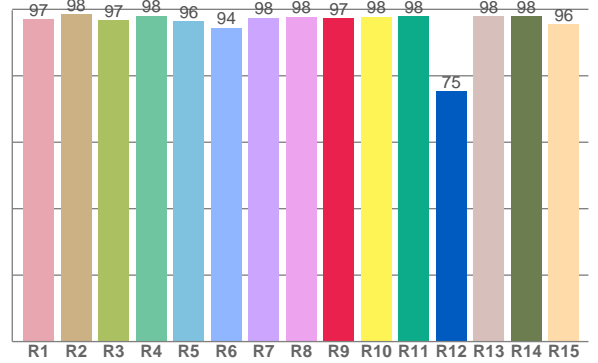

CRI R values, only R1-R8 are used to calculate final CRI value

R1	R2	R3	R4	R5	R6	R7	R8	R9	R10	R11	R12	R13	R14	R15
97,1	98,4	96,8	98,1	96,4	94,5	97,5	97,7	97,3	97,8	98,0	75,3	98,0	97,9	95,6

TM30 C values, 16 binned values out of total of 99 C values

C1	C2	C3	C4	C5	C6	C7	C8	C9	C10	C11	C12	C13	C14	C15	C16
92,8	95,9	94,7	92,6	90,7	96,2	93,7	89,7	88,1	84,8	84,5	95,5	93,4	94,4	84,3	96,0

CQS Q values

Q1	Q2	Q3	Q4	Q5	Q6	Q7	Q8	Q9	Q10	Q11	Q12	Q13	Q14	Q15
94,4	99,4	88,3	86,6	91,3	95,0	97,6	98,5	97,3	96,5	95,5	96,0	96,8	97,6	96,7

CQS: 94,0

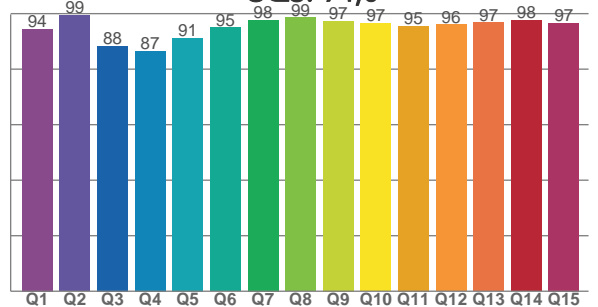

COLOR PARAMETERS

Color temperature	Color rendering index	Red component	Color fidelity	Color gamut	Color quality scale	Television lighting index	Color coordinate cie 1931	Color coordinate cie 1931	Color deviation from black body
CCT	CRI	CRI R9	TM30 Rf	TM30 Rg	CQS	TLCI	x	y	Δuv
5602 K	97,1	97,3	91,4	100,0	94,0	98	0,330	0,337	-0,0043

# TM30 DETAILS

**Rf 91,4**  
Fidelity index Rf

**Rg 100,0**  
Gammut index

Hue Bin	R <sub>f</sub>	Graphic shifts (%)	
		Chroma	Hue
1	93	-1%	1%
2	96	0%	1%
3	95	0%	0%
4	93	-2%	-1%
5	91	-4%	0%
6	96	-1%	0%
7	94	-3%	2%
8	90	-2%	5%
9	88	-2%	10%
10	85	0%	9%
11	85	4%	8%
12	95	2%	1%
13	93	4%	-1%
14	94	1%	-1%
15	84	8%	-8%
16	96	-1%	1%

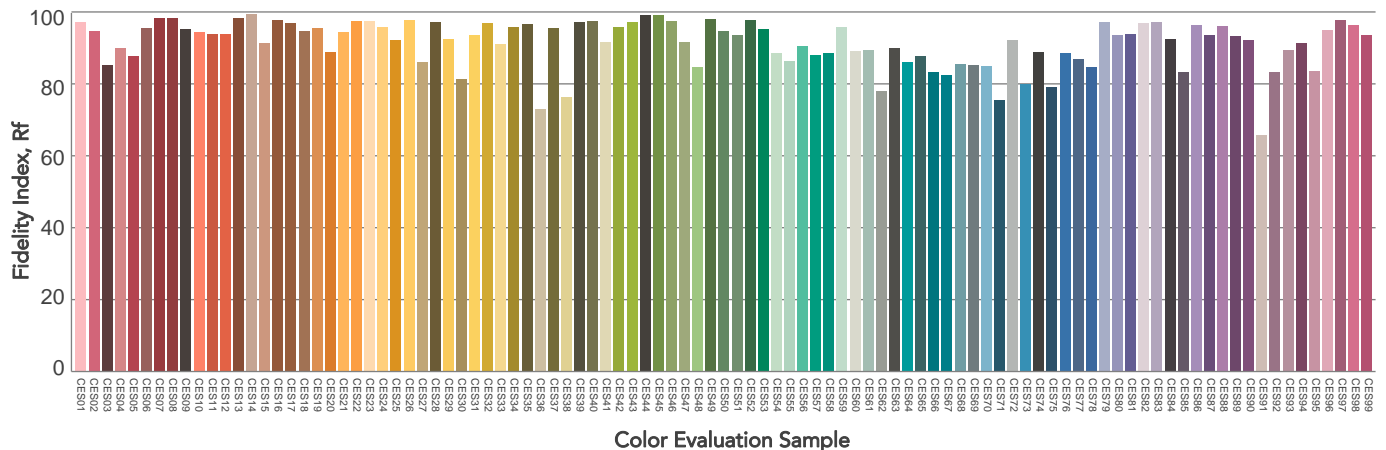
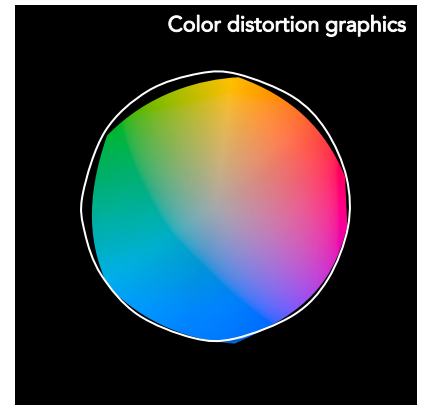
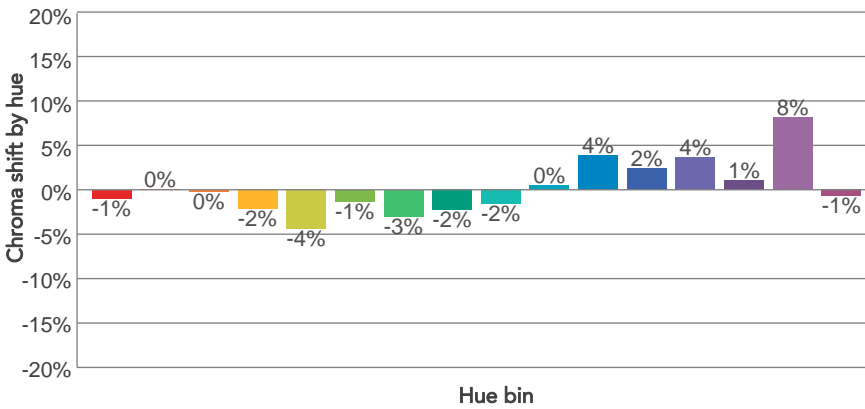
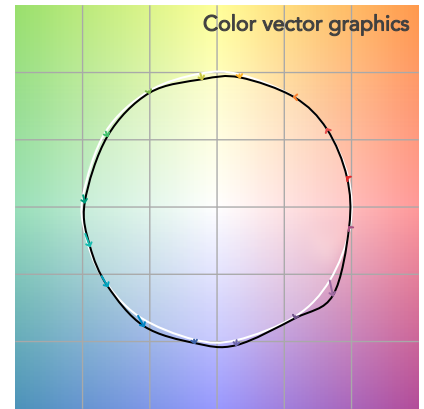
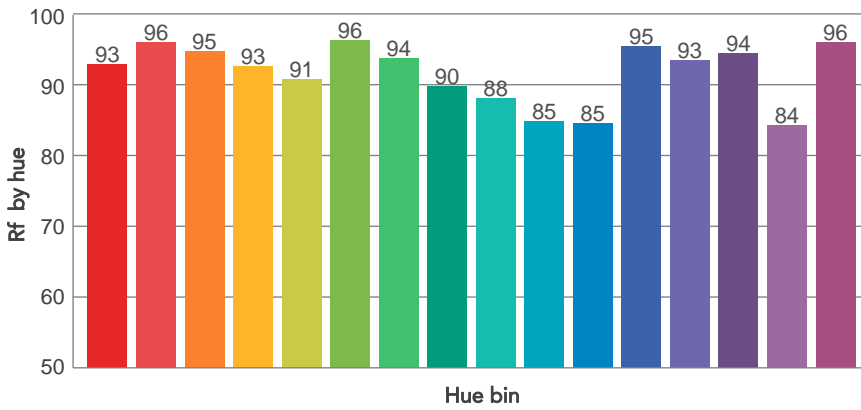
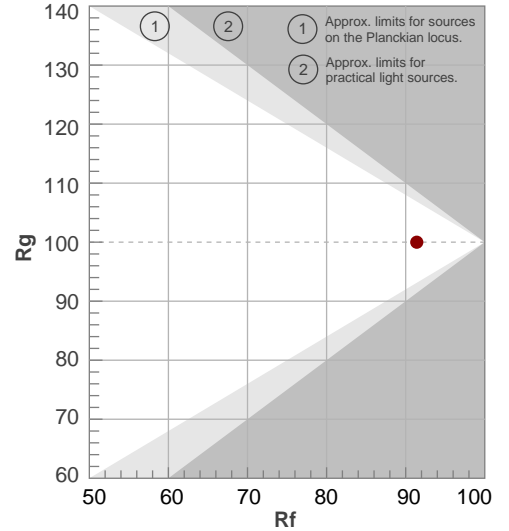

# BEAM DETAILS



Beam angle 50%	Field angle 10%	Cut off angle 2,5%	Intensity ratio in 120° cone	Intensity ratio in 90° cone
46,9°	53,4°	54,8°	100,0%	100,0%

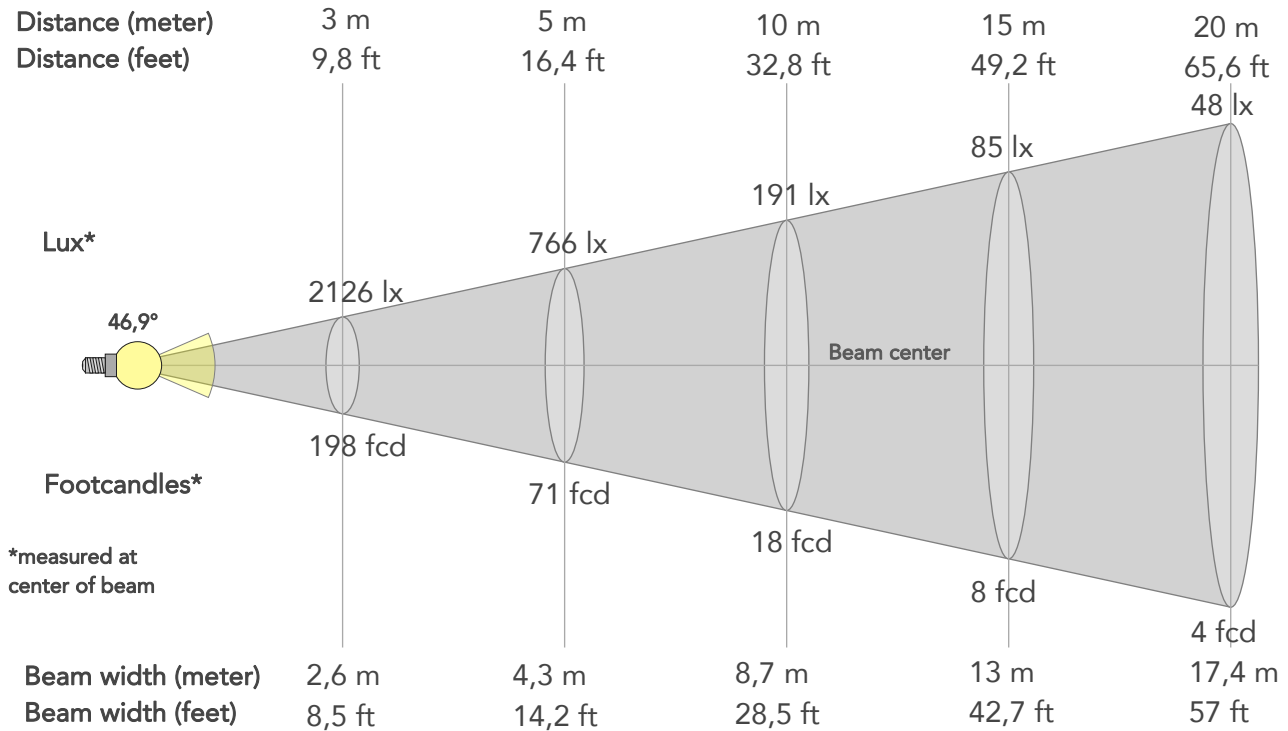

## BEAM INTENSITIES AND WIDTHS

Distance	1m	2m	3m	4m	5m	7,5m	10m	15m	20m	25m	30m	40m	50m
Distance	3,3ft	6,6ft	9,8ft	13,1ft	16,4ft	24,6ft	32,8ft	49,2ft	65,6ft	82ft	98,4ft	131,2ft	164ft
Lux	19138lx	4784lx	2126lx	1196lx	766lx	340lx	191lx	85lx	48lx	31lx	21lx	12lx	8lx
Footcand.	1778fcd	444fcd	198fcd	111fcd	71fcd	32fcd	18fcd	8fcd	4fcd	3fcd	2fcd	1fcd	1fcd
Beam wid.	0,9m	1,7m	2,6m	3,5m	4,3m	6,5m	8,7m	13m	17,4m	21,7m	26m	34,7m	43,4m
Beam wid.	2,9ft	5,7ft	8,5ft	11,4ft	14,2ft	21,4ft	28,5ft	42,7ft	57ft	71,2ft	85,4ft	113,9ft	142,4ft

## LINEAR DISTRIBUTION DIAGRAM

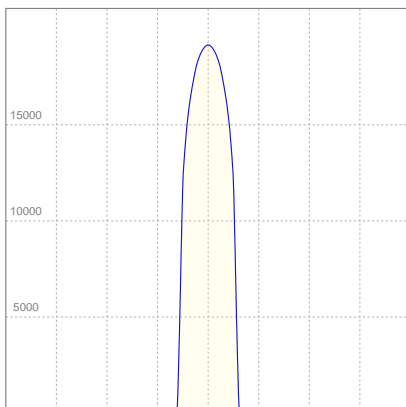

## ELECTRICAL SPECIFICATIONS

Input voltage	Input current	Input power	Effeciency
224V	1,22A	263W	34lm/W
Power Fc			
0,97			

## ISO CANDELA DIAGRAM

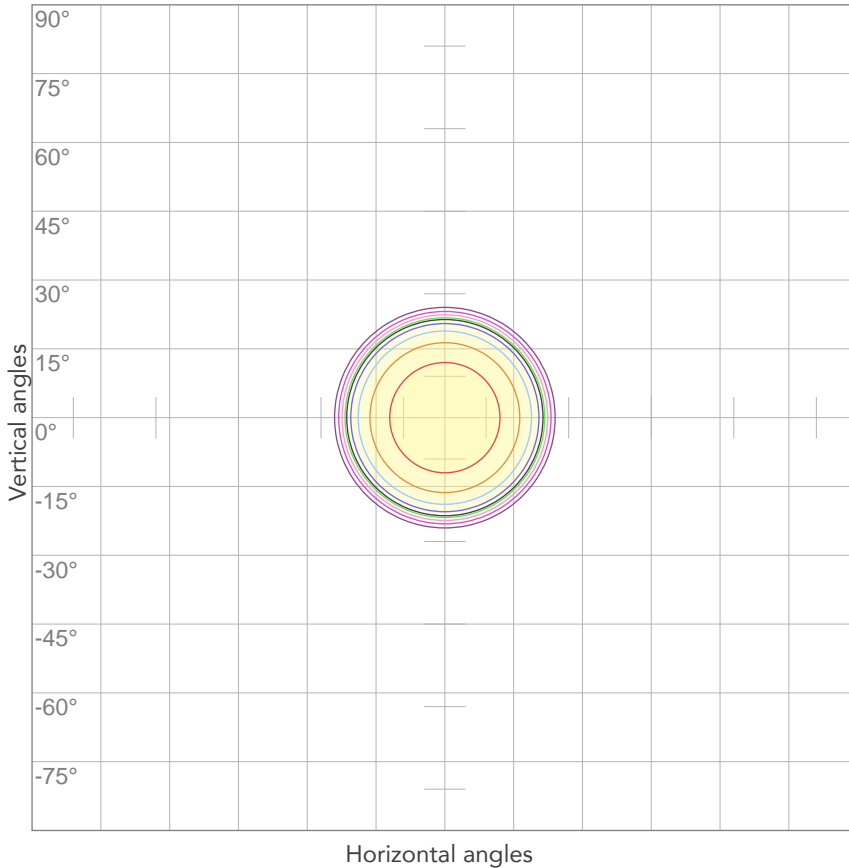

10%	1914 cd
20%	3828 cd
30%	5741 cd
40%	7655 cd
50%	9569 cd
60%	11483 cd
70%	13396 cd
80%	15310 cd

Conditions:

Number of c-planes: 2

Candela at center: 19138 cd

## ISO LUX DIAGRAM

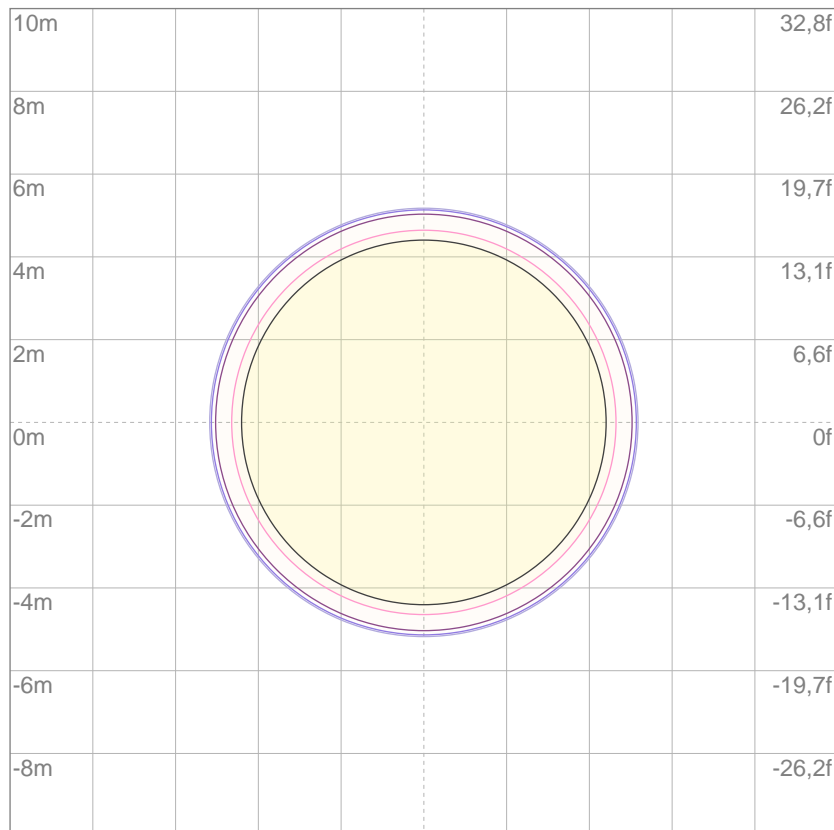

3%	5,74 lx
5%	9,57 lx
10%	19,1 lx
30%	57,4 lx
50%	95,7 lx

Conditions:

Number of c-planes: 2

Lux at center: 191 lx

*Lux distribution on a surface when lamp is mounted at 10 meters from the surface.*

Mounting height: 10 meters (33 feet)



Total lumen output:

11708 lm

Peak candela output:

12349 cd

Light quality:

CRI: 97,0

Color temperature:

5558 K

PRODUCT NAME:

ECLFWDY

MEASURAMENT CONDITIONS:

Beam angle:

PRL70

Target:

Cold White

Operator:

Paolo Carvone

Date and time:

23/11/2020 13:28:57

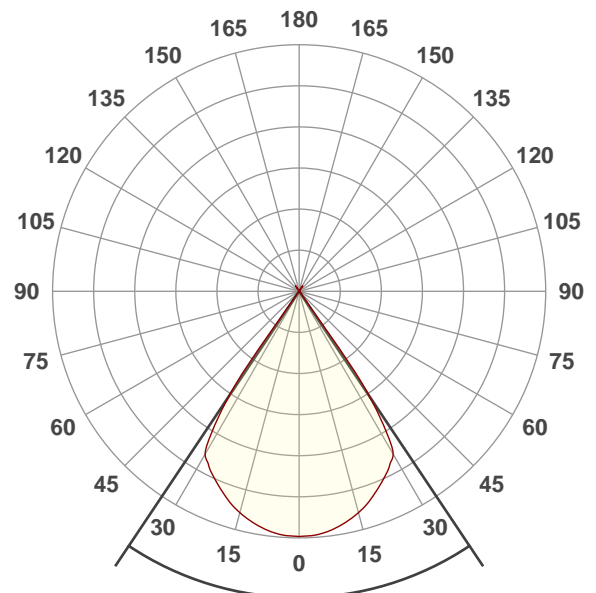

Beam angle 50%: 67,6°

Field angle 10%: 74,2°

Cut off angle 2.5%: 75,3°

Spectra

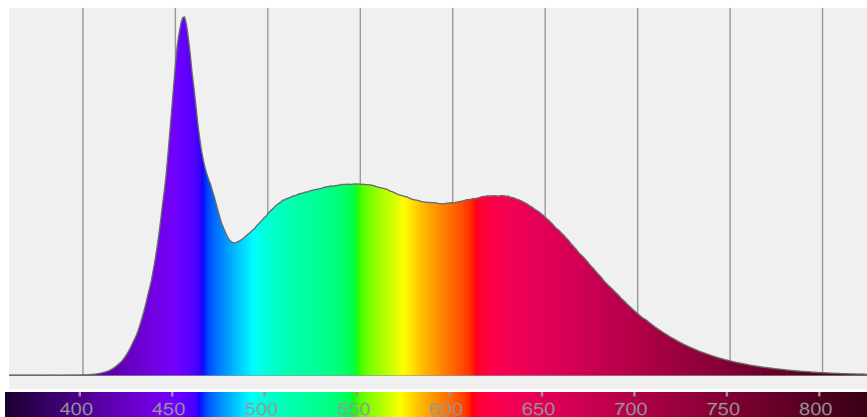

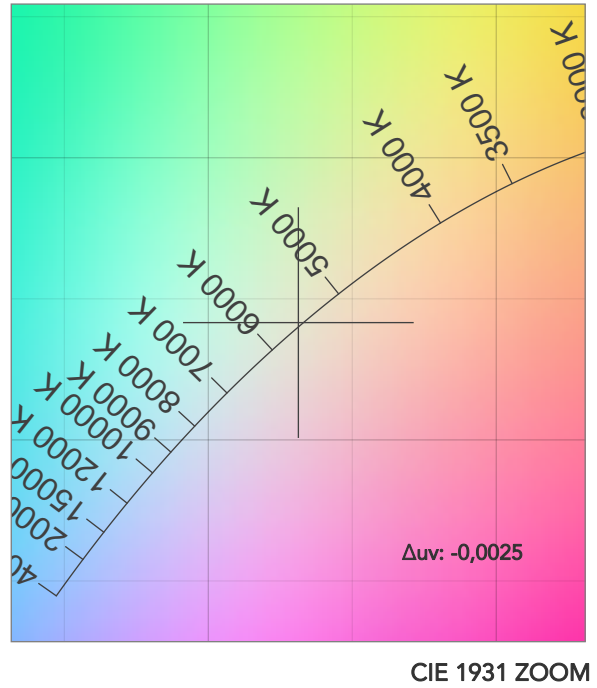
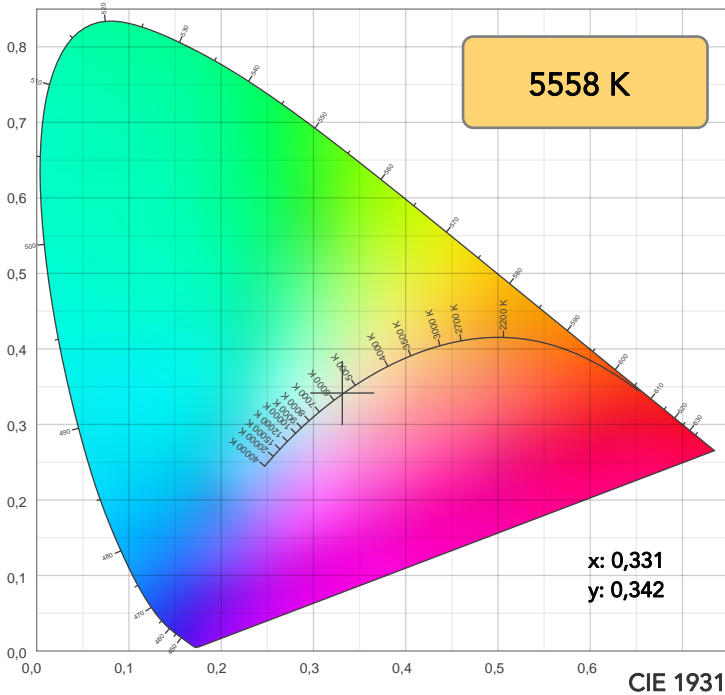

TM30: 91,3

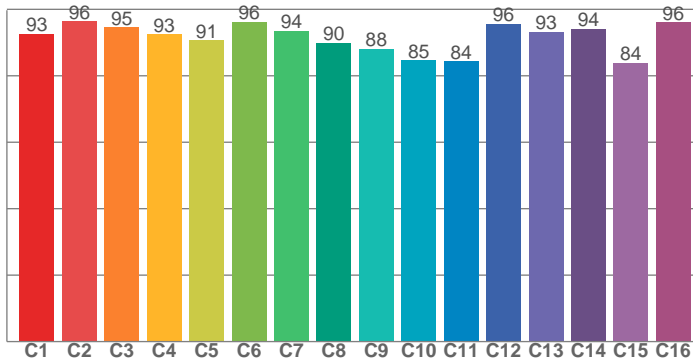

CRI: 97,0 (R1-R8)

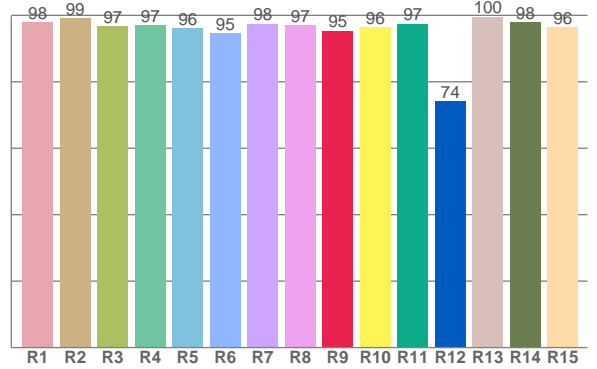

CRI R values, only R1-R8 are used to calculate final CRI value

R1	R2	R3	R4	R5	R6	R7	R8	R9	R10	R11	R12	R13	R14	R15
97,8	99,0	96,6	97,1	96,2	94,6	97,5	97,0	95,4	96,4	97,5	74,1	99,6	97,9	96,4

TM30 C values, 16 binned values out of total of 99 C values

C1	C2	C3	C4	C5	C6	C7	C8	C9	C10	C11	C12	C13	C14	C15	C16
92,7	96,4	94,6	92,5	90,7	96,3	93,5	89,9	88,1	84,6	84,3	95,6	93,2	94,1	83,9	96,1

CQS Q values

Q1	Q2	Q3	Q4	Q5	Q6	Q7	Q8	Q9	Q10	Q11	Q12	Q13	Q14	Q15
94,0	99,2	88,4	86,5	91,0	94,3	97,1	98,0	97,7	96,6	95,6	96,3	97,2	97,6	96,5

CQS: 93,9

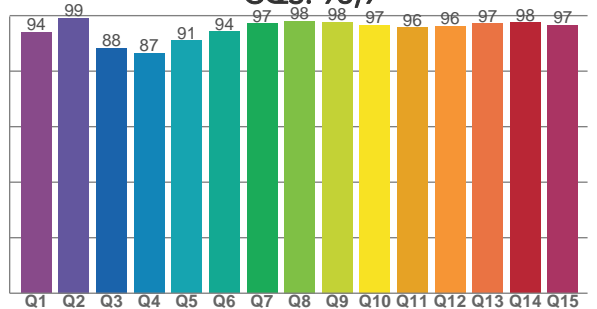

COLOR PARAMETERS

Color temperature	Color rendering index	Red component	Color fidelity	Color gamut	Color quality scale	Television lighting index	Color coordinate cie 1931	Color coordinate cie 1931	Color deviation from black body
CCT	CRI	CRI R9	TM30 Rf	TM30 Rg	CQS	TLCI	x	y	Δuv
5558 K	97,0	95,4	91,3	99,4	93,9	98	0,331	0,342	-0,0025



# TM30 DETAILS

**Rf 91,3**  
Fidelity index Rf

**Rg 99,4**  
Gammut index

Hue Bin	R <sub>f</sub>	Graphic shifts (%)	
		Chroma	Hue
1	93	-1%	1%
2	96	0%	1%
3	95	-1%	0%
4	93	-2%	-1%
5	91	-5%	0%
6	96	-1%	0%
7	94	-3%	2%
8	90	-3%	5%
9	88	-2%	10%
10	85	0%	9%
11	84	4%	8%
12	96	2%	1%
13	93	4%	-1%
14	94	1%	-2%
15	84	8%	-9%
16	96	-1%	0%

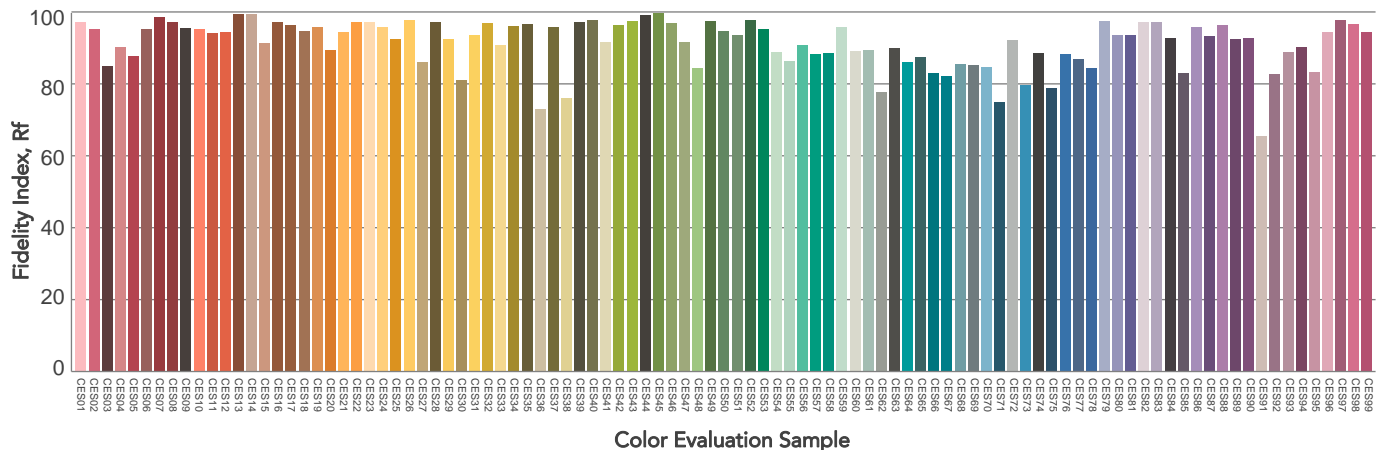
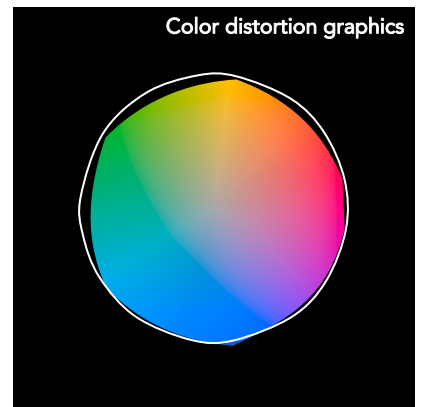
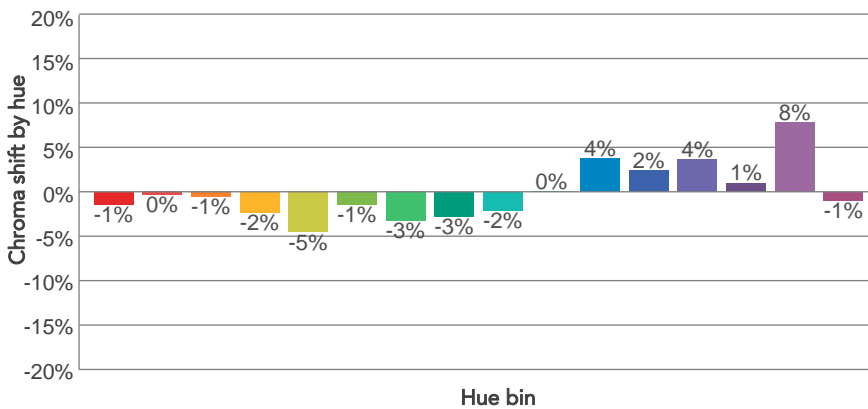
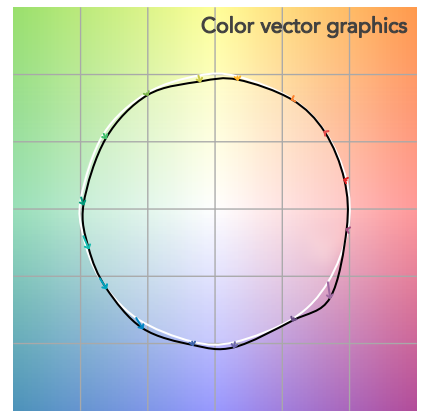
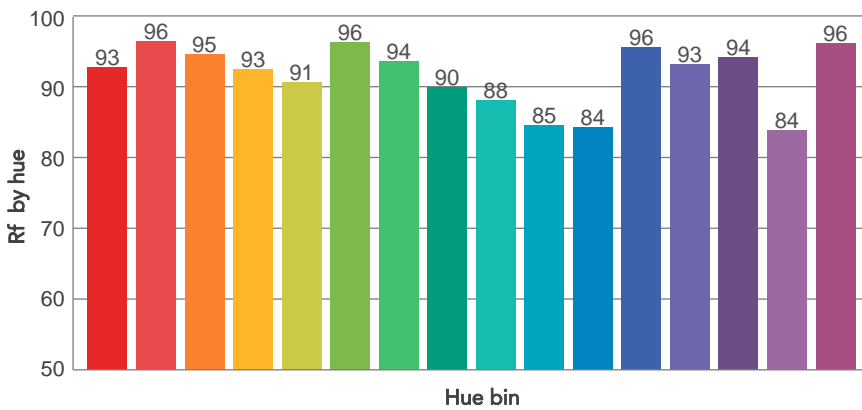
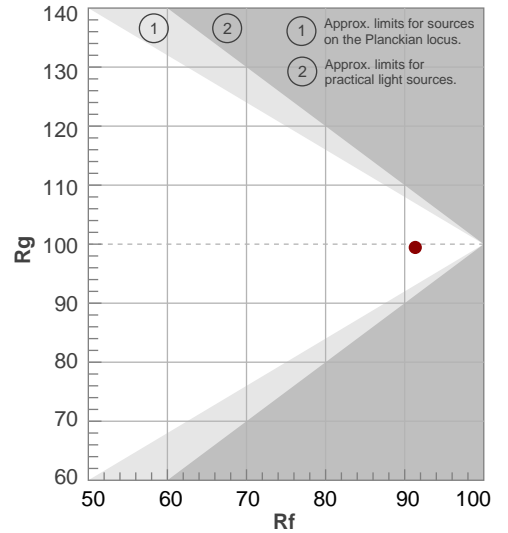

# BEAM DETAILS



Beam angle 50%	Field angle 10%	Cut off angle 2,5%	Intensity ratio in 120° cone	Intensity ratio in 90° cone
67,6°	74,2°	75,3°	100,0%	100,0%

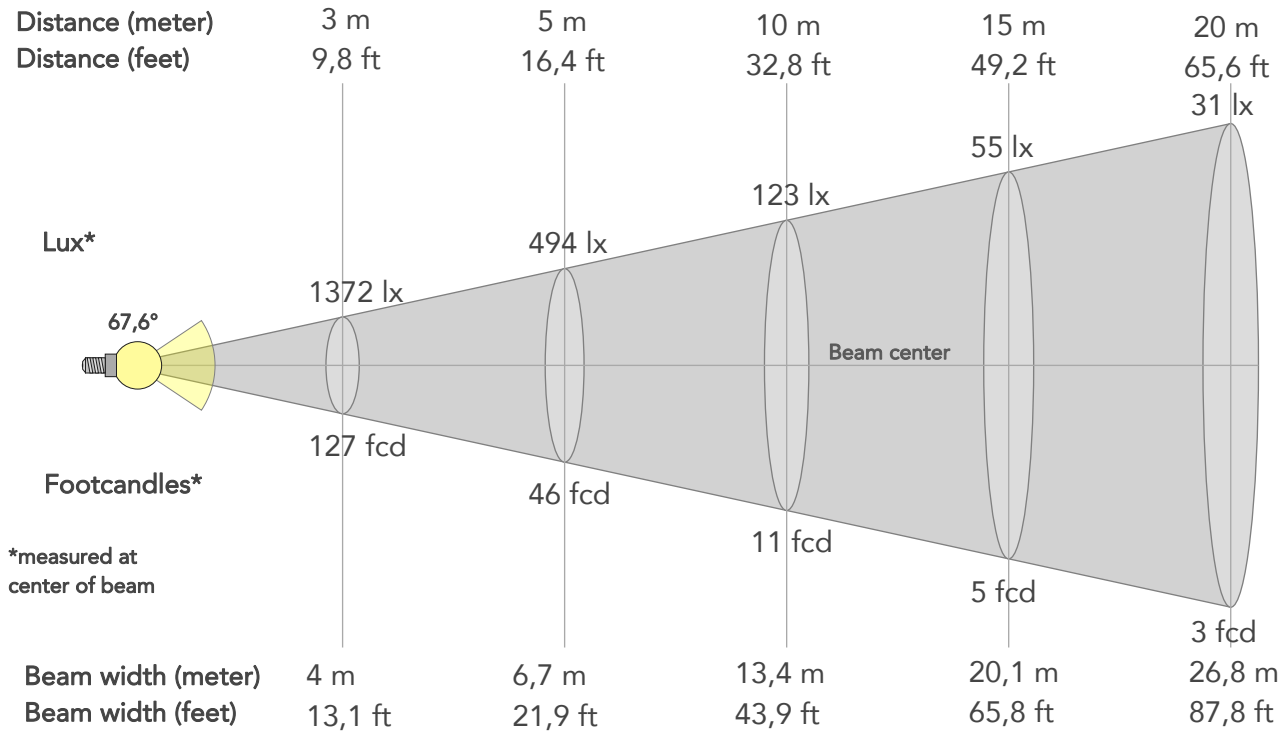

## BEAM INTENSITIES AND WIDTHS

Distance	1m	2m	3m	4m	5m	7,5m	10m	15m	20m	25m	30m	40m	50m
Distance	3,3ft	6,6ft	9,8ft	13,1ft	16,4ft	24,6ft	32,8ft	49,2ft	65,6ft	82ft	98,4ft	131,2ft	164ft
Lux	12349lx	3087lx	1372lx	772lx	494lx	220lx	123lx	55lx	31lx	20lx	14lx	8lx	5lx
Footcand.	1147fcd	287fcd	127fcd	72fcd	46fcd	20fcd	11fcd	5fcd	3fcd	2fcd	1fcd	1fcd	0fcd
Beam wid.	1,3m	2,7m	4m	5,4m	6,7m	10m	13,4m	20,1m	26,8m	33,5m	40,1m	53,5m	66,9m
Beam wid.	4,4ft	8,8ft	13,1ft	17,5ft	21,9ft	32,9ft	43,9ft	65,8ft	87,8ft	109,7ft	131,7ft	175,6ft	219,5ft

## LINEAR DISTRIBUTION DIAGRAM

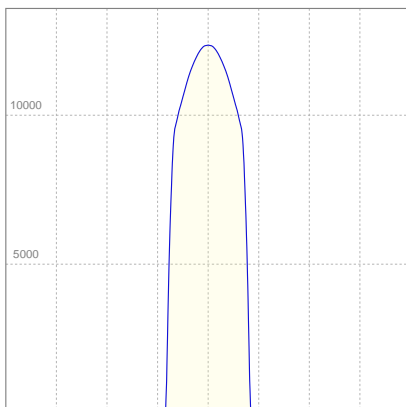

## ELECTRICAL SPECIFICATIONS

Input voltage	Input current	Input power	Effeciency
224V	1,21A	261,8W	45lm/W

Power Fc
0,97

## ISO CANDELA DIAGRAM

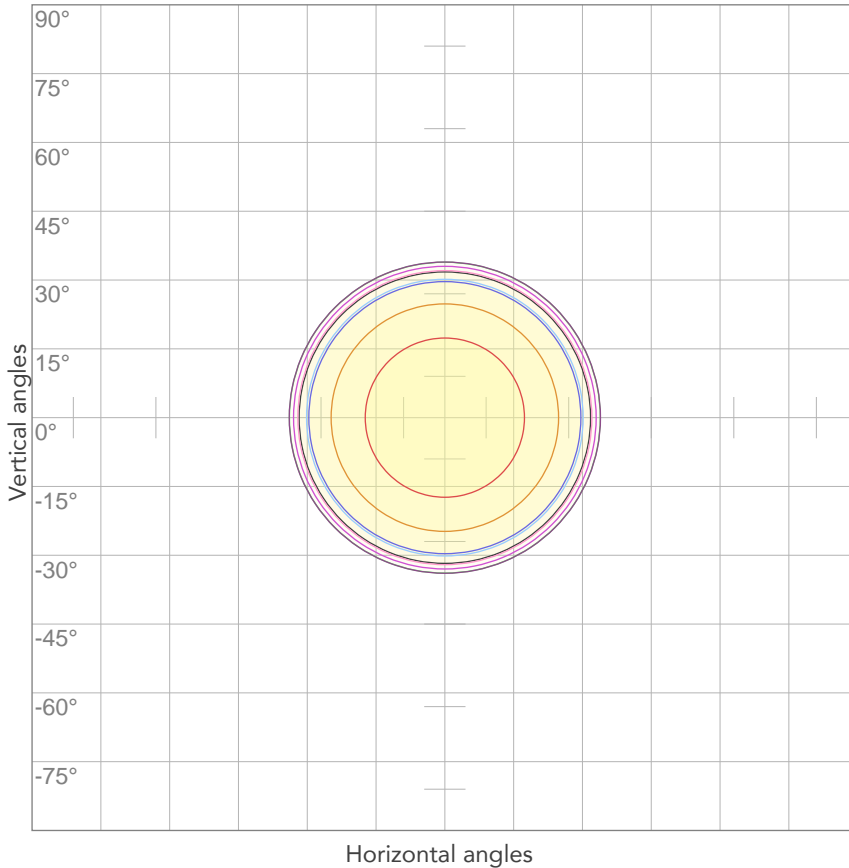

10%	1235 cd
20%	2470 cd
30%	3705 cd
40%	4940 cd
50%	6175 cd
60%	7410 cd
70%	8644 cd
80%	9879 cd

Conditions:

Number of c-planes: 2

Candela at center: 12349 cd

## ISO LUX DIAGRAM

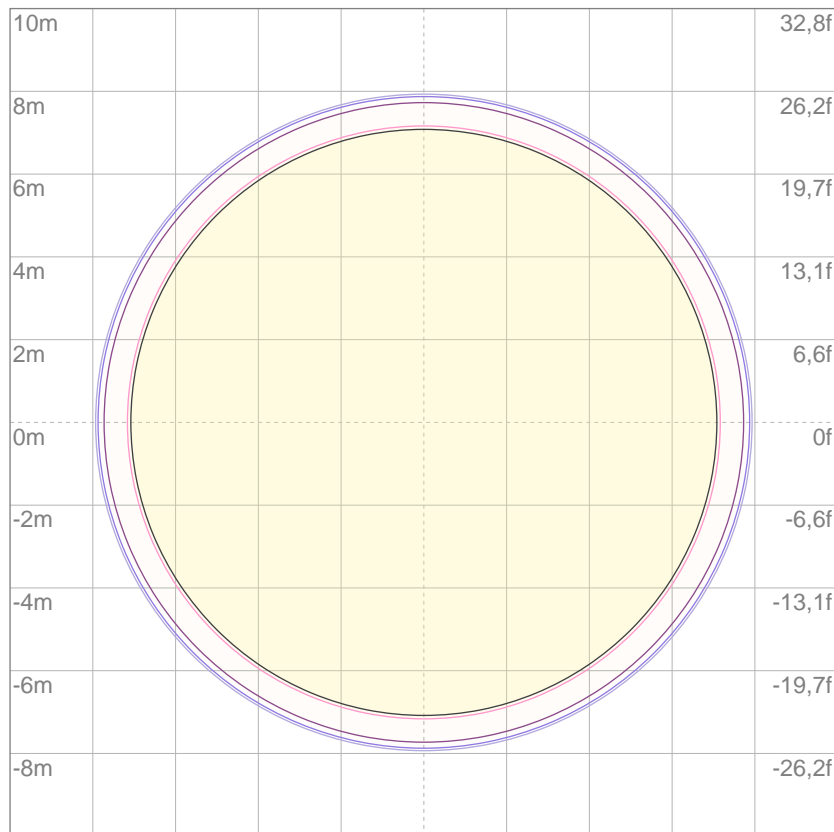

3%	3,70 lx
5%	6,17 lx
10%	12,3 lx
30%	37,0 lx
50%	61,7 lx

Conditions:

Number of c-planes: 2

Lux at center: 123 lx

*Lux distribution on a surface when lamp is mounted at 10 meters from the surface.*

Mounting height: 10 meters (33 feet)



Total lumen output:

8873 lm

Peak candela output:

50417 cd

Light quality:

CRI: 96,8

Color temperature:

5673 K

**PRODUCT NAME:**  
ECLFWDY

**MEASURAMENT CONDITIONS:**

Beam angle:  
PRL15-30 Max Zoom

Target:  
Cold White

Operator:  
Paolo Carvone

Date and time:  
17/11/2020 14:36:58

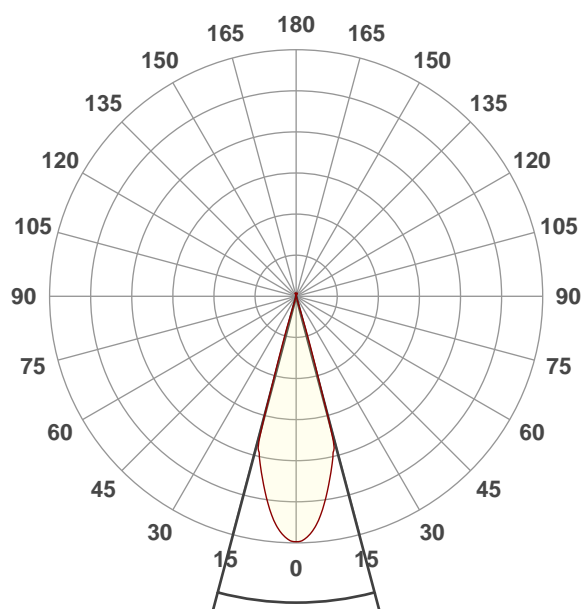

Beam angle 50%: 29,7°  
Field angle 10%: 33,2°  
Cut off angle 2.5%: 34,2°

Spectra

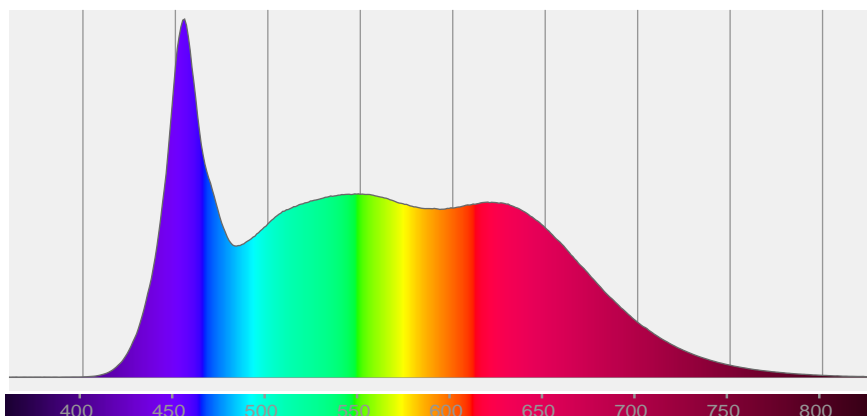

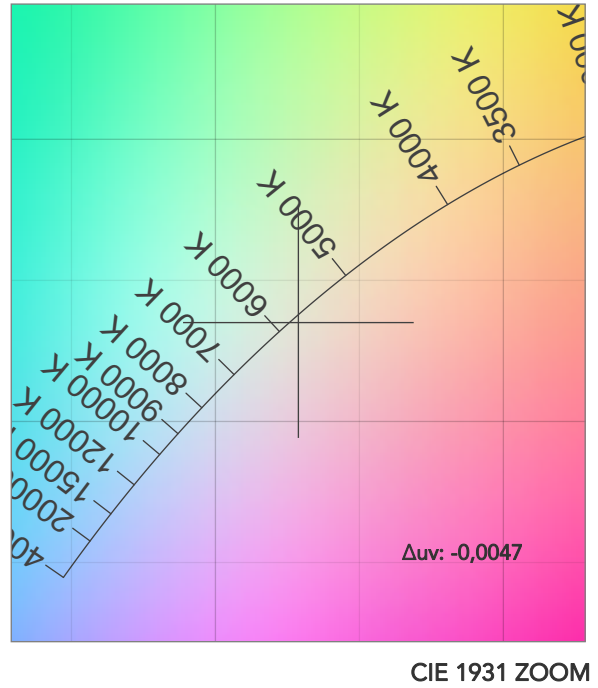
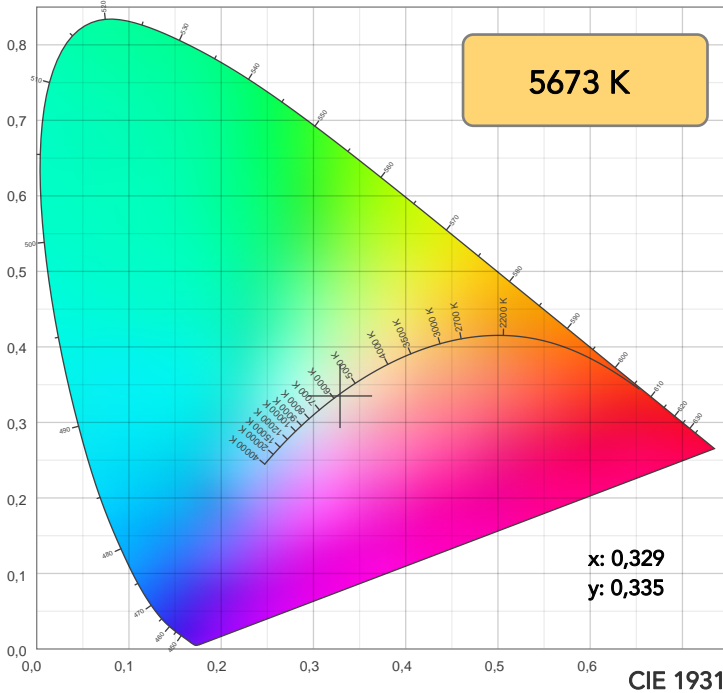

TM30: 91,0

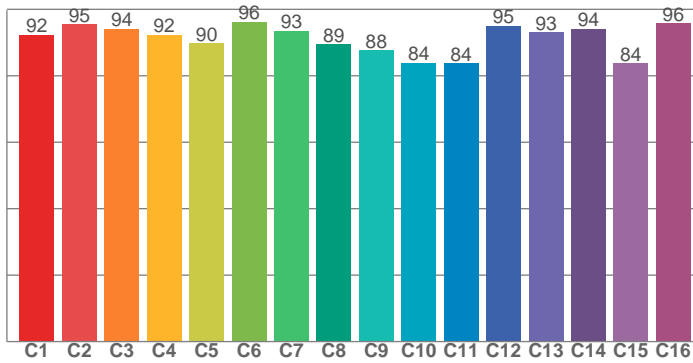

CRI: 96,8 (R1-R8)

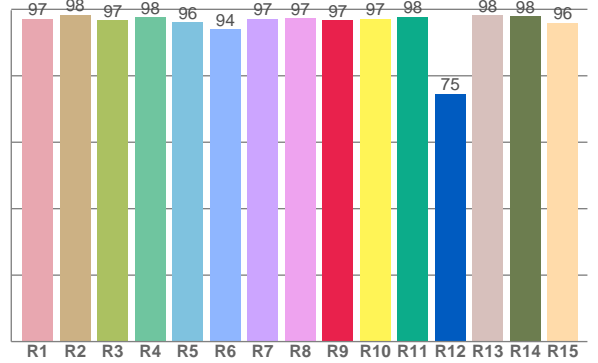

CRI R values, only R1-R8 are used to calculate final CRI value

R1	R2	R3	R4	R5	R6	R7	R8	R9	R10	R11	R12	R13	R14	R15
97,1	98,4	96,6	97,6	96,1	94,0	97,1	97,3	96,8	97,2	97,8	74,6	98,2	97,8	95,9

TM30 C values, 16 binned values out of total of 99 C values

C1	C2	C3	C4	C5	C6	C7	C8	C9	C10	C11	C12	C13	C14	C15	C16
92,3	95,4	94,1	92,3	89,7	96,2	93,4	89,4	87,7	83,9	83,8	95,1	93,0	94,1	83,8	95,8

CQS Q values

Q1	Q2	Q3	Q4	Q5	Q6	Q7	Q8	Q9	Q10	Q11	Q12	Q13	Q14	Q15
94,2	99,4	87,5	85,4	90,3	94,2	97,3	98,2	97,1	95,9	94,5	95,0	95,9	97,1	96,3

CQS: 93,4

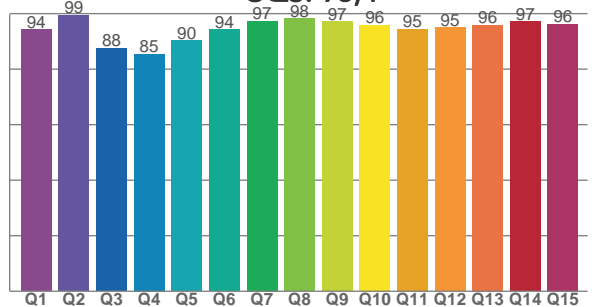

COLOR PARAMETERS

Color temperature	Color rendering index	Red component	Color fidelity	Color gamut	Color quality scale	Television lighting index	Color coordinate cie 1931	Color coordinate cie 1931	Color deviation from black body
CCT	CRI	CRI R9	TM30 Rf	TM30 Rg	CQS	TLCI	x	y	Δuv
5673 K	96,8	96,8	91,0	99,8	93,4	97	0,329	0,335	-0,0047

# TM30 DETAILS

**Rf 91,0**  
Fidelity index Rf

**Rg 99,8**  
Gammut index

Hue Bin	R <sub>f</sub>	Graphic shifts (%)	
		Chroma	Hue
1	92	-1%	1%
2	95	0%	1%
3	94	0%	1%
4	92	-2%	0%
5	90	-4%	0%
6	96	-1%	0%
7	93	-3%	2%
8	89	-2%	5%
9	88	-2%	10%
10	84	0%	9%
11	84	4%	8%
12	95	3%	1%
13	93	4%	-1%
14	94	1%	-1%
15	84	8%	-9%
16	96	-1%	0%

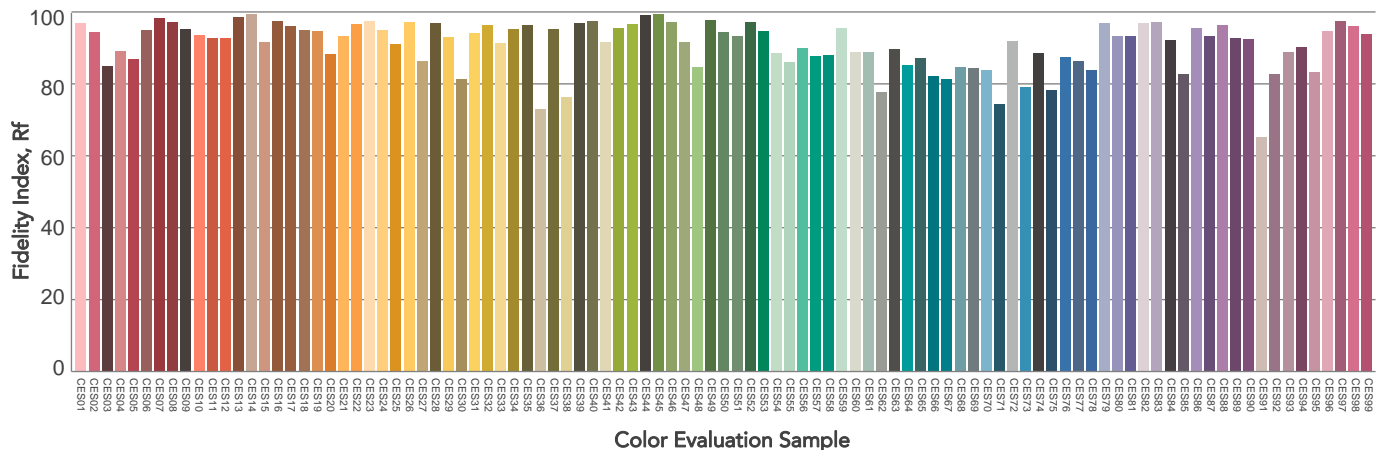
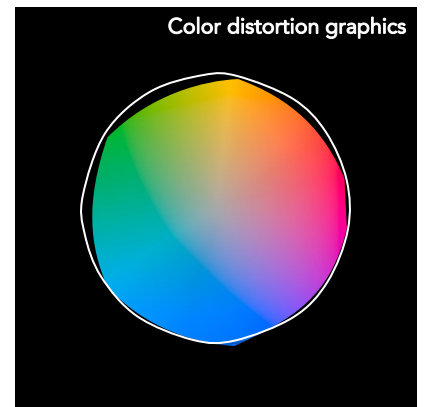
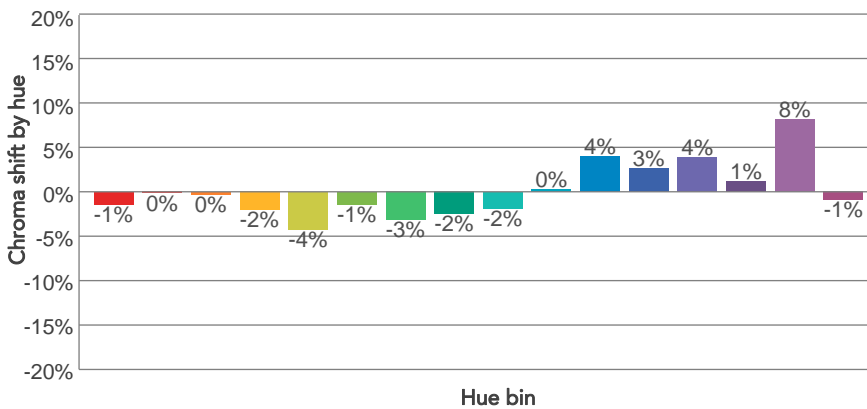
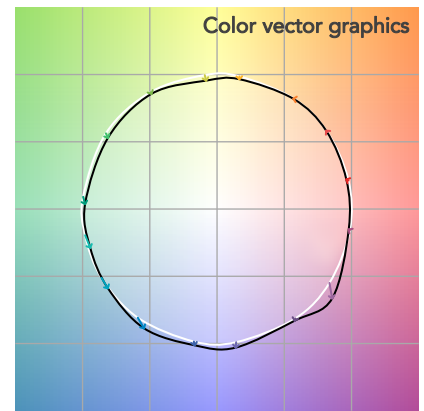
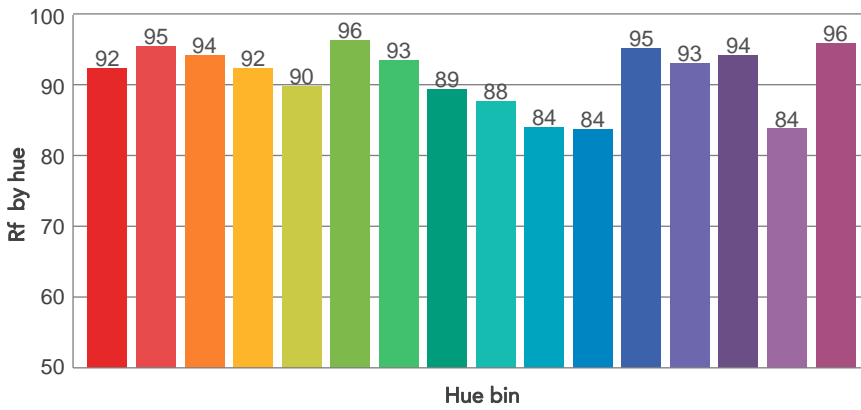
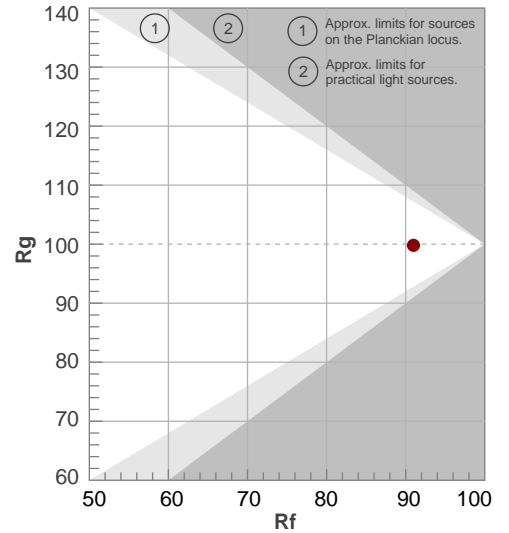

# BEAM DETAILS



Beam angle 50%	Field angle 10%	Cut off angle 2,5%	Intensity ratio in 120° cone	Intensity ratio in 90° cone
29,7°	33,2°	34,2°	100,0%	100,0%

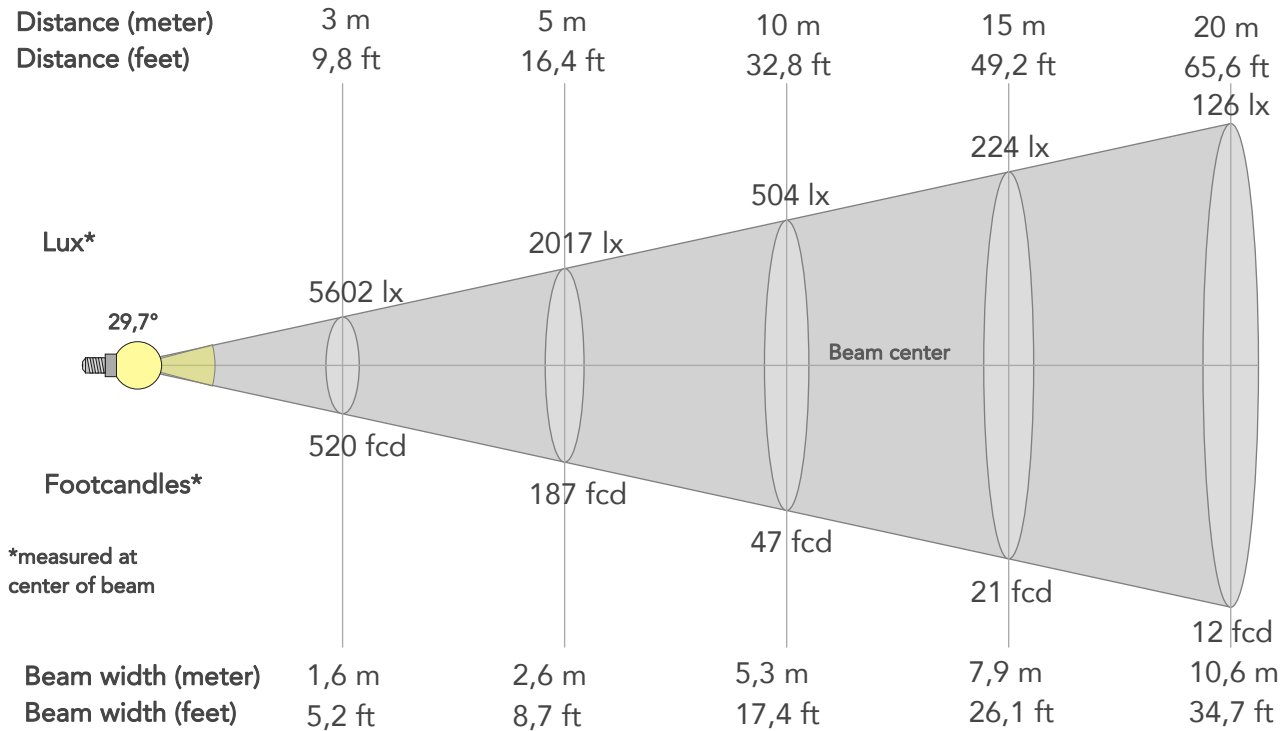

## BEAM INTENSITIES AND WIDTHS

Distance	1m	2m	3m	4m	5m	7,5m	10m	15m	20m	25m	30m	40m	50m
Distance	3,3ft	6,6ft	9,8ft	13,1ft	16,4ft	24,6ft	32,8ft	49,2ft	65,6ft	82ft	98,4ft	131,2ft	164ft
Lux	50417lx	12604lx	5602lx	3151lx	2017lx	896lx	504lx	224lx	126lx	81lx	56lx	32lx	20lx
Footcand.	4684fcd	1171fcd	520fcd	293fcd	187fcd	83fcd	47fcd	21fcd	12fcd	7fcd	5fcd	3fcd	2fcd
Beam wid.	0,5m	1,1m	1,6m	2,1m	2,6m	4m	5,3m	7,9m	10,6m	13,2m	15,9m	21,2m	26,5m
Beam wid.	1,7ft	3,5ft	5,2ft	6,9ft	8,7ft	13ft	17,4ft	26,1ft	34,7ft	43,4ft	52,1ft	69,5ft	86,9ft

## LINEAR DISTRIBUTION DIAGRAM

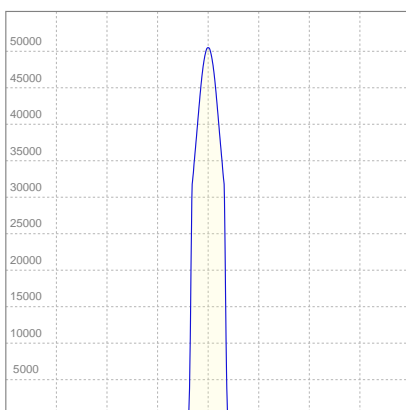

## ELECTRICAL SPECIFICATIONS

Input voltage	Input current	Input power	Effeciency
224V	1,22A	262,7W	34lm/W
Power Fc			
0,97			

## ISO CANDELA DIAGRAM

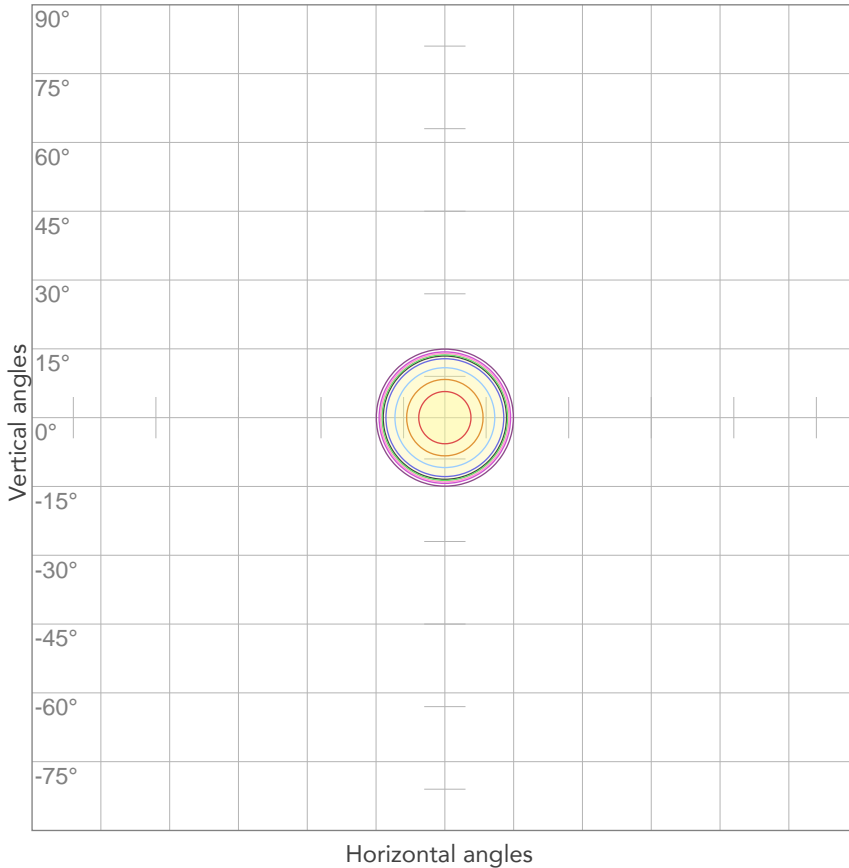

10%	5042 cd
20%	10083 cd
30%	15125 cd
40%	20167 cd
50%	25208 cd
60%	30250 cd
70%	35292 cd
80%	40333 cd

**Conditions:**

Number of c-planes: 2

Candela at center: 50417 cd

## ISO LUX DIAGRAM

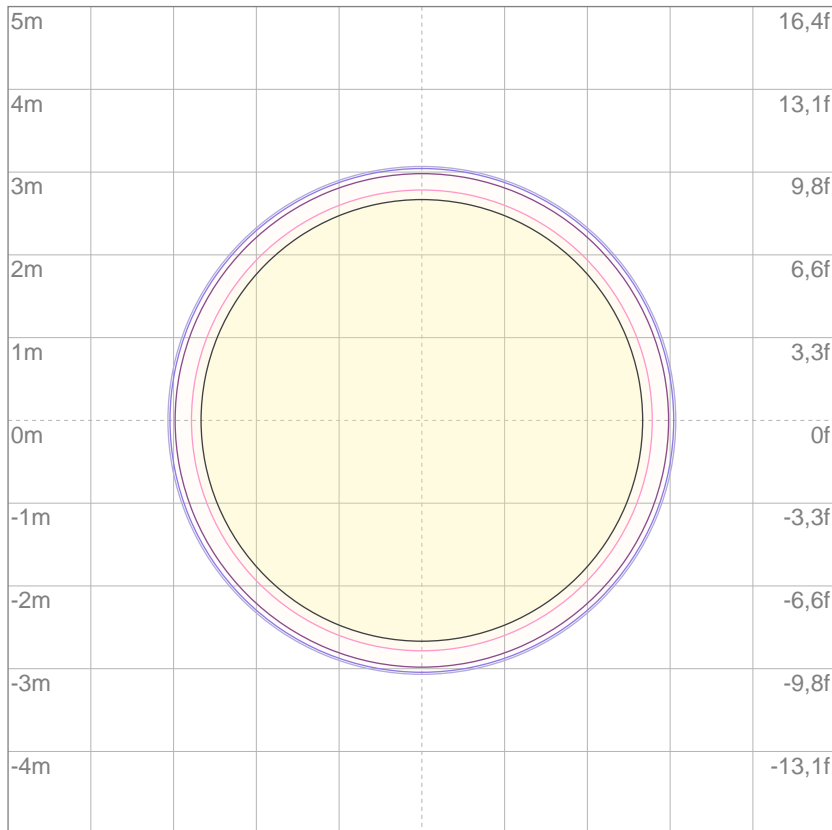

3%	15,1 lx
5%	25,2 lx
10%	50,4 lx
30%	151 lx
50%	252 lx

**Conditions:**

Number of c-planes: 2

Lux at center: 504 lx

*Lux distribution on a surface when lamp is mounted at 10 meters from the surface.*

Mounting height: 10 meters (33 feet)





Total lumen output:

8085 lm

Peak candela output:

152591 cd

Light quality:

CRI: 96,8

Color temperature:

5673 K

**PRODUCT NAME:**  
ECLFWDY

**MEASURAMENT CONDITIONS:**

Beam angle:  
PRL15-30 Min Zoom

Target:  
Cold White

Operator:  
Paolo Carvone

Date and time:  
17/11/2020 14:35:08

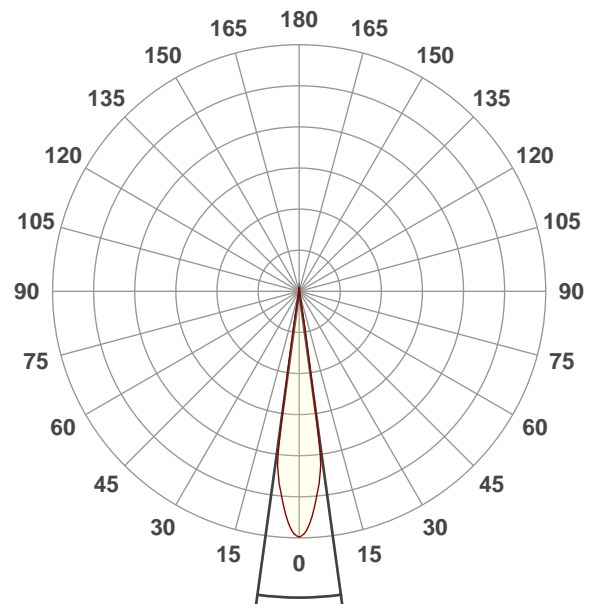

Beam angle 50%: 15,7°  
Field angle 10%: 18,4°  
Cut off angle 2.5%: 19,3°

Spectra

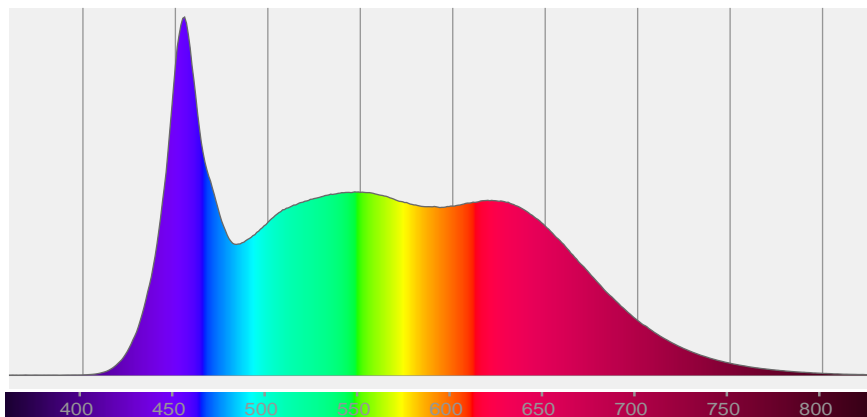

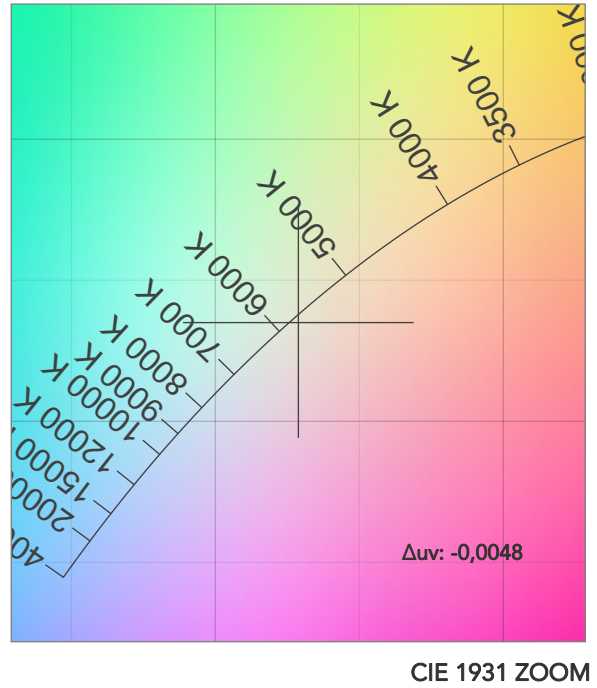
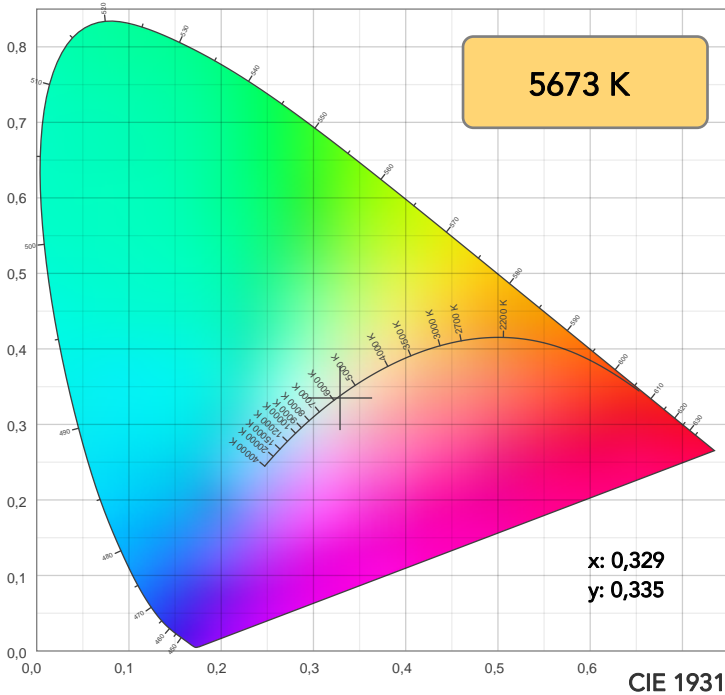

TM30: 90,9

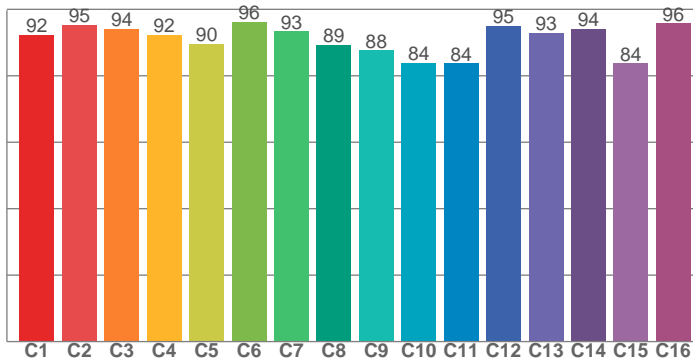

CRI: 96,8 (R1-R8)

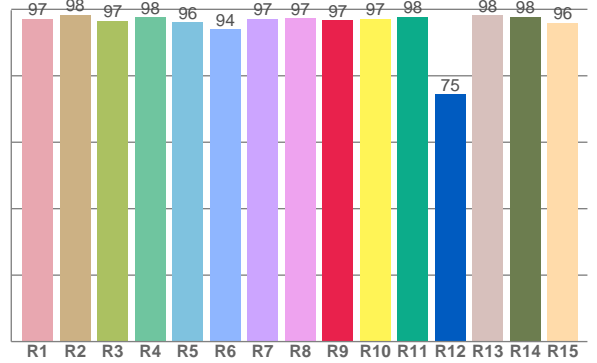

CRI R values, only R1-R8 are used to calculate final CRI value

R1	R2	R3	R4	R5	R6	R7	R8	R9	R10	R11	R12	R13	R14	R15
97,1	98,4	96,6	97,5	96,1	94,0	97,1	97,3	96,7	97,1	97,7	74,5	98,2	97,8	96,0

TM30 C values, 16 binned values out of total of 99 C values

C1	C2	C3	C4	C5	C6	C7	C8	C9	C10	C11	C12	C13	C14	C15	C16
92,3	95,4	94,1	92,3	89,7	96,2	93,4	89,4	87,6	83,8	83,7	95,0	93,0	94,1	83,7	95,8

CQS Q values

Q1	Q2	Q3	Q4	Q5	Q6	Q7	Q8	Q9	Q10	Q11	Q12	Q13	Q14	Q15
94,2	99,4	87,5	85,3	90,3	94,1	97,3	98,1	97,1	95,8	94,5	94,9	95,8	97,1	96,3

CQS: 93,3

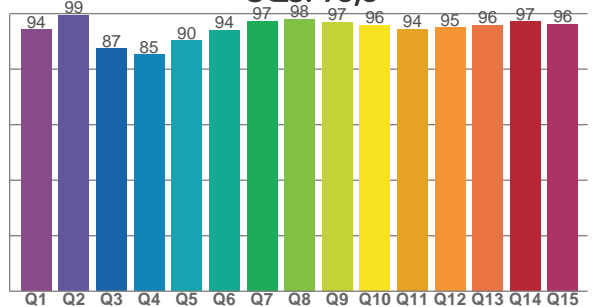

COLOR PARAMETERS

Color temperature	Color rendering index	Red component	Color fidelity	Color gamut	Color quality scale	Television lighting index	Color coordinate cie 1931	Color coordinate cie 1931	Color deviation from black body
CCT	CRI	CRI R9	TM30 Rf	TM30 Rg	CQS	TLCI	x	y	Δuv
5673 K	96,8	96,7	90,9	99,8	93,3	97	0,329	0,335	-0,0048

# TM30 DETAILS

**Rf 90,9**  
Fidelity index Rf

**Rg 99,8**  
Gammut index

Hue Bin	R <sub>f</sub>	Graphic shifts (%)	
		Chroma	Hue
1	92	-1%	1%
2	95	0%	1%
3	94	0%	1%
4	92	-2%	0%
5	90	-4%	0%
6	96	-1%	0%
7	93	-3%	2%
8	89	-3%	5%
9	88	-2%	10%
10	84	0%	9%
11	84	4%	8%
12	95	3%	1%
13	93	4%	-1%
14	94	1%	-1%
15	84	8%	-9%
16	96	-1%	0%

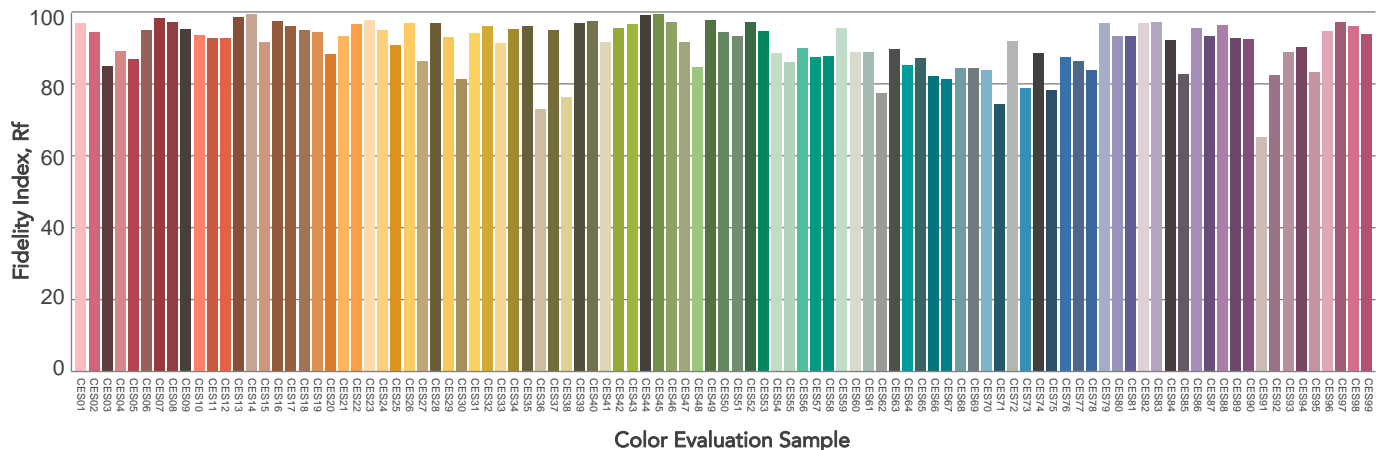
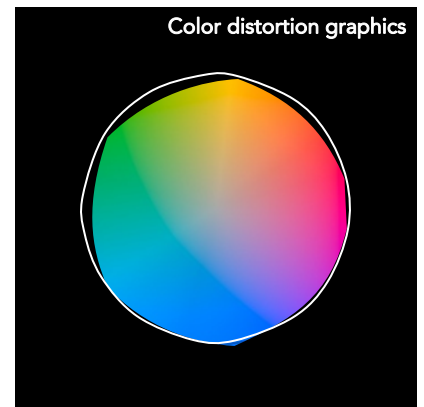
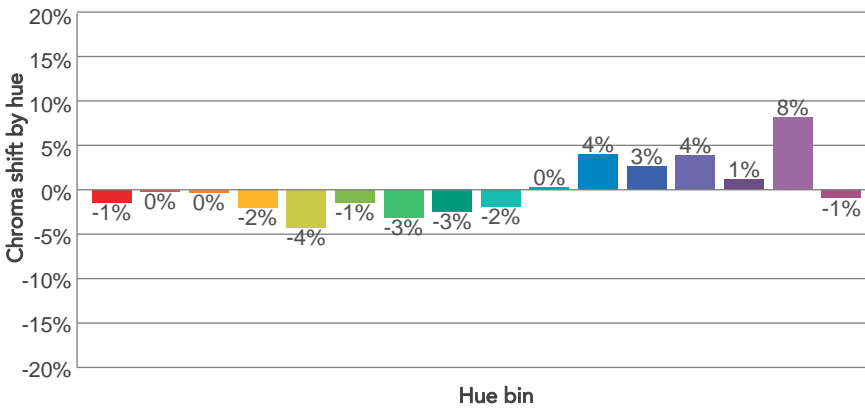
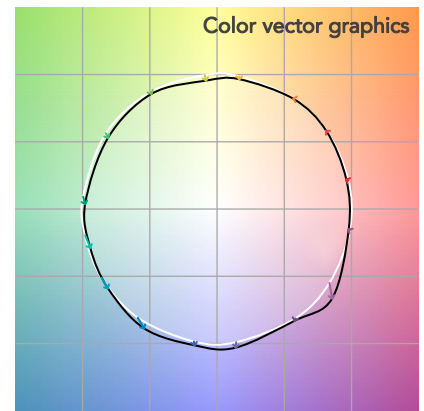
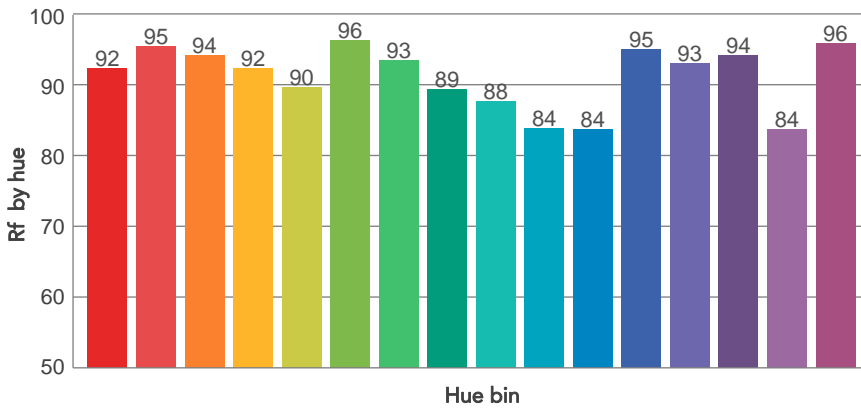
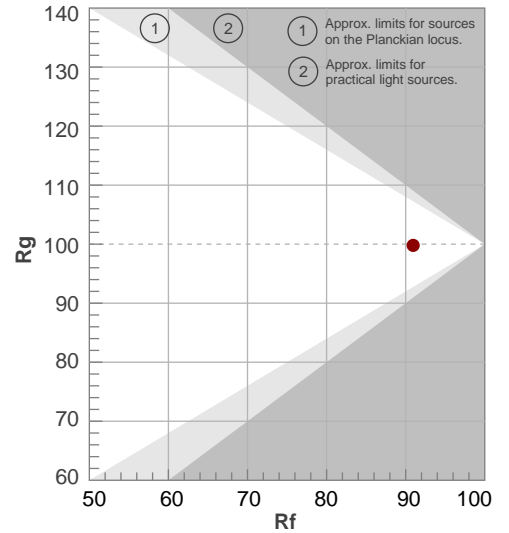

# BEAM DETAILS



Beam angle 50%	Field angle 10%	Cut off angle 2,5%	Intensity ratio in 120° cone	Intensity ratio in 90° cone
15,7°	18,4°	19,3°	100,0%	100,0%

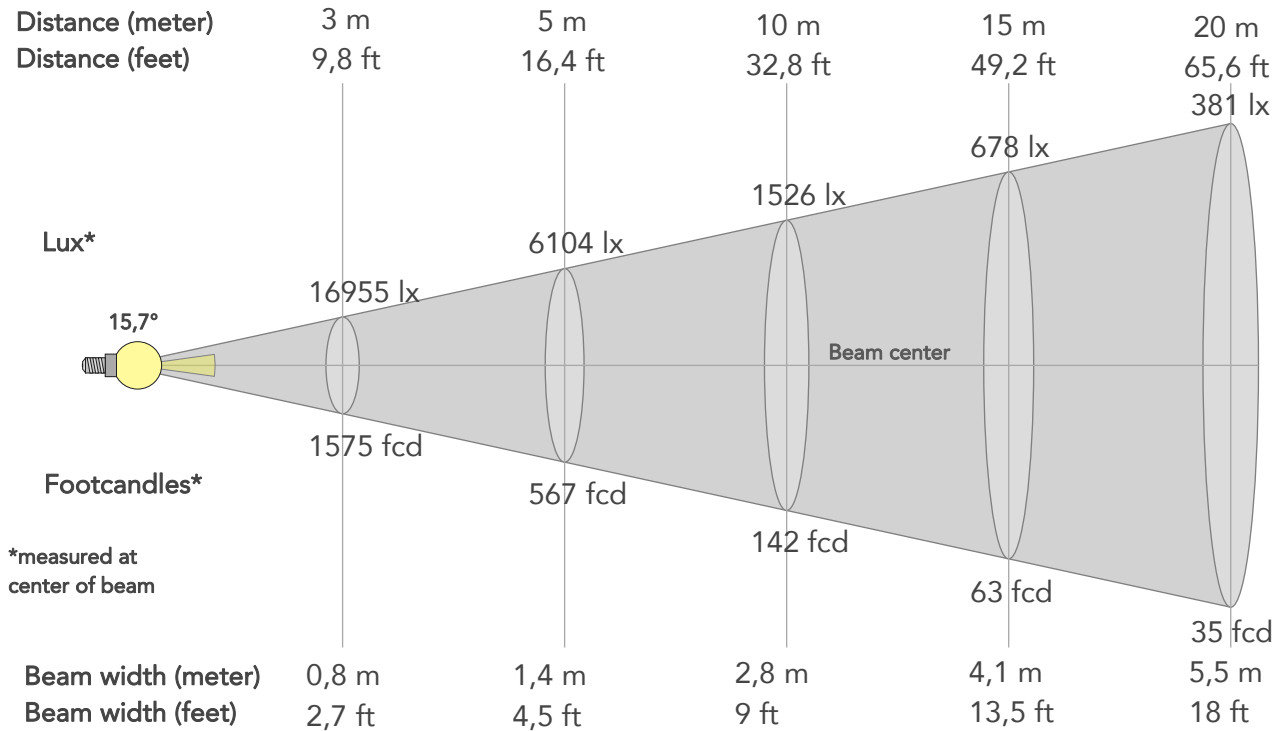

## BEAM INTENSITIES AND WIDTHS

Distance	1m	2m	3m	4m	5m	7,5m	10m	15m	20m	25m	30m	40m	50m
Distance	3,3ft	6,6ft	9,8ft	13,1ft	16,4ft	24,6ft	32,8ft	49,2ft	65,6ft	82ft	98,4ft	131,2ft	164ft
Lux	152591lx	38148lx	16955lx	9537lx	6104lx	2713lx	1526lx	678lx	381lx	244lx	170lx	95lx	61lx
Footcand.	14176fcd	3544fcd	1575fcd	886fcd	567fcd	252fcd	142fcd	63fcd	35fcd	23fcd	16fcd	9fcd	6fcd
Beam wid.	0,3m	0,6m	0,8m	1,1m	1,4m	2,1m	2,8m	4,1m	5,5m	6,9m	8,3m	11m	13,8m
Beam wid.	0,9ft	1,8ft	2,7ft	3,6ft	4,5ft	6,8ft	9ft	13,5ft	18ft	22,6ft	27,1ft	36,1ft	45,1ft

## LINEAR DISTRIBUTION DIAGRAM

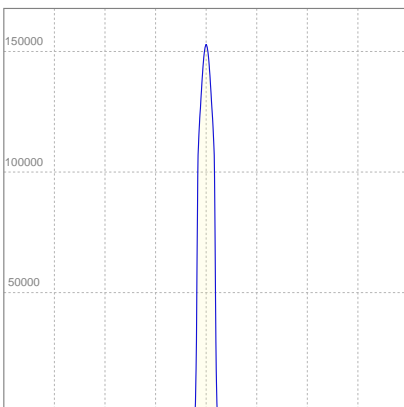

## ELECTRICAL SPECIFICATIONS

Input voltage	Input current	Input power	Effeciency
223V	1,22A	262,7W	31lm/W

Power Fc
0,97

## ISO CANDELA DIAGRAM

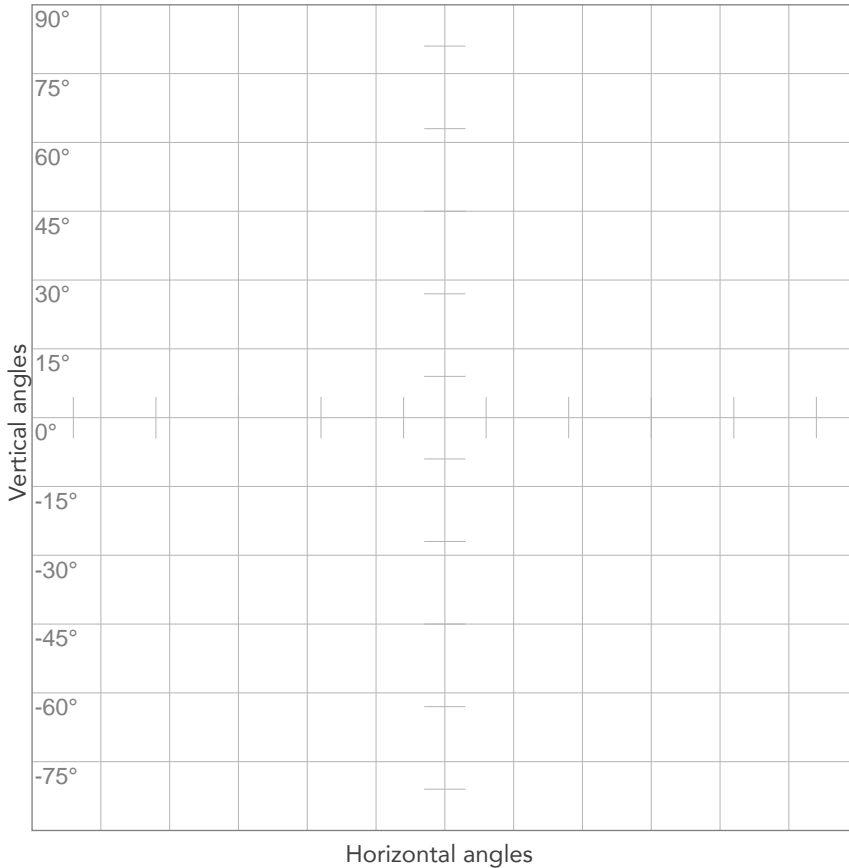

10%	15259 cd
20%	30518 cd
30%	45777 cd
40%	61037 cd
50%	76296 cd
60%	91555 cd
70%	106814 cd
80%	122073 cd

Conditions:  
 Number of c-planes: 2  
 Candela at center: 152591 cd

## ISO LUX DIAGRAM

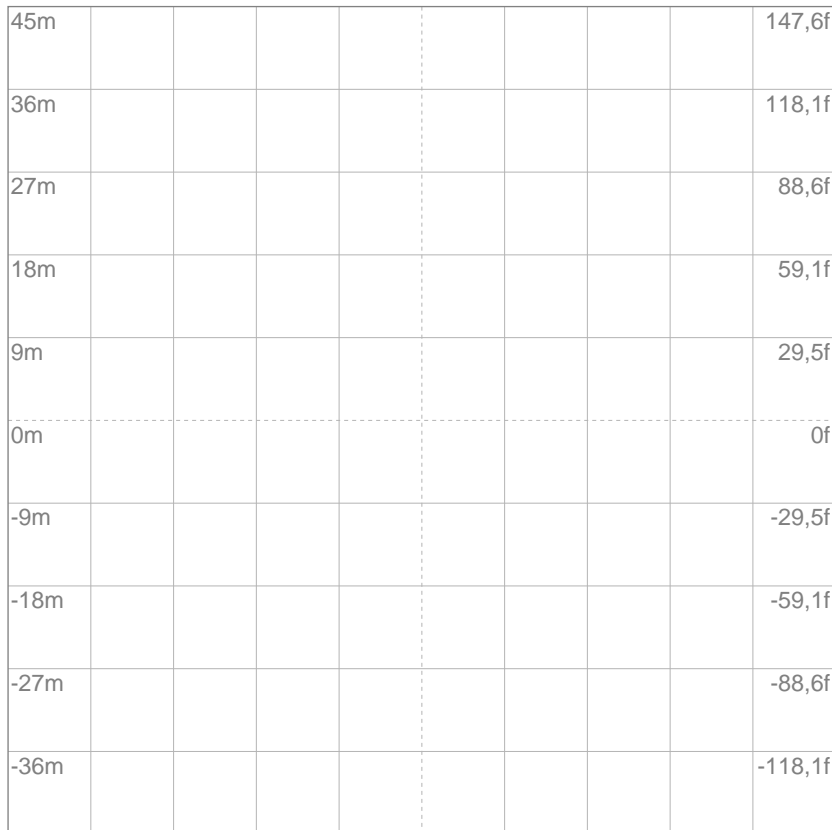

Mounting height: 10 meters (33 feet)

3%	45,8 lx
5%	76,3 lx
10%	153 lx
30%	458 lx
50%	763 lx

Conditions:  
 Number of c-planes: 2  
 Lux at center: 1526 lx

*Lux distribution on a surface when lamp is mounted at 10 meters from the surface.*



Total lumen output:

8527 lm

Peak candela output:

30690 cd

Light quality:

CRI: 96,7

Color temperature:

5698 K

**PRODUCT NAME:**

ECLFWDY

**MEASURAMENT CONDITIONS:**

Beam angle:

PRL25-50 Max Zoom

Target:

Cold White

Operator:

Paolo Carvone

Date and time:

17/11/2020 14:44:18

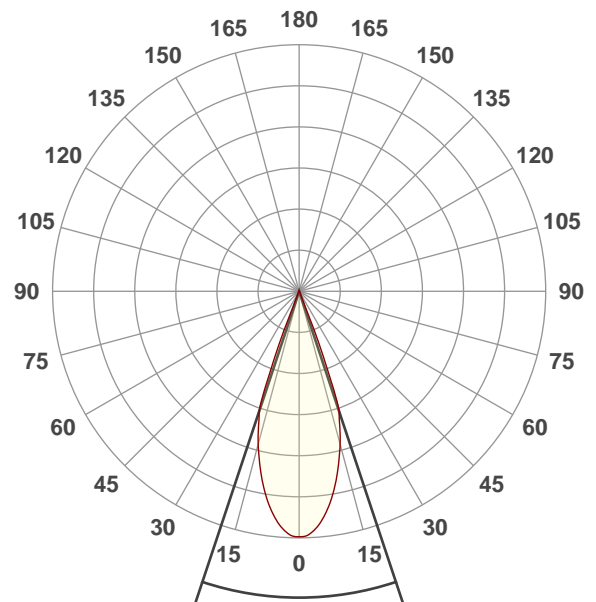

Beam angle 50%: 36,8°

Field angle 10%: 43,8°

Cut off angle 2.5%: 45,1°

Spectra

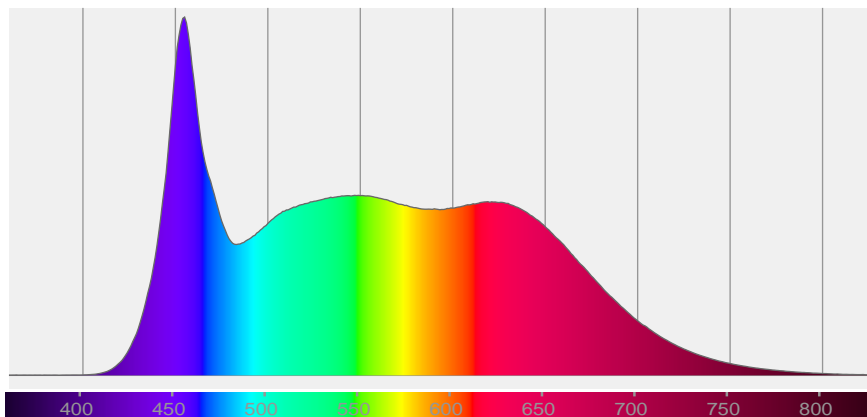

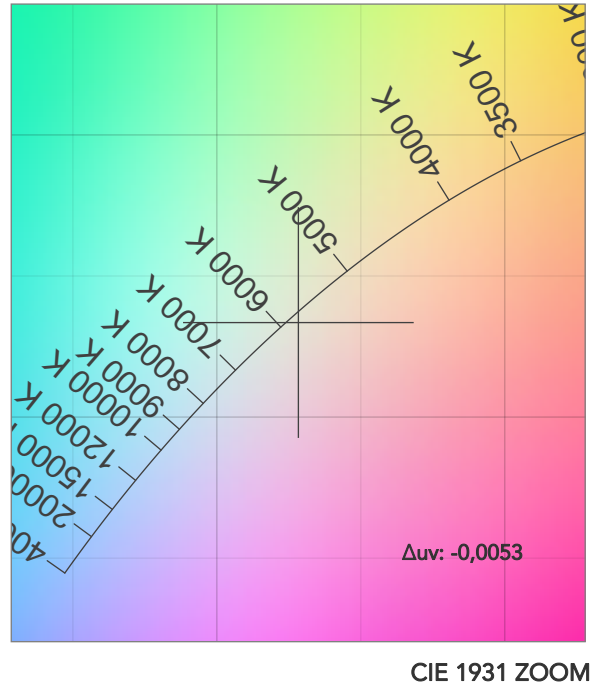
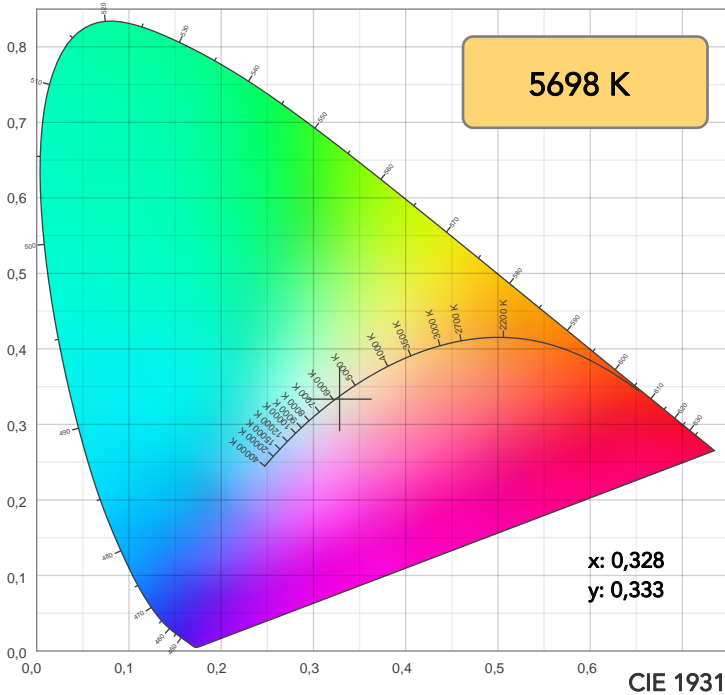

TM30: 91,0

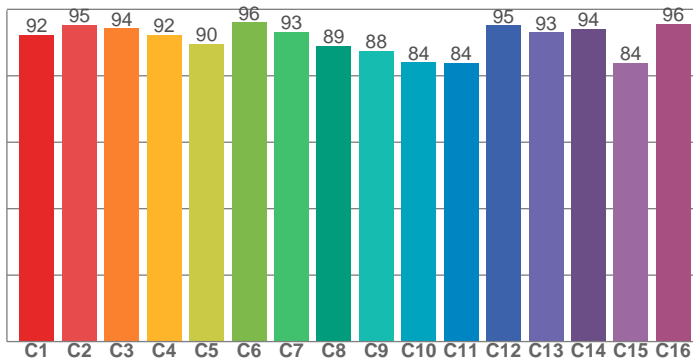

CRI: 96,7 (R1-R8)

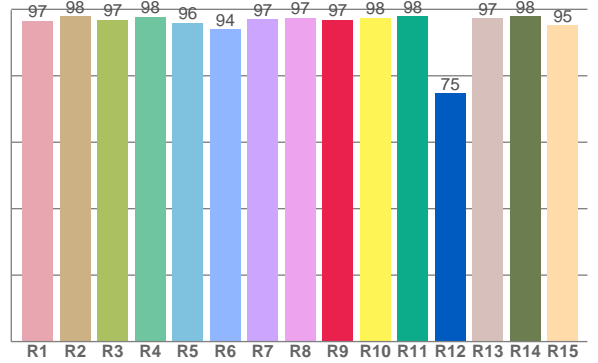

CRI R values, only R1-R8 are used to calculate final CRI value

R1	R2	R3	R4	R5	R6	R7	R8	R9	R10	R11	R12	R13	R14	R15
96,6	97,9	96,8	97,8	96,0	94,0	97,1	97,5	96,9	97,5	97,9	74,8	97,4	97,9	95,2

TM30 C values, 16 binned values out of total of 99 C values

C1	C2	C3	C4	C5	C6	C7	C8	C9	C10	C11	C12	C13	C14	C15	C16
92,3	95,3	94,2	92,3	89,6	96,1	93,3	89,1	87,5	84,0	83,9	95,2	93,0	94,2	83,8	95,6

CQS Q values

Q1	Q2	Q3	Q4	Q5	Q6	Q7	Q8	Q9	Q10	Q11	Q12	Q13	Q14	Q15
94,2	99,4	87,7	85,6	90,5	94,5	97,6	98,5	97,0	96,1	94,8	95,2	95,9	97,2	96,4

CQS: 93,5

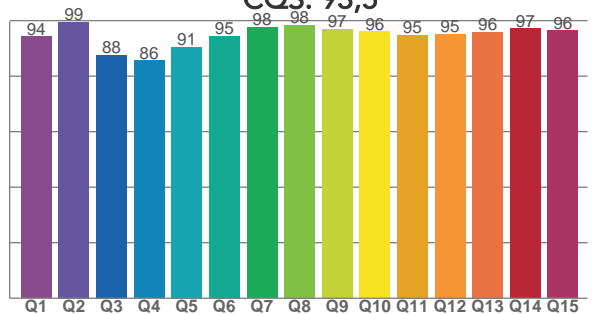

COLOR PARAMETERS

Color temperature	Color rendering index	Red component	Color fidelity	Color gamut	Color quality scale	Television lighting index	Color coordinate cie 1931	Color coordinate cie 1931	Color deviation from black body
CCT	CRI	CRI R9	TM30 Rf	TM30 Rg	CQS	TLCI	x	y	Δuv
5698 K	96,7	96,9	91,0	100,0	93,5	97	0,328	0,333	-0,0053

# TM30 DETAILS

**Rf 91,0**  
Fidelity index Rf

**Rg 100,0**  
Gammut index

Hue Bin	R <sub>f</sub>	Graphic shifts (%)	
		Chroma	Hue
1	92	-1%	1%
2	95	0%	1%
3	94	0%	1%
4	92	-2%	-1%
5	90	-4%	0%
6	96	-2%	0%
7	93	-3%	2%
8	89	-2%	5%
9	88	-2%	10%
10	84	1%	9%
11	84	4%	8%
12	95	3%	1%
13	93	4%	-1%
14	94	1%	-1%
15	84	8%	-8%
16	96	-1%	1%

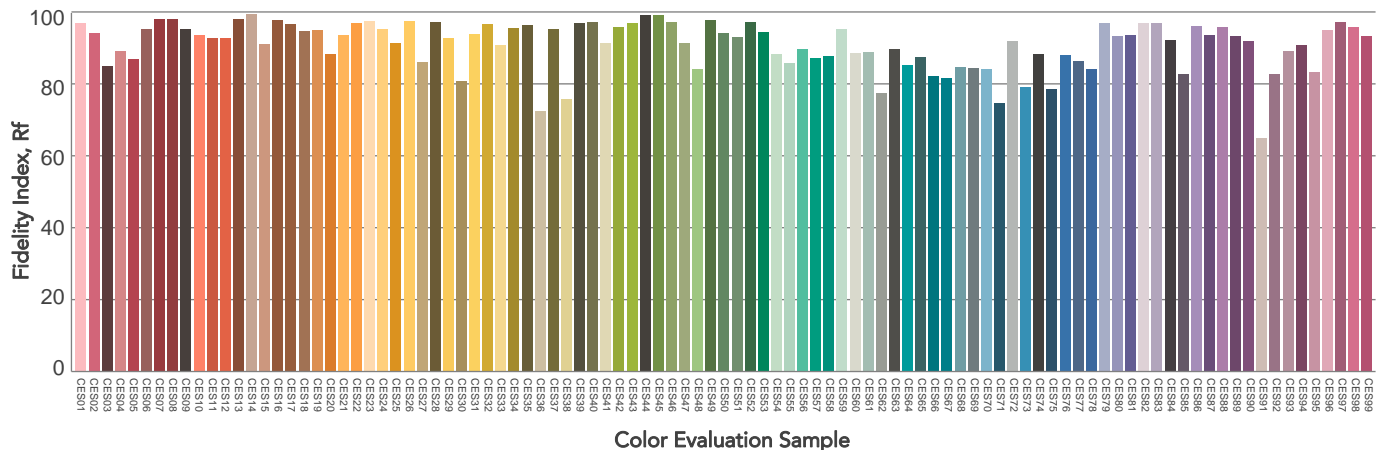
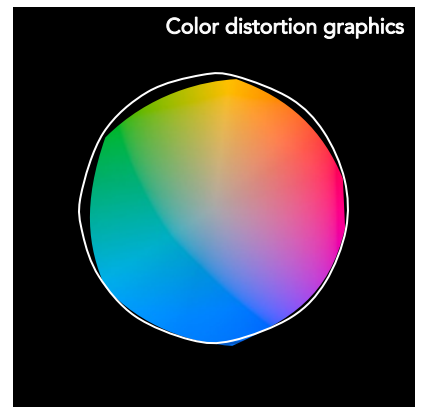
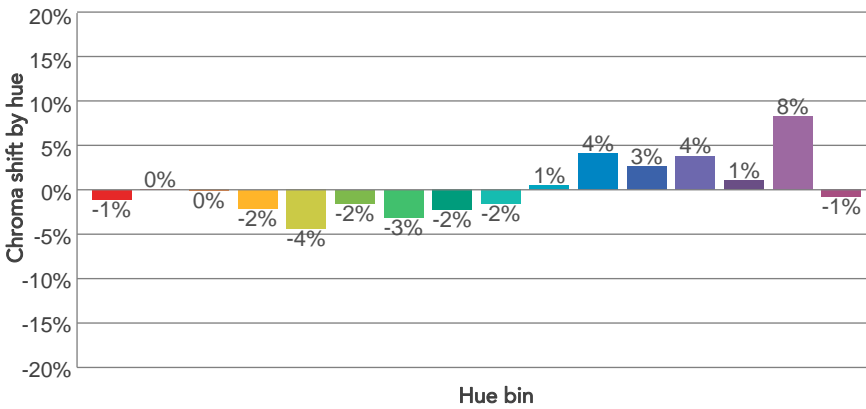
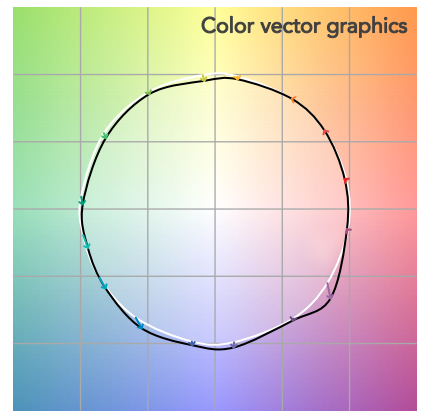
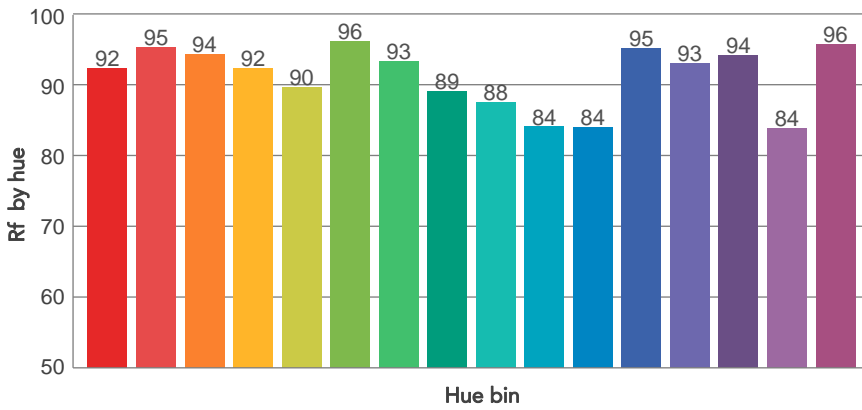
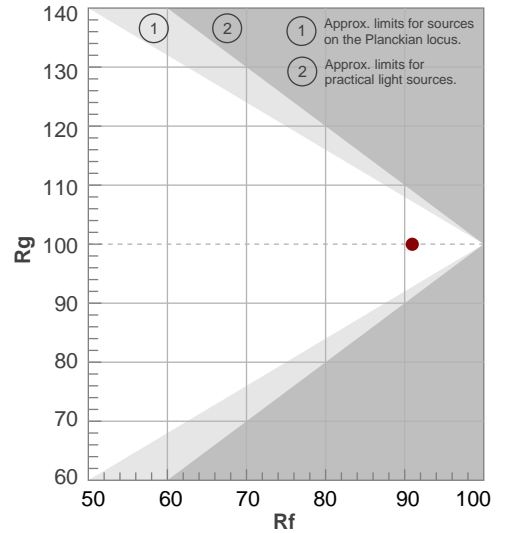



# BEAM DETAILS



Beam angle 50%	Field angle 10%	Cut off angle 2,5%	Intensity ratio in 120° cone	Intensity ratio in 90° cone
36,8°	43,8°	45,1°	100,0%	100,0%

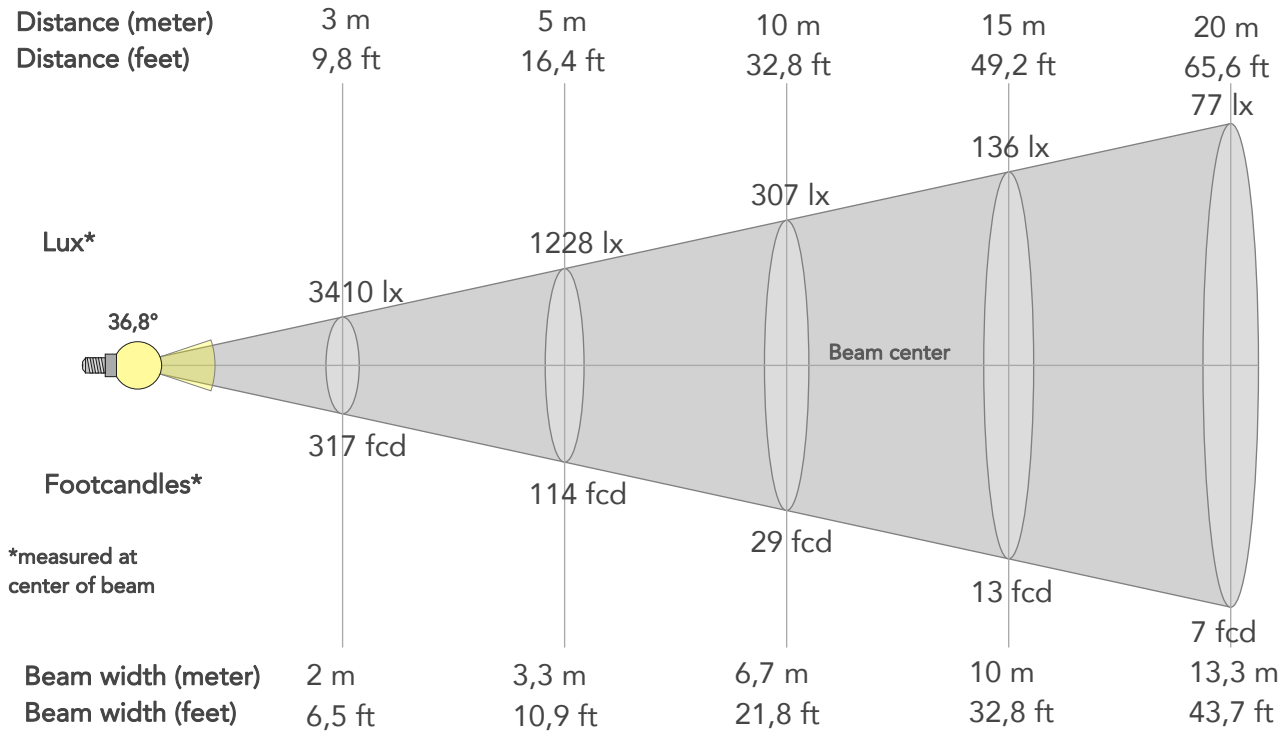

## BEAM INTENSITIES AND WIDTHS

Distance	1m	2m	3m	4m	5m	7,5m	10m	15m	20m	25m	30m	40m	50m
Distance	3,3ft	6,6ft	9,8ft	13,1ft	16,4ft	24,6ft	32,8ft	49,2ft	65,6ft	82ft	98,4ft	131,2ft	164ft
Lux	30690lx	7673lx	3410lx	1918lx	1228lx	546lx	307lx	136lx	77lx	49lx	34lx	19lx	12lx
Footcand.	2851fcd	713fcd	317fcd	178fcd	114fcd	51fcd	29fcd	13fcd	7fcd	5fcd	3fcd	2fcd	1fcd
Beam wid.	0,7m	1,3m	2m	2,7m	3,3m	5m	6,7m	10m	13,3m	16,6m	20m	26,6m	33,3m
Beam wid.	2,2ft	4,4ft	6,5ft	8,7ft	10,9ft	16,4ft	21,8ft	32,8ft	43,7ft	54,6ft	65,5ft	87,4ft	109,2ft

## LINEAR DISTRIBUTION DIAGRAM

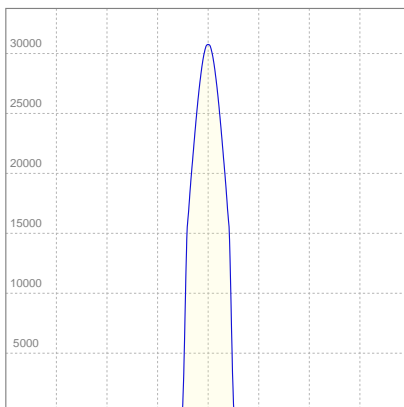

## ELECTRICAL SPECIFICATIONS

Input voltage	Input current	Input power	Effeciency
223V	1,22A	262,5W	32lm/W

Power Fc
0,97

## ISO CANDELA DIAGRAM

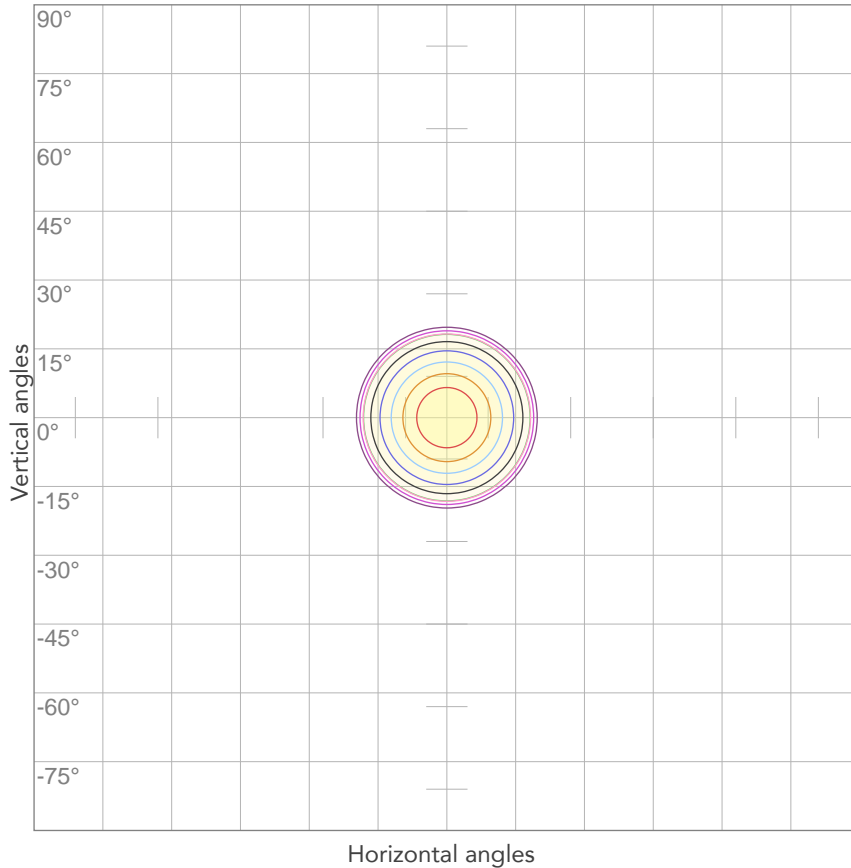

10%	3069 cd
20%	6138 cd
30%	9207 cd
40%	12276 cd
50%	15345 cd
60%	18414 cd
70%	21483 cd
80%	24552 cd

**Conditions:**

Number of c-planes: 2

Candela at center: 30690 cd

## ISO LUX DIAGRAM

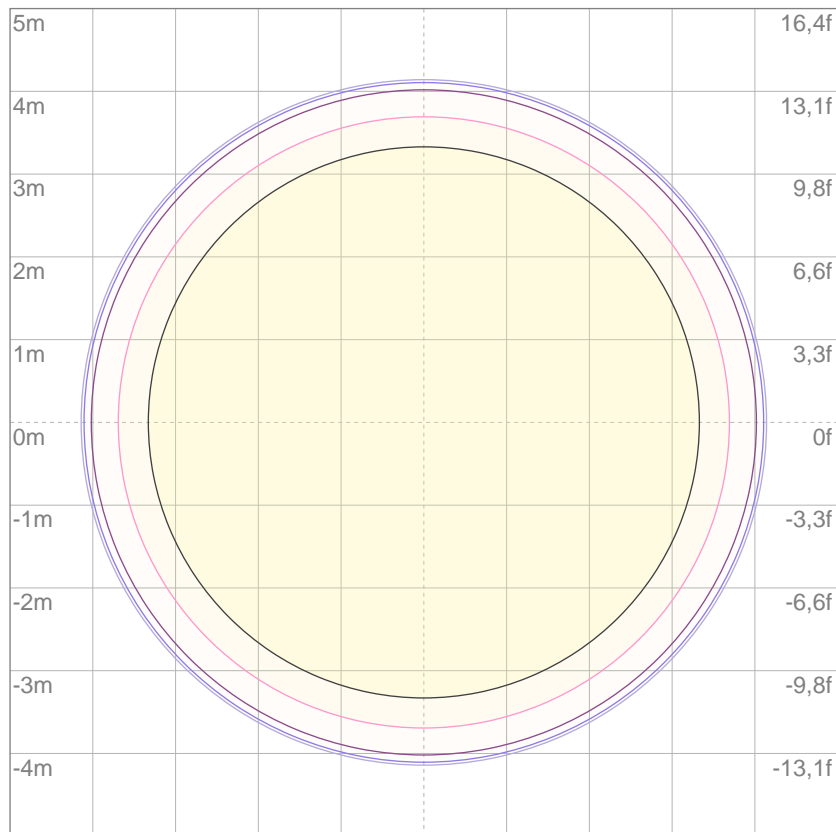

3%	9,21 lx
5%	15,3 lx
10%	30,7 lx
30%	92,1 lx
50%	153 lx

**Conditions:**

Number of c-planes: 2

Lux at center: 307 lx

*Lux distribution on a surface when lamp is mounted at 10 meters from the surface.*

Mounting height: 10 meters (33 feet)



Total lumen output:

7781 lm

Peak candela output:

81342 cd

Light quality:

CRI: 96,7

Color temperature:

5641 K

**PRODUCT NAME:**

ECLFWDY

**MEASURAMENT CONDITIONS:**

Beam angle:

PRL25-50 Min Zoom

Target:

Cold White

Operator:

Paolo Carvone

Date and time:

17/11/2020 14:40:16

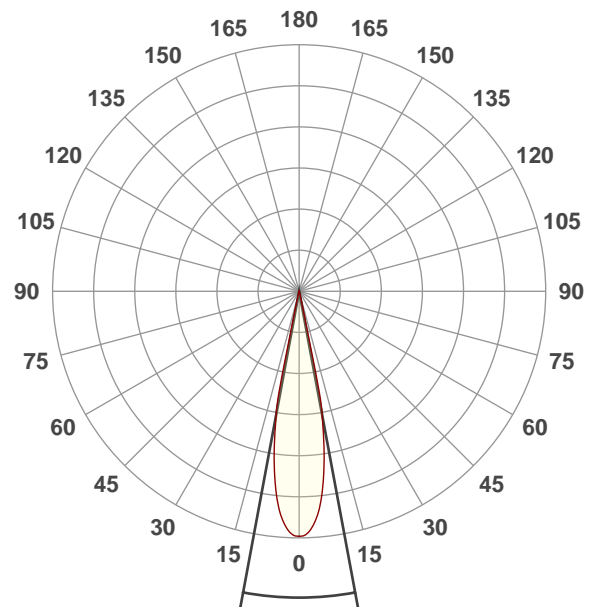

Beam angle 50%: 21,1°

Field angle 10%: 24,8°

Cut off angle 2.5%: 26,7°

Spectra

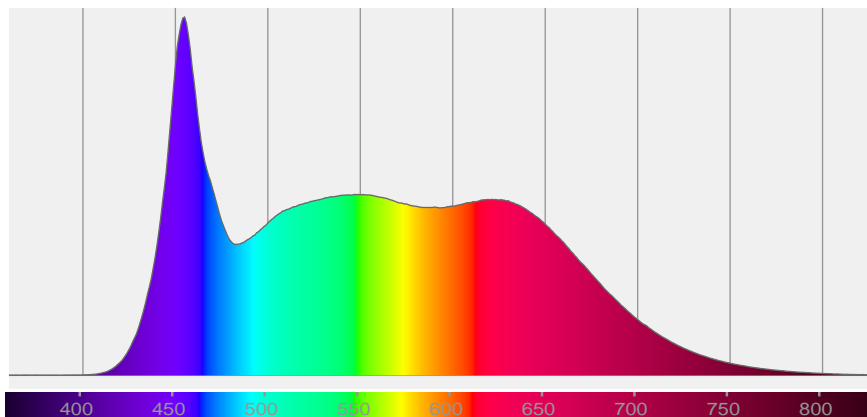

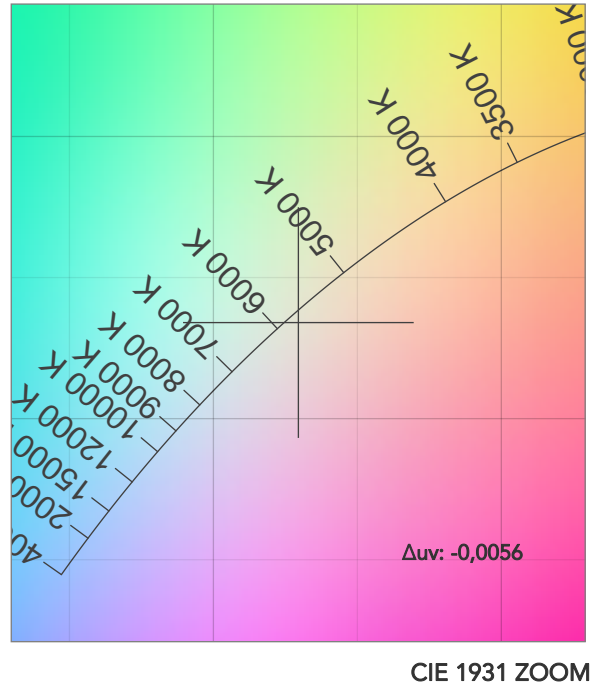
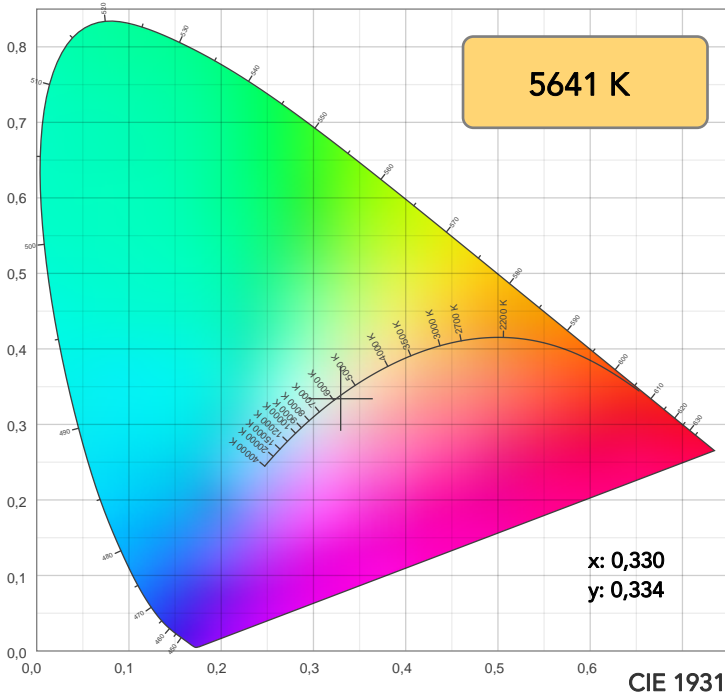

TM30: 91,0

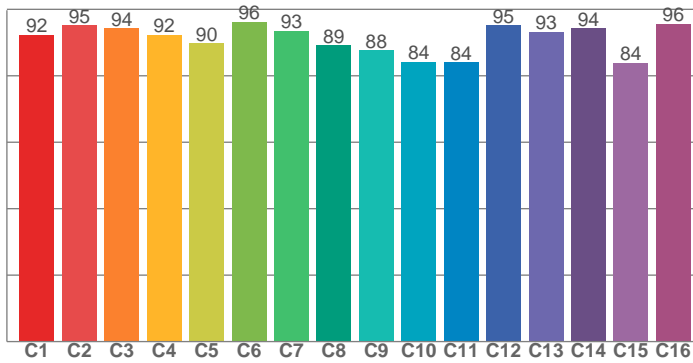

CRI: 96,7 (R1-R8)

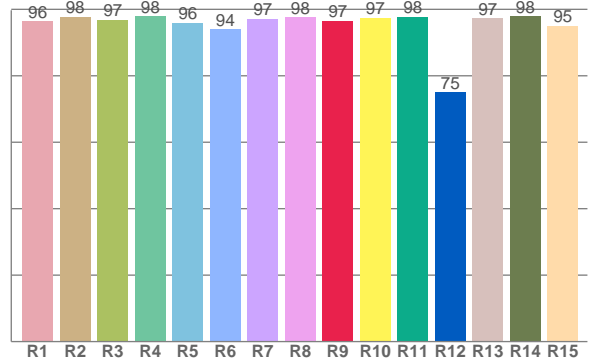

CRI R values, only R1-R8 are used to calculate final CRI value

R1	R2	R3	R4	R5	R6	R7	R8	R9	R10	R11	R12	R13	R14	R15
96,5	97,8	96,8	97,9	96,0	93,9	97,2	97,6	96,6	97,4	97,8	75,1	97,2	97,9	95,1

TM30 C values, 16 binned values out of total of 99 C values

C1	C2	C3	C4	C5	C6	C7	C8	C9	C10	C11	C12	C13	C14	C15	C16
92,4	95,2	94,2	92,4	89,7	96,2	93,4	89,2	87,7	84,2	84,0	95,1	93,1	94,2	84,0	95,7

CQS Q values

Q1	Q2	Q3	Q4	Q5	Q6	Q7	Q8	Q9	Q10	Q11	Q12	Q13	Q14	Q15
94,4	99,5	87,6	85,6	90,7	94,7	97,6	98,5	97,0	96,0	94,7	95,1	95,8	97,2	96,5

CQS: 93,5

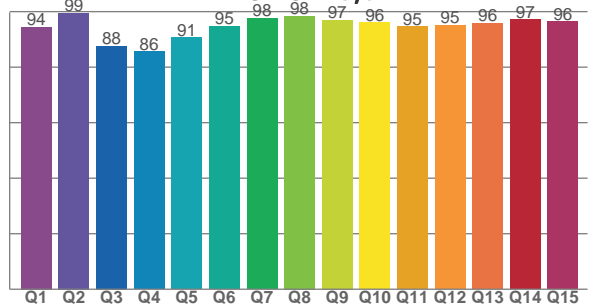

COLOR PARAMETERS

Color temperature	Color rendering index	Red component	Color fidelity	Color gamut	Color quality scale	Television lighting index	Color coordinate cie 1931	Color coordinate cie 1931	Color deviation from black body
CCT	CRI	CRI R9	TM30 Rf	TM30 Rg	CQS	TLCI	x	y	Δuv
5641 K	96,7	96,6	91,0	100,1	93,5	97	0,330	0,334	-0,0056

# TM30 DETAILS

**Rf 91,0**  
Fidelity index Rf

**Rg 100,1**  
Gammut index

Hue Bin	R <sub>f</sub>	Graphic shifts (%)	
		Chroma	Hue
1	92	-1%	1%
2	95	0%	1%
3	94	0%	1%
4	92	-2%	-1%
5	90	-4%	0%
6	96	-1%	0%
7	93	-3%	2%
8	89	-2%	5%
9	88	-2%	10%
10	84	1%	9%
11	84	4%	8%
12	95	3%	1%
13	93	4%	-1%
14	94	1%	-1%
15	84	8%	-8%
16	96	-1%	1%

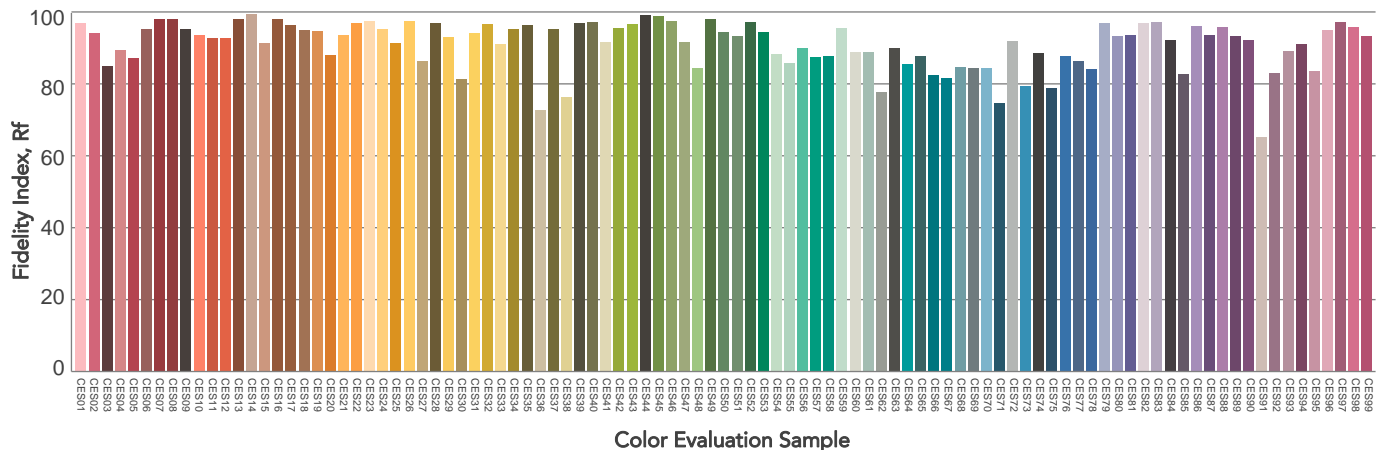
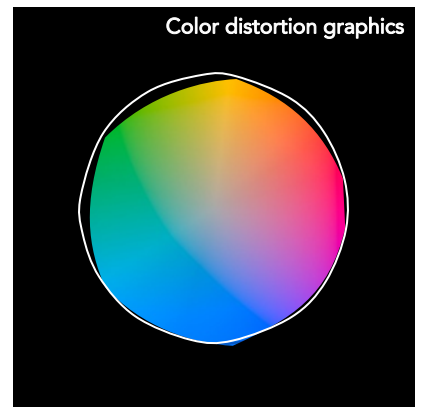
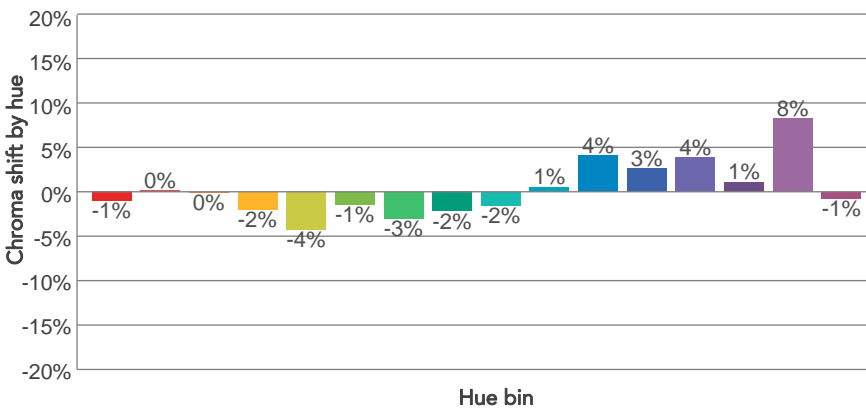
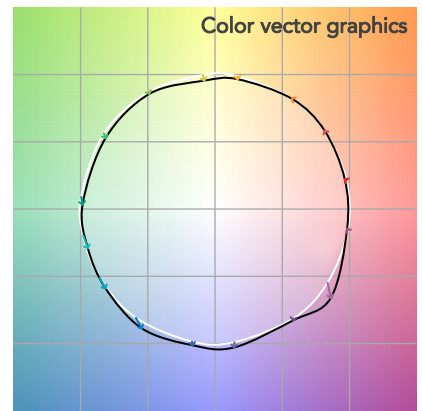
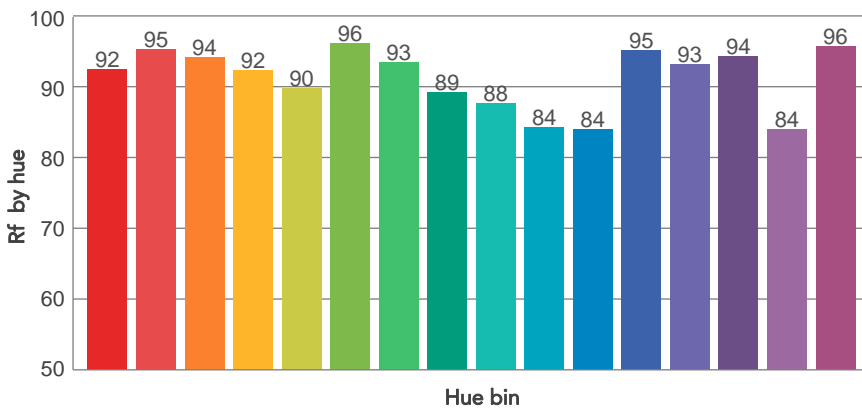
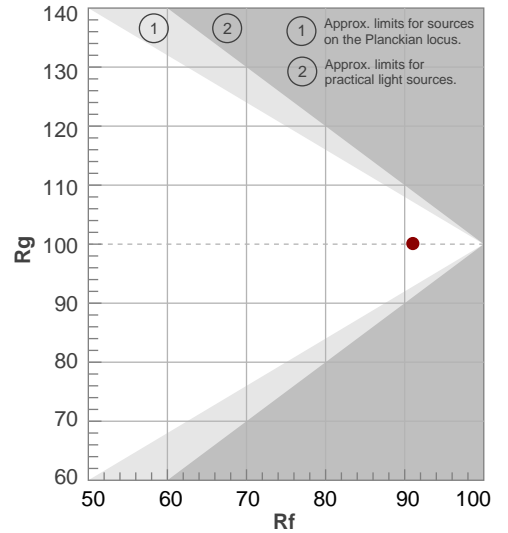

# BEAM DETAILS



Beam angle 50%	Field angle 10%	Cut off angle 2,5%	Intensity ratio in 120° cone	Intensity ratio in 90° cone
21,1°	24,8°	26,7°	100,0%	100,0%

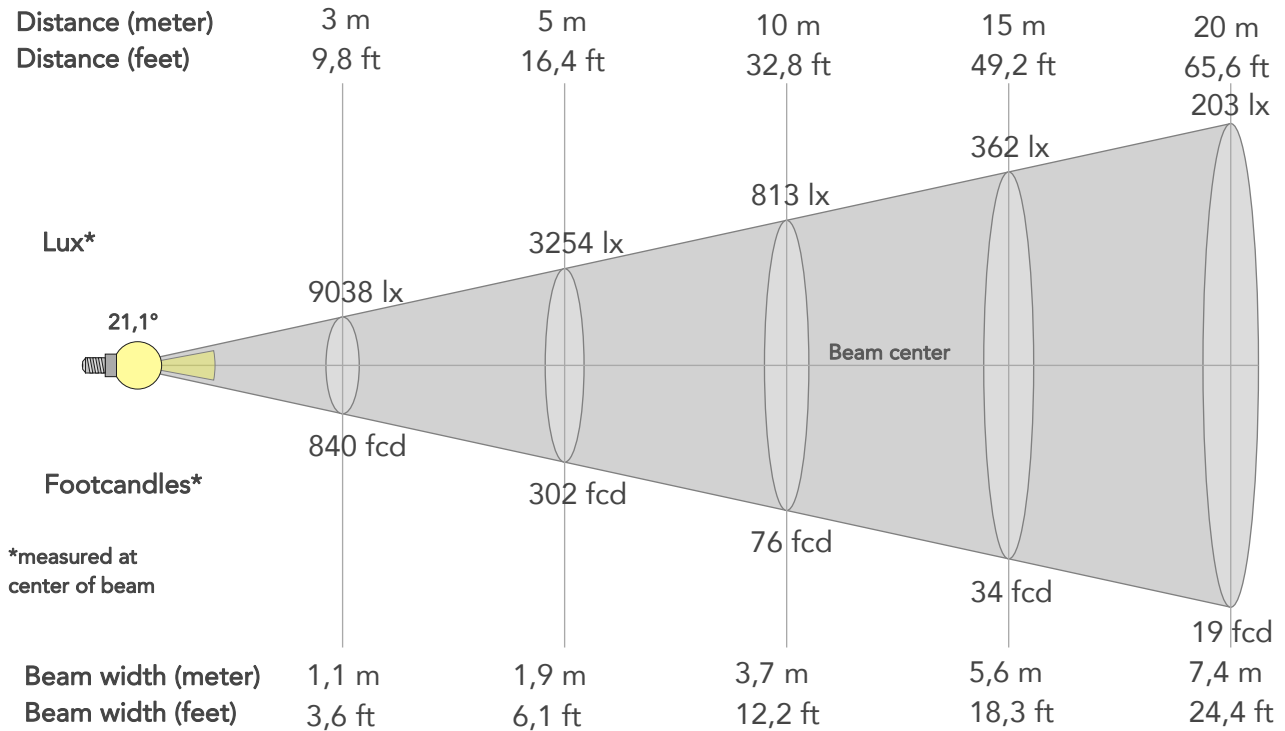

## BEAM INTENSITIES AND WIDTHS

Distance	1m	2m	3m	4m	5m	7,5m	10m	15m	20m	25m	30m	40m	50m
Distance	3,3ft	6,6ft	9,8ft	13,1ft	16,4ft	24,6ft	32,8ft	49,2ft	65,6ft	82ft	98,4ft	131,2ft	164ft
Lux	81342lx	20335lx	9038lx	5084lx	3254lx	1446lx	813lx	362lx	203lx	130lx	90lx	51lx	33lx
Footcand.	7557fcd	1889fcd	840fcd	472fcd	302fcd	134fcd	76fcd	34fcd	19fcd	12fcd	8fcd	5fcd	3fcd
Beam wid.	0,4m	0,7m	1,1m	1,5m	1,9m	2,8m	3,7m	5,6m	7,4m	9,3m	11,2m	14,9m	18,6m
Beam wid.	1,2ft	2,5ft	3,6ft	4,9ft	6,1ft	9,2ft	12,2ft	18,3ft	24,4ft	30,5ft	36,6ft	48,8ft	61ft

## LINEAR DISTRIBUTION DIAGRAM

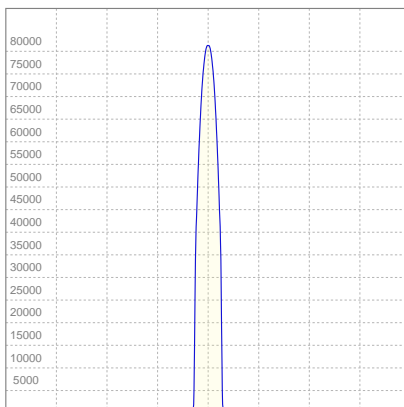

## ELECTRICAL SPECIFICATIONS

Input voltage	Input current	Input power	Effeciency
225V	1,21A	262,6W	30lm/W
Power Fc			
0,97			

## ISO CANDELA DIAGRAM

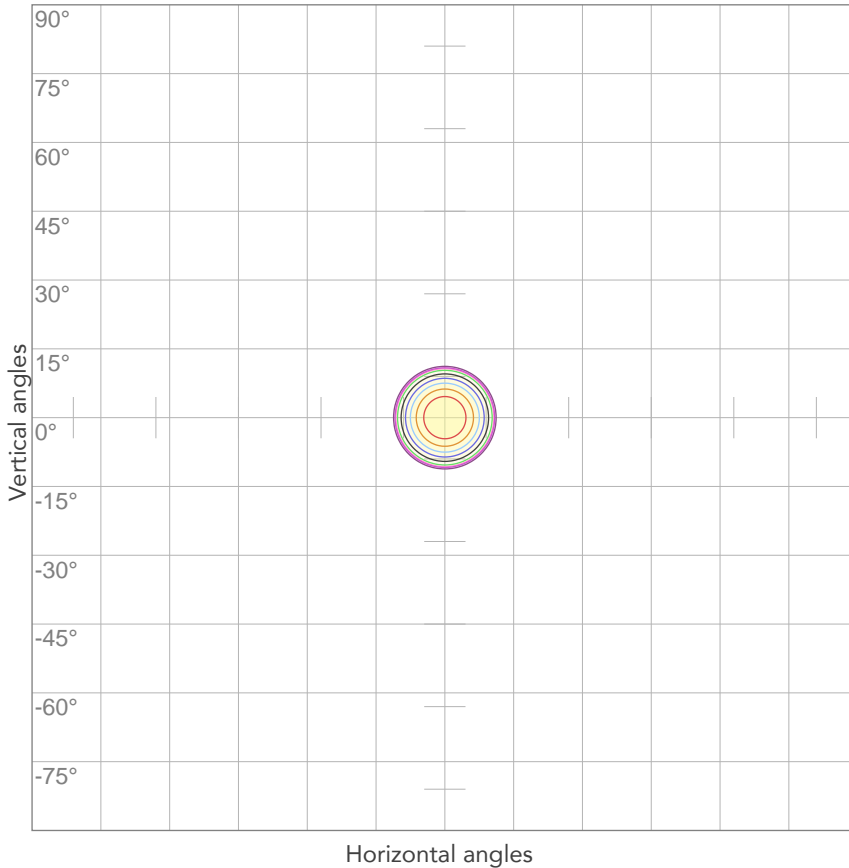

10%	8134 cd
20%	16268 cd
30%	24402 cd
40%	32537 cd
50%	40671 cd
60%	48805 cd
70%	56939 cd
80%	65073 cd

Conditions:

Number of c-planes: 2

Candela at center: 81342 cd

## ISO LUX DIAGRAM

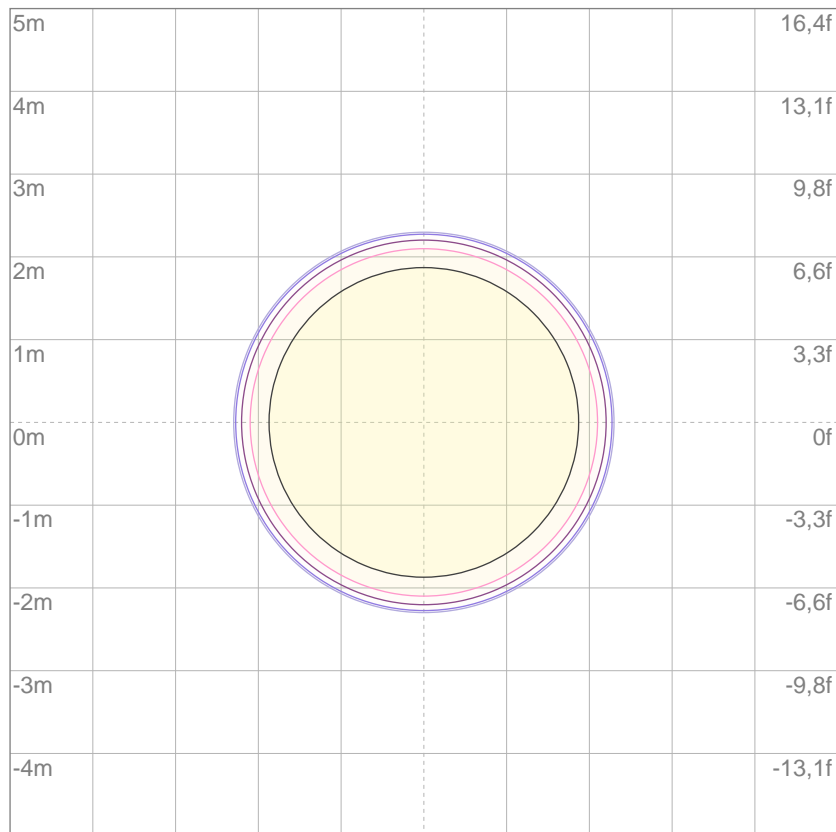

Mounting height: 10 meters (33 feet)

3%	24,4 lx
5%	40,7 lx
10%	81,3 lx
30%	244 lx
50%	407 lx

Conditions:

Number of c-planes: 2

Lux at center: 813 lx

*Lux distribution on a surface when lamp is mounted at 10 meters from the surface.*