

Photometric Test Report



ECLCTPLUS PRL26

High quality six colours full spectrum
ellipsoidal LED

CONTENTS

Table of contents	2
Testing process	3
Color preset Full on	4
Color preset Red	7
Color preset Green	10
Color preset Blue	13
Color temperature 2800K	16
Color temperature 3200K	21
Color temperature 4000K	26
Color temperature 5600K	31
Color temperature 6000K	36

TESTING PROCESS

Prolights has its own optical testing laboratory in order to provide accurate photometric reports for its lighting products. The testing laboratory contains certain variety of precise lighting measurement systems that ensure an optimal reading of all the characteristic parameters of the lighting devices. All measurements are made at a controlled room temperature of 20°C without any external light sources. This photometric report is obtained through the data measured by a high precision measurement system and analyzed by a dedicate software.

Prolights measurement instrument

Prolights measurement instrument is a complete measurement system for any light source. It's equipped with two-axis goniometer, that enables to measure the full 3D distribution field of the light source. This instrument measures the light intensity, the beam angle and the most significative colors parameters, like color temperature, spectral distribution, CRI, CQS, TM-30 with a very high accuracy rate.

Please Note: All measurements are made with light source at operating temperature. Before starting the measurement, the instrument analyzes the process of the light source during the heating phase. The measuring process of all the parameters begins only when the light emission is stable, that is with a variation of less than 0.5% in a 15 minutes time frame.

Prolights measurement software

The software provides user friendly interface for the operator who does the measurements, and it also analyzes and processes all the collected data by the instrument. With this software it is possible to see the measured data in real-time and it is possible to examine all the measured data and graphics afterwards as well. All information is collected in a specific Prolights template, and the software creates also IES and LDT files, which are widely used to transfer the photometric data, and to develop lighting system.

Additionally, the fixtures are rechecked using various hand-held instruments like Sekonic C-700 and Gossen Mavospec Base, this is done to ensure, that the data in the photometric report are as accurate as possible.



Total lumen output:

6681 lm

Peak candela output:

43970 cd

PRODUCT NAME:

ECLCTPLUS

MEASURAMENT CONDITIONS:

Beam angle:

PRL26

Target:

Full On HQ

Operator:

Paolo Carvone

Date and time:

14/07/2020 11:50:56

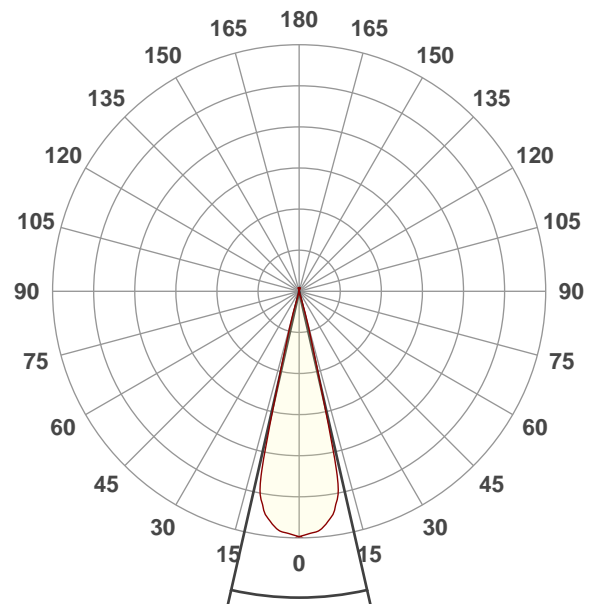

Beam angle 50%: 25,6°

Field angle 10%: 30,5°

Cut off angle 2.5%: 32,2°

Spectra

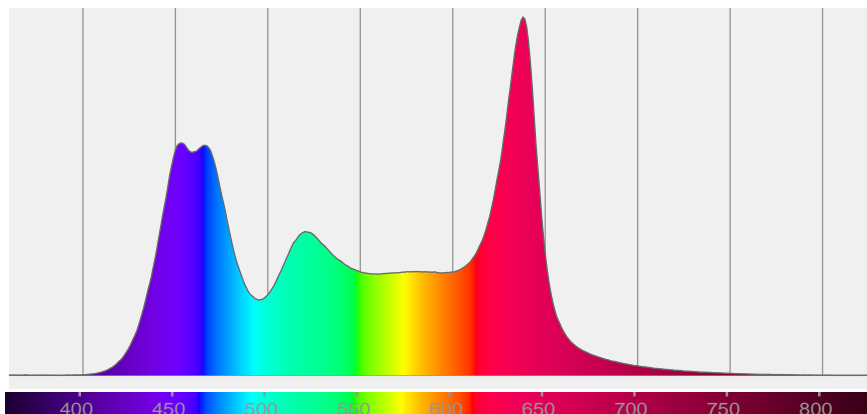

BEAM DETAILS



Beam angle 50%	Field angle 10%	Cut off angle 2,5%	Intensity ratio in 120° cone	Intensity ratio in 90° cone
25,6°	30,5°	32,2°	100,0%	100,0%

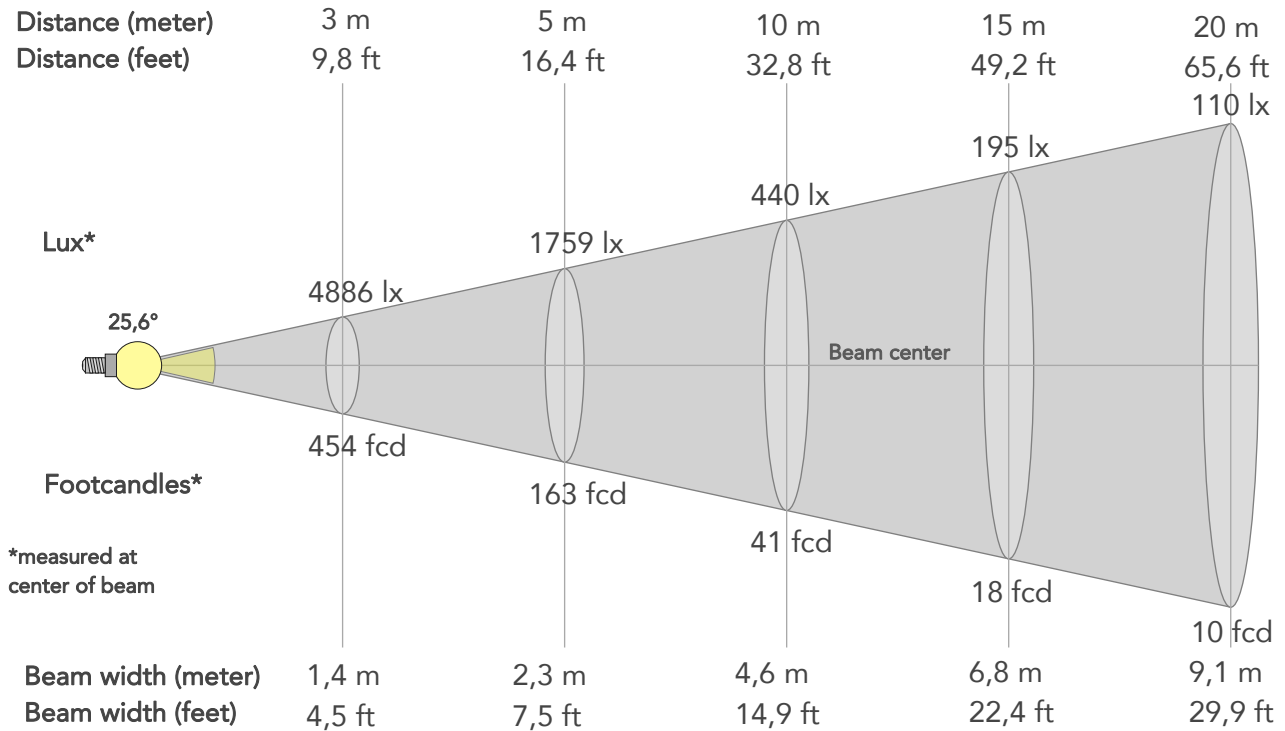

BEAM INTENSITIES AND WIDTHS

Distance	1m	2m	3m	4m	5m	7,5m	10m	15m	20m	25m	30m	40m	50m
Distance	3,3ft	6,6ft	9,8ft	13,1ft	16,4ft	24,6ft	32,8ft	49,2ft	65,6ft	82ft	98,4ft	131,2ft	164ft
Lux	43970lx	10992lx	4886lx	2748lx	1759lx	782lx	440lx	195lx	110lx	70lx	49lx	27lx	18lx
Footcand.	4085fcd	1021fcd	454fcd	255fcd	163fcd	73fcd	41fcd	18fcd	10fcd	7fcd	5fcd	3fcd	2fcd
Beam wid.	0,5m	0,9m	1,4m	1,8m	2,3m	3,4m	4,6m	6,8m	9,1m	11,4m	13,7m	18,2m	22,8m
Beam wid.	1,5ft	3ft	4,5ft	6ft	7,5ft	11,2ft	14,9ft	22,4ft	29,9ft	37,3ft	44,8ft	59,7ft	74,6ft

LINEAR DISTRIBUTION DIAGRAM

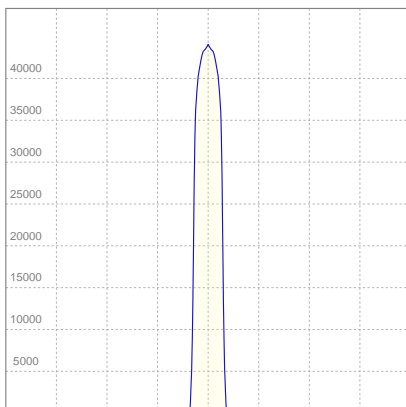

ELECTRICAL SPECIFICATIONS

Input voltage	Input current	Input power	Effeciency
226V	1,23A	264,7W	25lm/W

Power FC
0,96

ISO CANDELA DIAGRAM

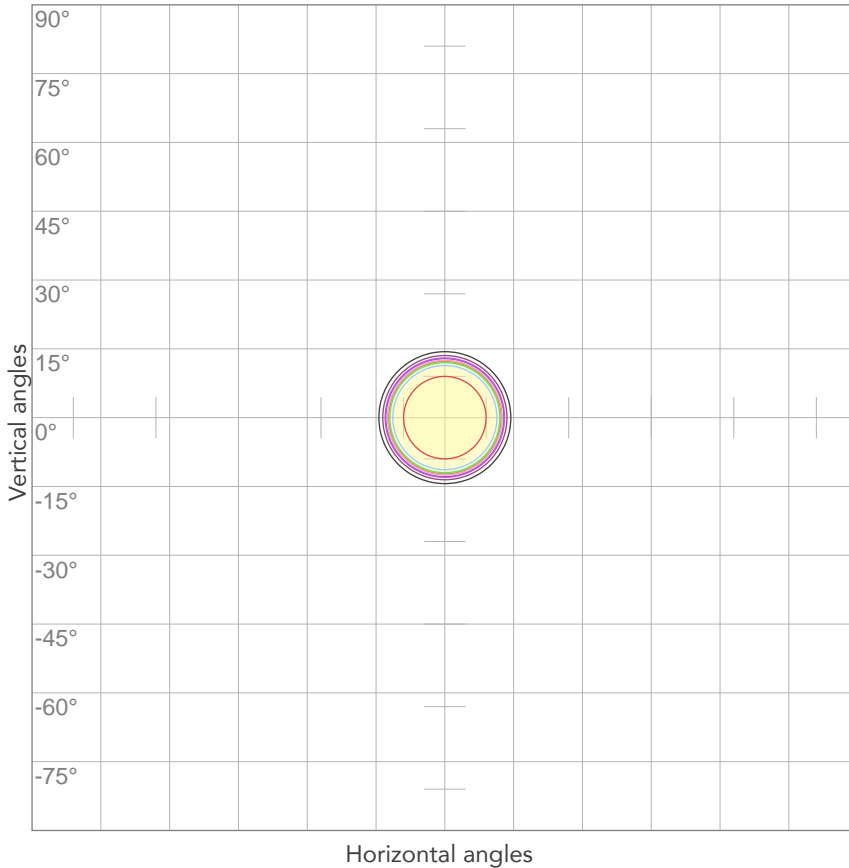

10%	4397 cd
20%	8794 cd
30%	13191 cd
40%	17588 cd
50%	21985 cd
60%	26382 cd
70%	30779 cd
80%	35176 cd

Conditions:

Number of c-planes: 2

Candela at center: 43970 cd

ISO LUX DIAGRAM

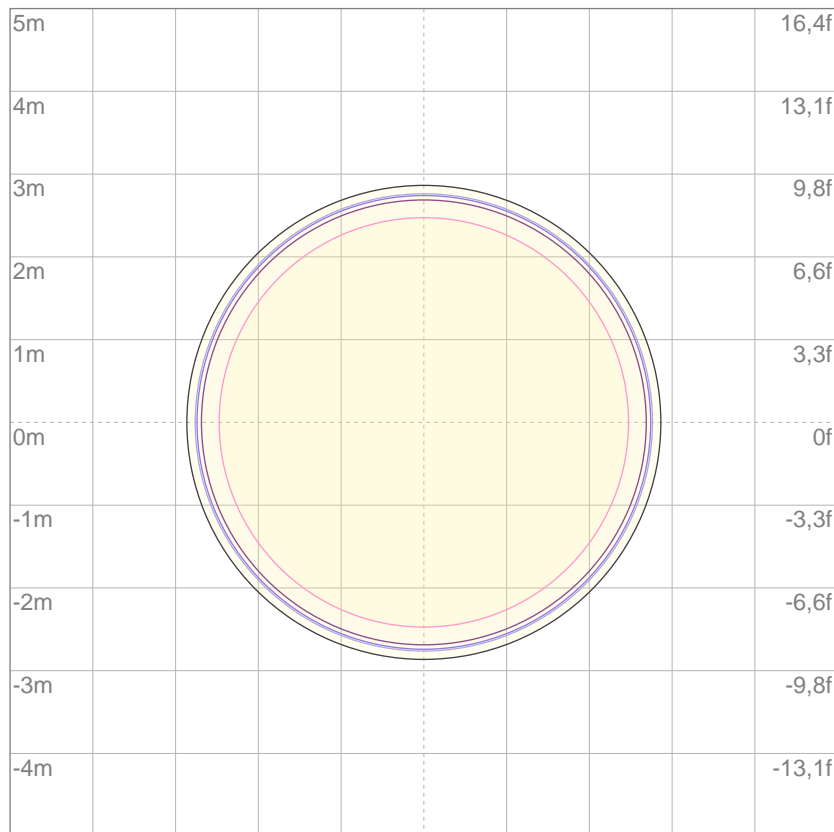

3%	13,2 lx
5%	22,0 lx
10%	44,0 lx
30%	132 lx
50%	220 lx

Conditions:

Number of c-planes: 2

Lux at center: 440 lx

Lux distribution on a surface when lamp is mounted at 10 meters from the surface.

Mounting height: 10 meters (33 feet)



Total lumen output:

1039 lm

Peak candela output:

6543 cd

PRODUCT NAME:

ECLCTPLUS

MEASURAMENT CONDITIONS:

Beam angle:

PRL26

Target:

Red HQ

Operator:

Paolo Carvone

Date and time:

14/07/2020 11:34:29

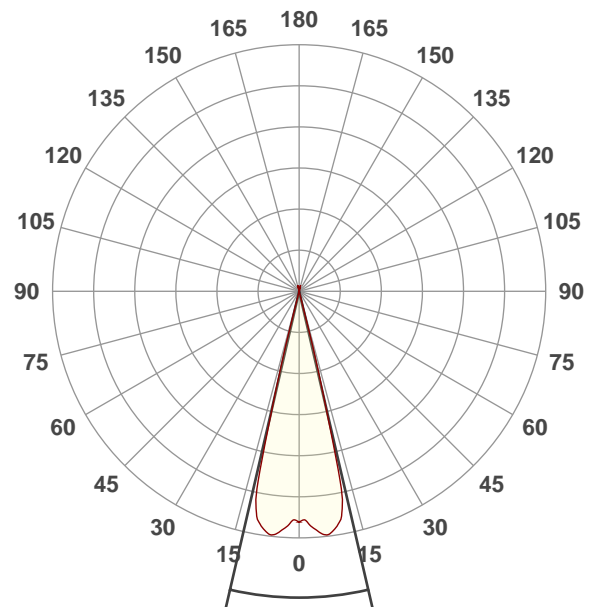

Beam angle 50%: 26,1°

Field angle 10%: 29°

Cut off angle 2.5%: 29,6°

Spectra

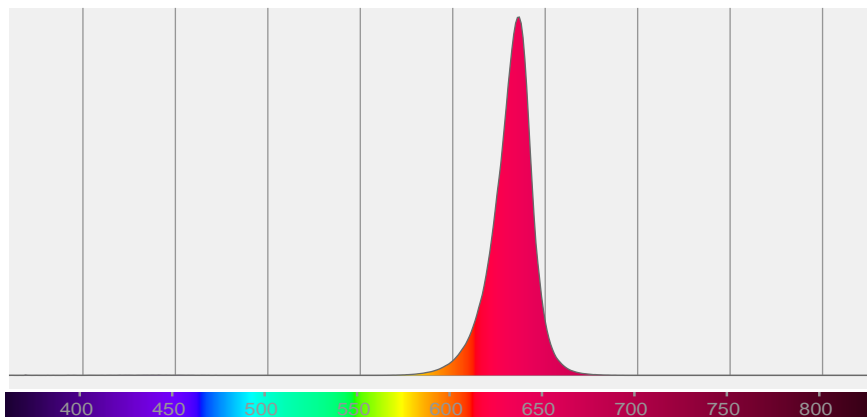

BEAM DETAILS



Beam angle 50%	Field angle 10%	Cut off angle 2,5%	Intensity ratio in 120° cone	Intensity ratio in 90° cone
26,1°	29°	29,6°	100,0%	100,0%

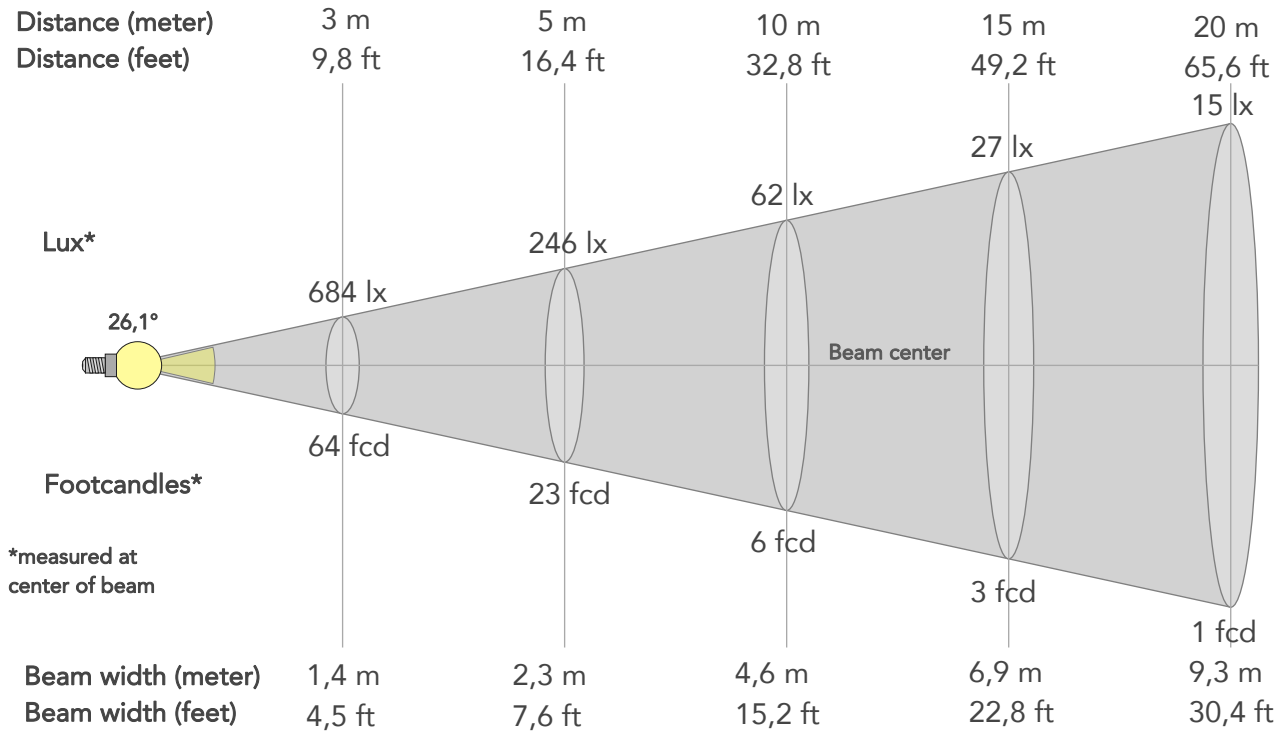

BEAM INTENSITIES AND WIDTHS

Distance	1m	2m	3m	4m	5m	7,5m	10m	15m	20m	25m	30m	40m	50m
Distance	3,3ft	6,6ft	9,8ft	13,1ft	16,4ft	24,6ft	32,8ft	49,2ft	65,6ft	82ft	98,4ft	131,2ft	164ft
Lux	6153lx	1538lx	684lx	385lx	246lx	109lx	62lx	27lx	15lx	10lx	7lx	4lx	2lx
Footcand.	572fcd	143fcd	64fcd	36fcd	23fcd	10fcd	6fcd	3fcd	1fcd	1fcd	1fcd	0fcd	0fcd
Beam wid.	0,5m	0,9m	1,4m	1,9m	2,3m	3,5m	4,6m	6,9m	9,3m	11,6m	13,9m	18,5m	23,2m
Beam wid.	1,5ft	3,1ft	4,5ft	6,1ft	7,6ft	11,4ft	15,2ft	22,8ft	30,4ft	38ft	45,6ft	60,8ft	76ft

LINEAR DISTRIBUTION DIAGRAM

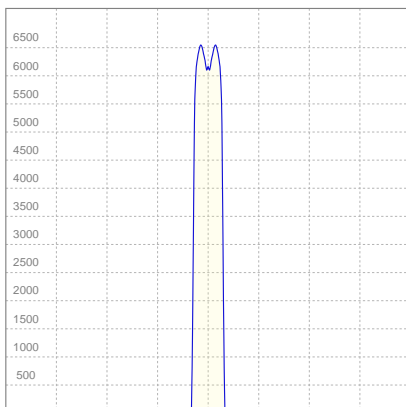

ELECTRICAL SPECIFICATIONS

Input voltage	Input current	Input power	Effeciency
227V	0,321A	52,9W	20lm/W

ISO CANDELA DIAGRAM

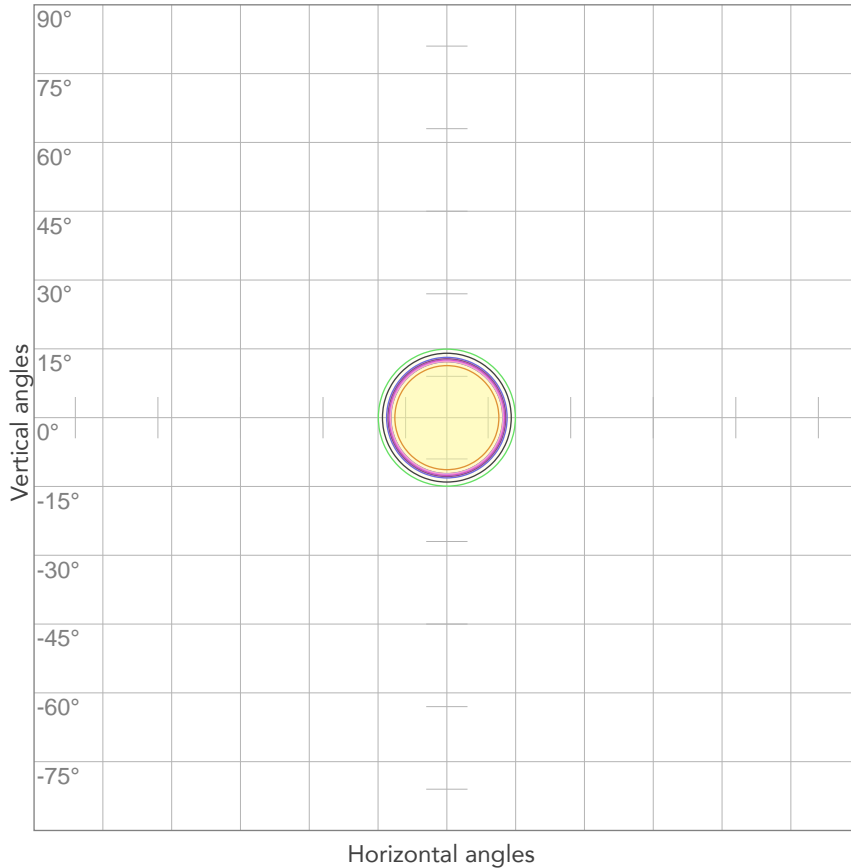

10%	615 cd
20%	1231 cd
30%	1846 cd
40%	2461 cd
50%	3077 cd
60%	3692 cd
70%	4307 cd
80%	4923 cd

Conditions:

Number of c-planes: 2

Candela at center: 6153 cd

ISO LUX DIAGRAM

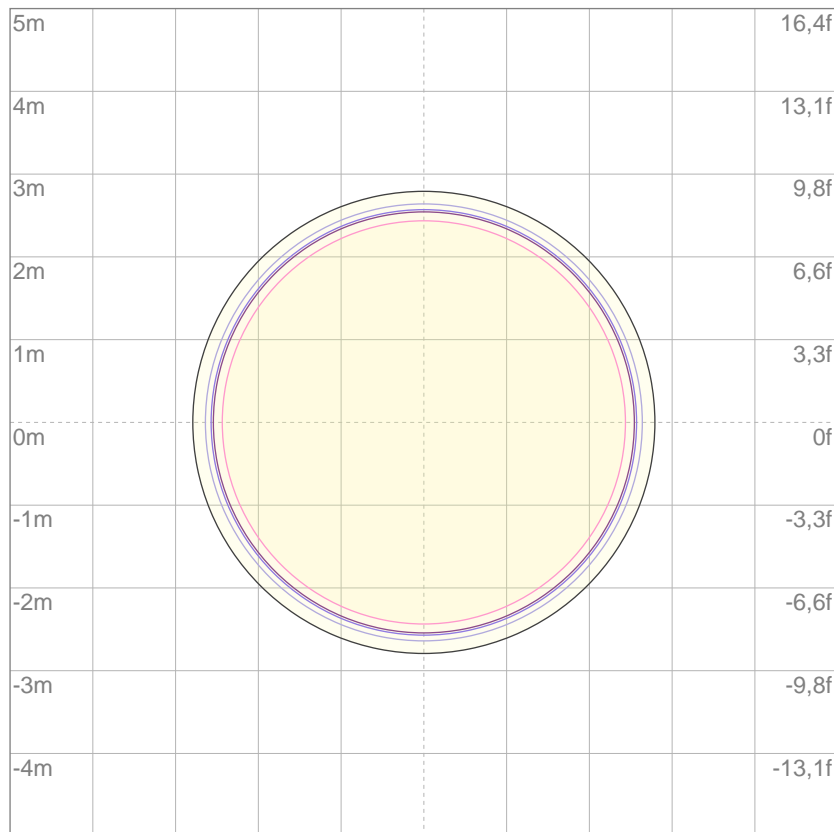

3%	1,85 lx
5%	3,08 lx
10%	6,15 lx
30%	18,5 lx
50%	30,8 lx

Conditions:

Number of c-planes: 2

Lux at center: 61,5 lx

Lux distribution on a surface when lamp is mounted at 10 meters from the surface.

Mounting height: 10 meters (33 feet)



Total lumen output:

1115 lm

Peak candela output:

7647 cd

PRODUCT NAME:

ECLCTPLUS

MEASURAMENT CONDITIONS:

Beam angle:

PRL26

Target:

Green HQ

Operator:

Paolo Carvone

Date and time:

14/07/2020 11:36:20

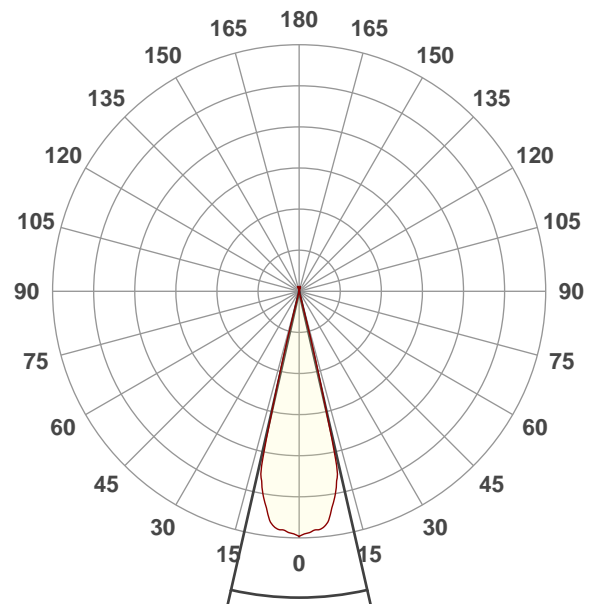

Beam angle 50%: 25,7°

Field angle 10%: 28,6°

Cut off angle 2.5%: 29,2°

Spectra

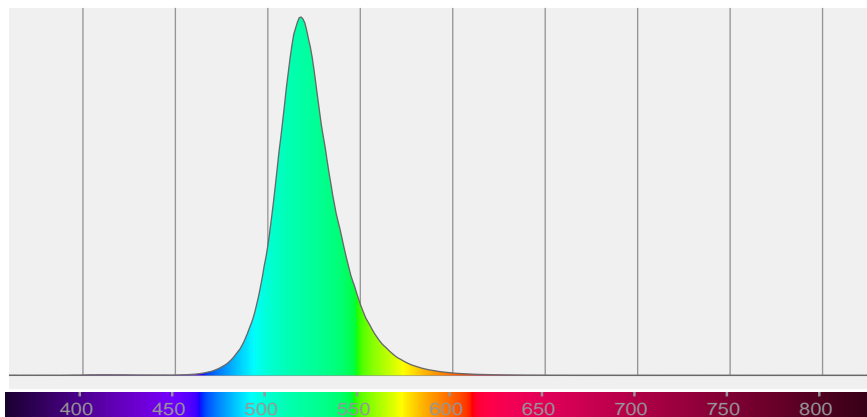

BEAM DETAILS



Beam angle 50%	Field angle 10%	Cut off angle 2,5%	Intensity ratio in 120° cone	Intensity ratio in 90° cone
25,7°	28,6°	29,2°	100,0%	99,9%

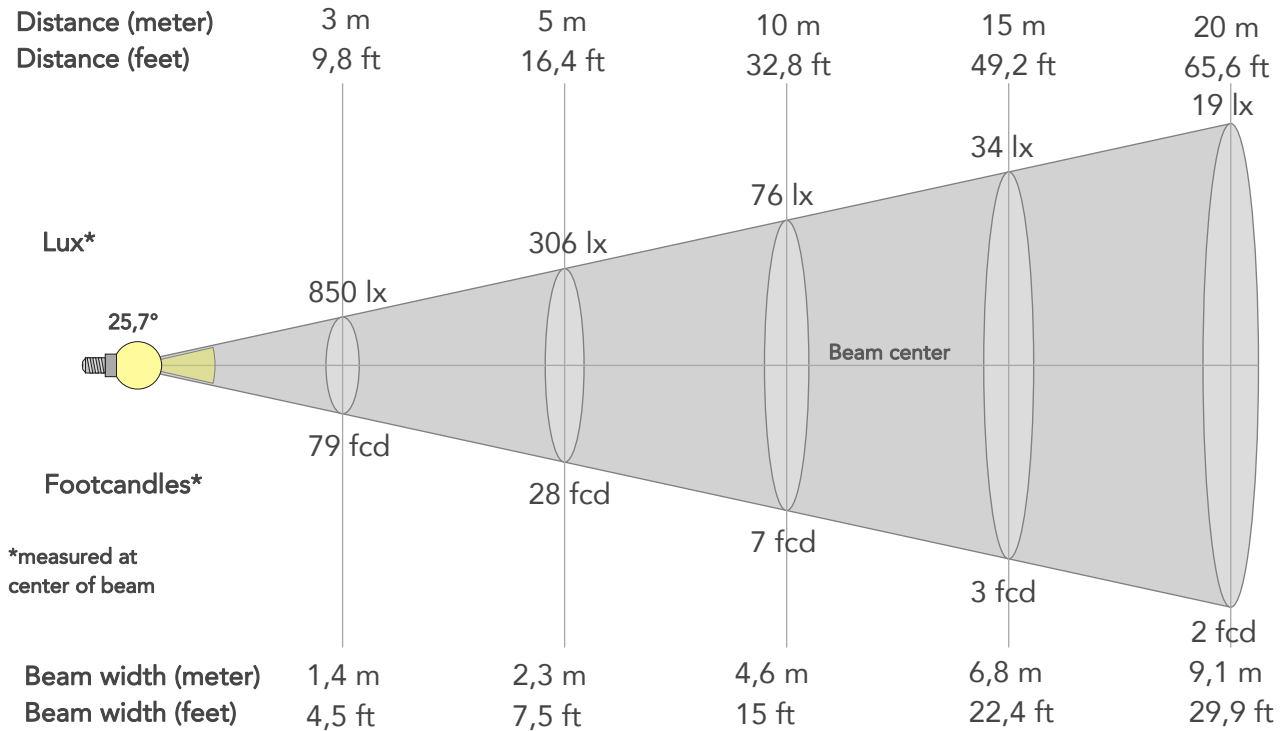

BEAM INTENSITIES AND WIDTHS

Distance	1m	2m	3m	4m	5m	7,5m	10m	15m	20m	25m	30m	40m	50m
Distance	3,3ft	6,6ft	9,8ft	13,1ft	16,4ft	24,6ft	32,8ft	49,2ft	65,6ft	82ft	98,4ft	131,2ft	164ft
Lux	7647lx	1912lx	850lx	478lx	306lx	136lx	76lx	34lx	19lx	12lx	8lx	5lx	3lx
Footcand.	710fcd	178fcd	79fcd	44fcd	28fcd	13fcd	7fcd	3fcd	2fcd	1fcd	1fcd	0fcd	0fcd
Beam wid.	0,5m	0,9m	1,4m	1,8m	2,3m	3,4m	4,6m	6,8m	9,1m	11,4m	13,7m	18,2m	22,8m
Beam wid.	1,5ft	3ft	4,5ft	6ft	7,5ft	11,2ft	15ft	22,4ft	29,9ft	37,4ft	44,9ft	59,9ft	74,8ft

LINEAR DISTRIBUTION DIAGRAM

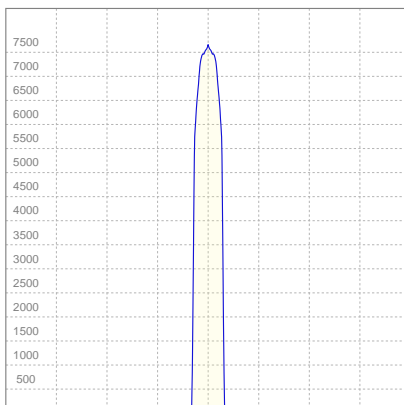

ELECTRICAL SPECIFICATIONS

Input voltage	Input current	Input power	Effeciency
227V	0,299A	47,3W	24lm/W

ISO CANDELA DIAGRAM

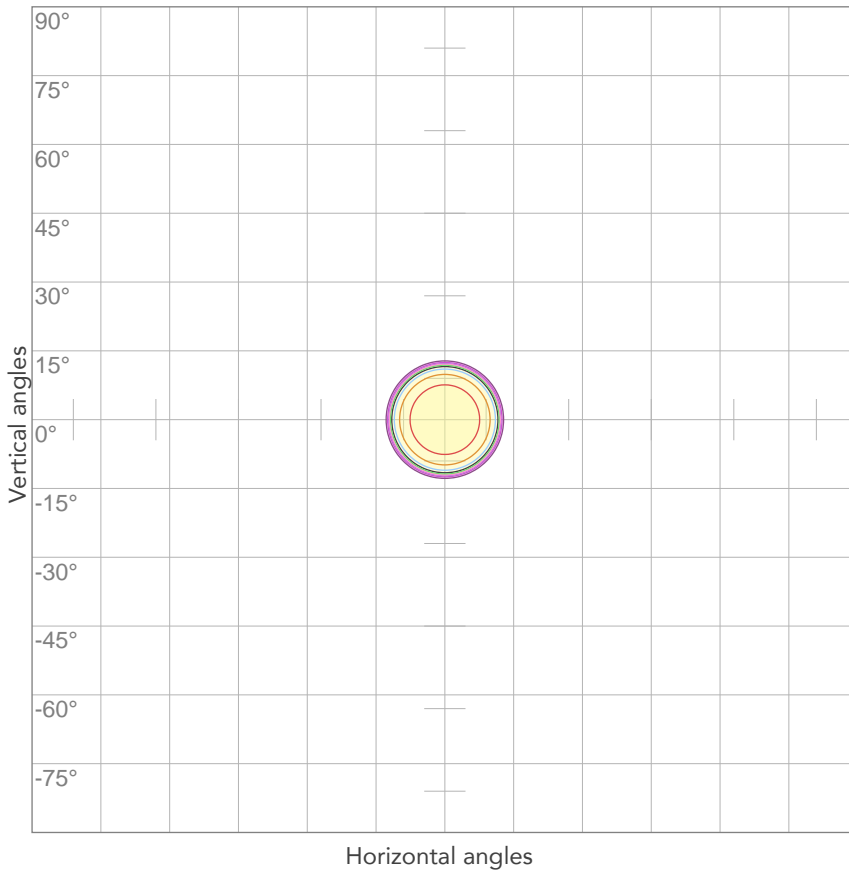

10%	765 cd
20%	1529 cd
30%	2294 cd
40%	3059 cd
50%	3823 cd
60%	4588 cd
70%	5353 cd
80%	6117 cd

Conditions:

Number of c-planes: 2

Candela at center: 7647 cd

ISO LUX DIAGRAM

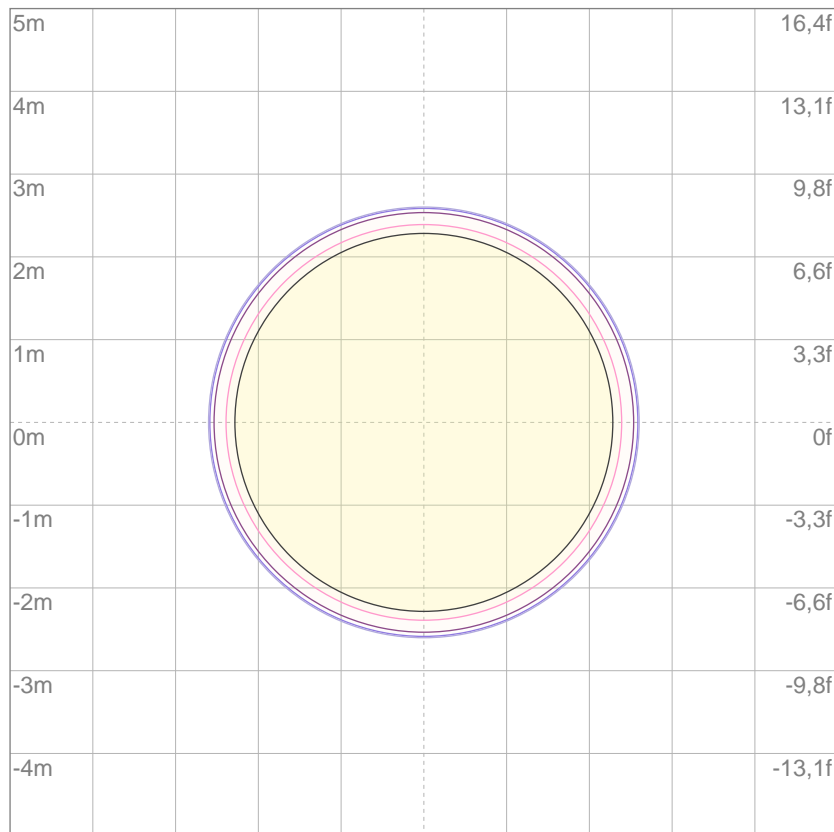

3%	2,29 lx
5%	3,82 lx
10%	7,65 lx
30%	22,9 lx
50%	38,2 lx

Conditions:

Number of c-planes: 2

Lux at center: 76,5 lx

Lux distribution on a surface when lamp is mounted at 10 meters from the surface.

Mounting height: 10 meters (33 feet)



Total lumen output:

125 lm

Peak candela output:

849 cd

PRODUCT NAME:

ECLCTPLUS

MEASURAMENT CONDITIONS:

Beam angle:

PRL26

Target:

Blue HQ

Operator:

Paolo Carvone

Date and time:

14/07/2020 11:38:02

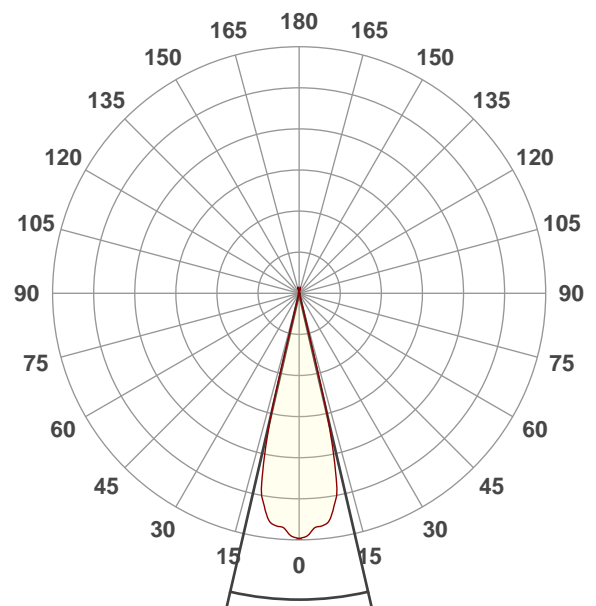

Beam angle 50%: 26°

Field angle 10%: 29°

Cut off angle 2.5%: 29,6°

Spectra

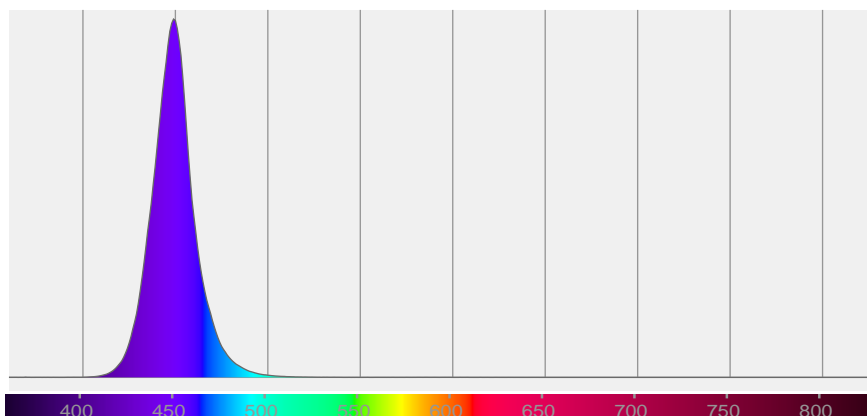

BEAM DETAILS



Beam angle 50%	Field angle 10%	Cut off angle 2,5%	Intensity ratio in 120° cone	Intensity ratio in 90° cone
26°	29°	29,6°	100,0%	99,9%

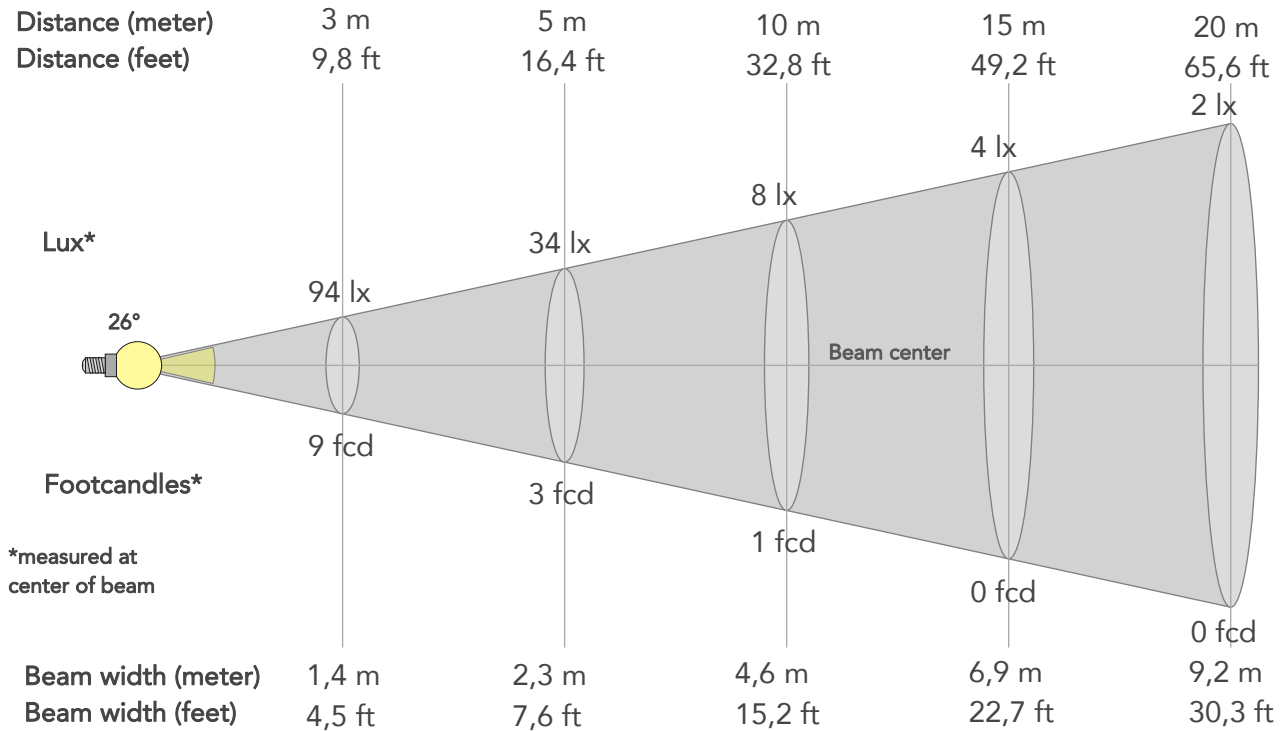

BEAM INTENSITIES AND WIDTHS

Distance	1m	2m	3m	4m	5m	7,5m	10m	15m	20m	25m	30m	40m	50m
Distance	3,3ft	6,6ft	9,8ft	13,1ft	16,4ft	24,6ft	32,8ft	49,2ft	65,6ft	82ft	98,4ft	131,2ft	164ft
Lux	849lx	212lx	94lx	53lx	34lx	15lx	8lx	4lx	2lx	1lx	1lx	1lx	0lx
Footcand.	79fcd	20fcd	9fcd	5fcd	3fcd	1fcd	1fcd	0fcd	0fcd	0fcd	0fcd	0fcd	0fcd
Beam wid.	0,5m	0,9m	1,4m	1,8m	2,3m	3,5m	4,6m	6,9m	9,2m	11,5m	13,9m	18,5m	23,1m
Beam wid.	1,5ft	3ft	4,5ft	6,1ft	7,6ft	11,4ft	15,2ft	22,7ft	30,3ft	37,9ft	45,5ft	60,6ft	75,8ft

LINEAR DISTRIBUTION DIAGRAM

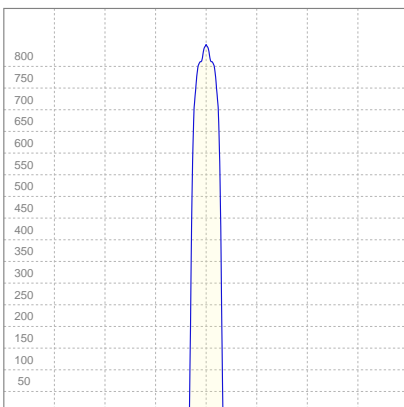

ELECTRICAL SPECIFICATIONS

Input voltage	Input current	Input power	Effeciency
227V	0,237A	32,1W	4lm/W

ISO CANDELA DIAGRAM

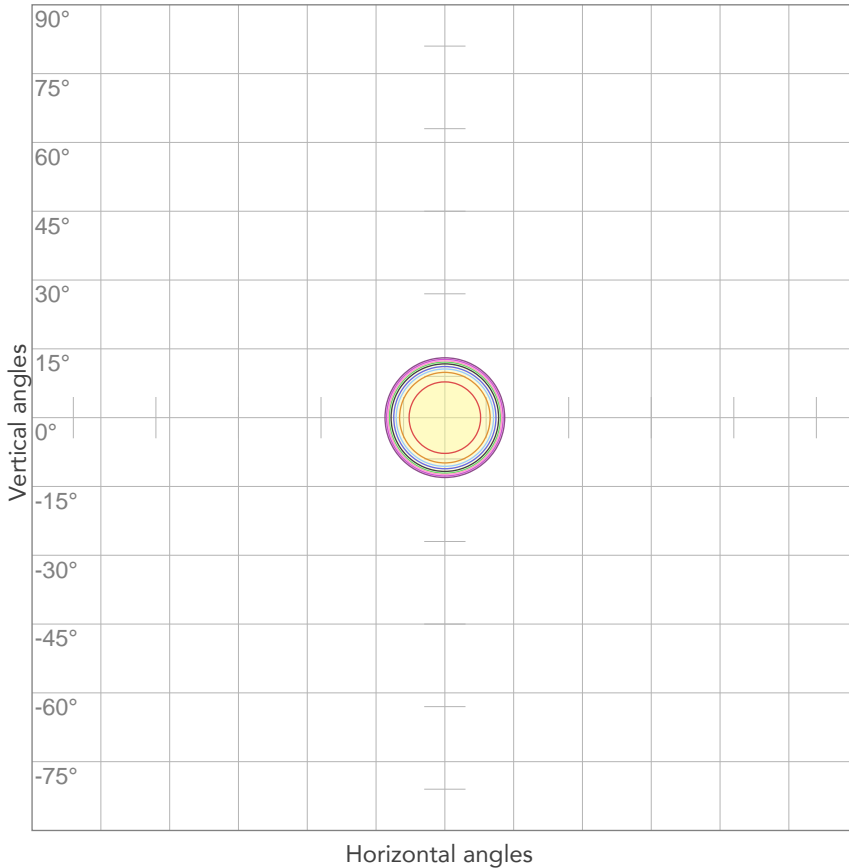

10%	85 cd
20%	170 cd
30%	255 cd
40%	340 cd
50%	424 cd
60%	509 cd
70%	594 cd
80%	679 cd

Conditions:

Number of c-planes: 2
Candela at center: 849 cd

ISO LUX DIAGRAM

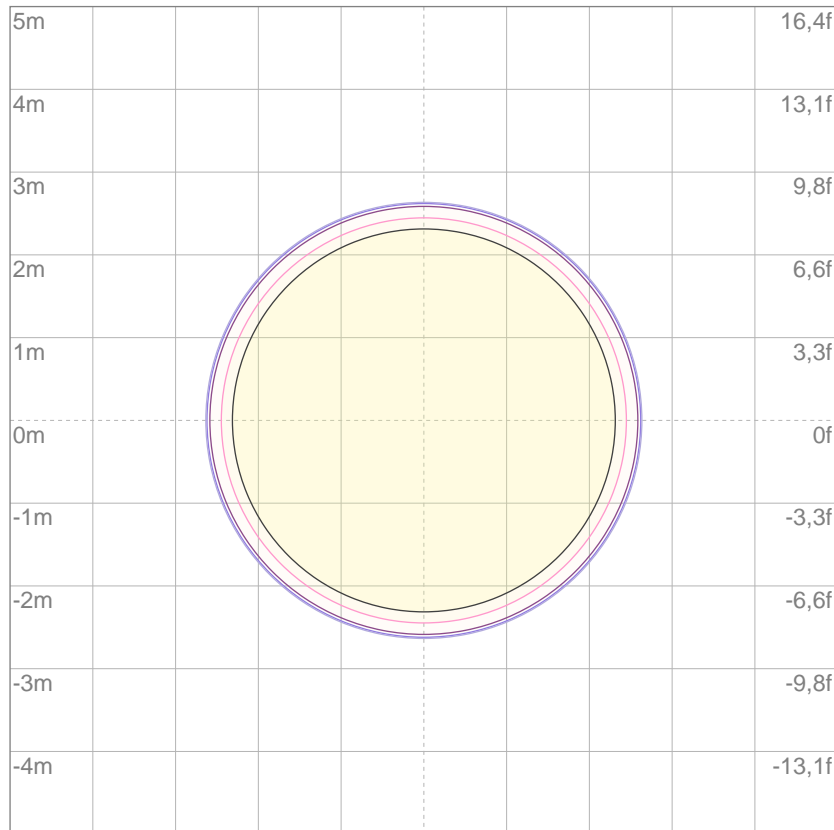

3%	0,255 lx
5%	0,424 lx
10%	0,849 lx
30%	2,55 lx
50%	4,24 lx

Conditions:

Number of c-planes: 2
Lux at center: 8,49 lx

Lux distribution on a surface when lamp is mounted at 10 meters from the surface.

Mounting height: 10 meters (33 feet)



Total lumen output:

5355 lm

Peak candela output:

35065 cd

Light quality:

CRI: 92,3

Color temperature:

2816 K

PRODUCT NAME:
ECLCTPLUS

MEASURAMENT CONDITIONS:

Beam angle:
PRL26

Target:
2800K HQ

Operator:
Paolo Carvone

Date and time:
14/07/2020 11:40:25

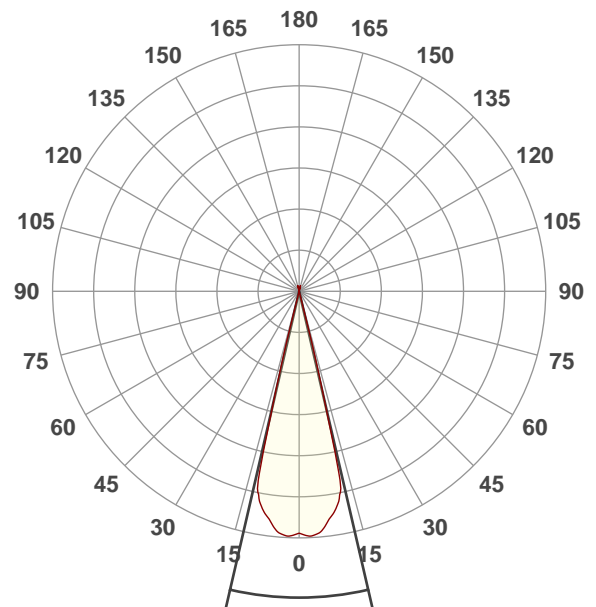

Beam angle 50%: 26,1°
Field angle 10%: 28,7°
Cut off angle 2.5%: 29,3°

Spectra

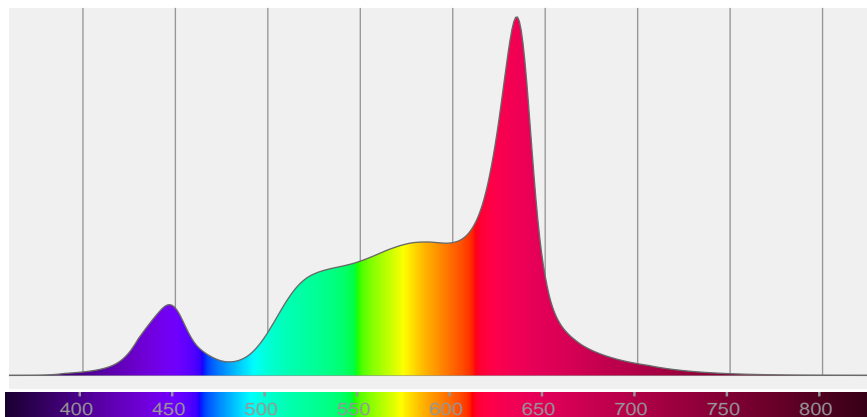

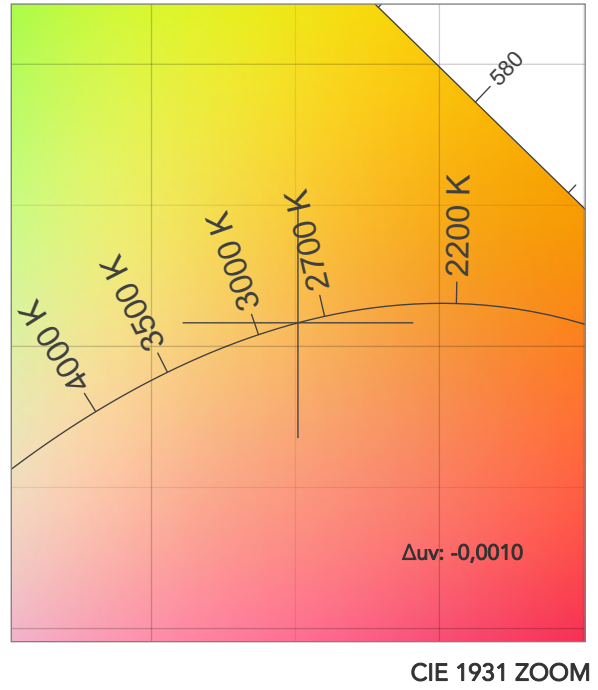
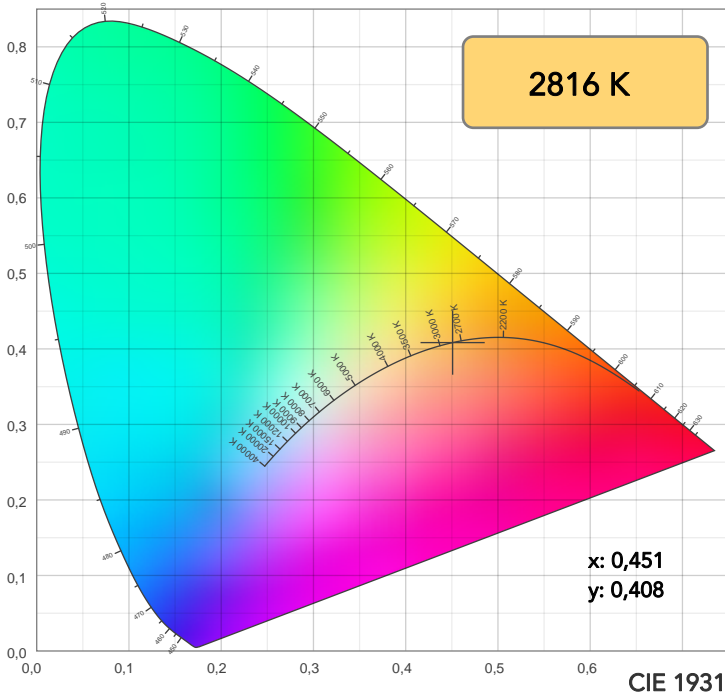

TM30: 84,2

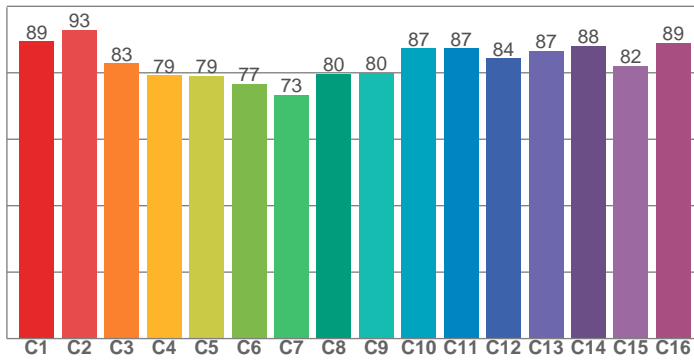

CRI: 92,3 (R1-R8)

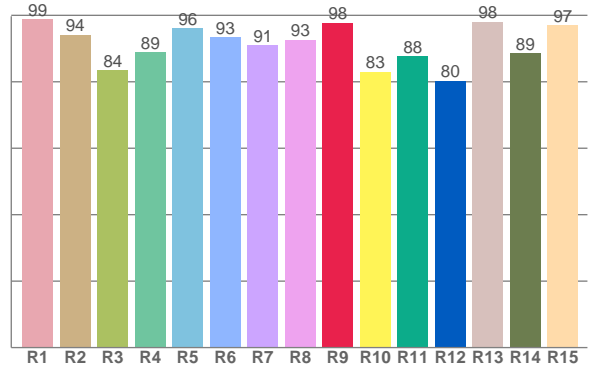

CQS: 87,0

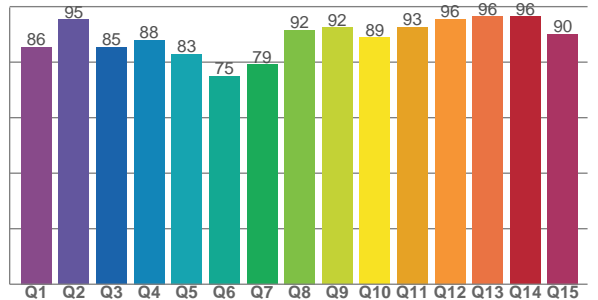

CRI R values, only R1-R8 are used to calculate final CRI value

R1	R2	R3	R4	R5	R6	R7	R8	R9	R10	R11	R12	R13	R14	R15
98,7	94,1	83,6	88,9	96,1	93,4	91,0	92,7	97,7	83,0	87,7	80,3	98,1	88,7	97,1

TM30 C values, 16 binned values out of total of 99 C values

C1	C2	C3	C4	C5	C6	C7	C8	C9	C10	C11	C12	C13	C14	C15	C16
89,4	93,0	82,9	79,2	79,1	76,7	73,4	79,6	79,9	87,3	87,4	84,4	86,6	88,1	82,2	89,0

CQS Q values

Q1	Q2	Q3	Q4	Q5	Q6	Q7	Q8	Q9	Q10	Q11	Q12	Q13	Q14	Q15
85,5	95,4	85,4	87,9	82,9	75,0	79,1	91,6	92,4	88,9	92,6	95,6	96,4	96,4	90,1

COLOR PARAMETERS

Color temperature	Color rendering index	Red component	Color fidelity	Color gamut	Color quality scale	Television lighting index	Color coordinate cie 1931	Color coordinate cie 1931	Color deviation from black body
CCT	CRI	CRI R9	TM30 Rf	TM30 Rg	CQS	TLCI	x	y	Δuv
2816 K	92,3	97,7	84,2	108,5	87,0	70	0,451	0,408	-0,0010

TM30 DETAILS

Rf 84,2
Fidelity index Rf

Rg 108,5
Gammut index

Hue Bin	R _f	Graphic shifts (%)	
		Chroma	Hue
1	89	-1%	-4%
2	93	-1%	1%
3	83	1%	8%
4	79	8%	10%
5	79	13%	9%
6	77	14%	2%
7	73	12%	-10%
8	80	6%	-11%
9	80	-1%	-11%
10	87	-5%	-5%
11	87	-5%	5%
12	84	3%	4%
13	87	8%	-2%
14	88	7%	-1%
15	82	7%	-6%
16	89	3%	-6%

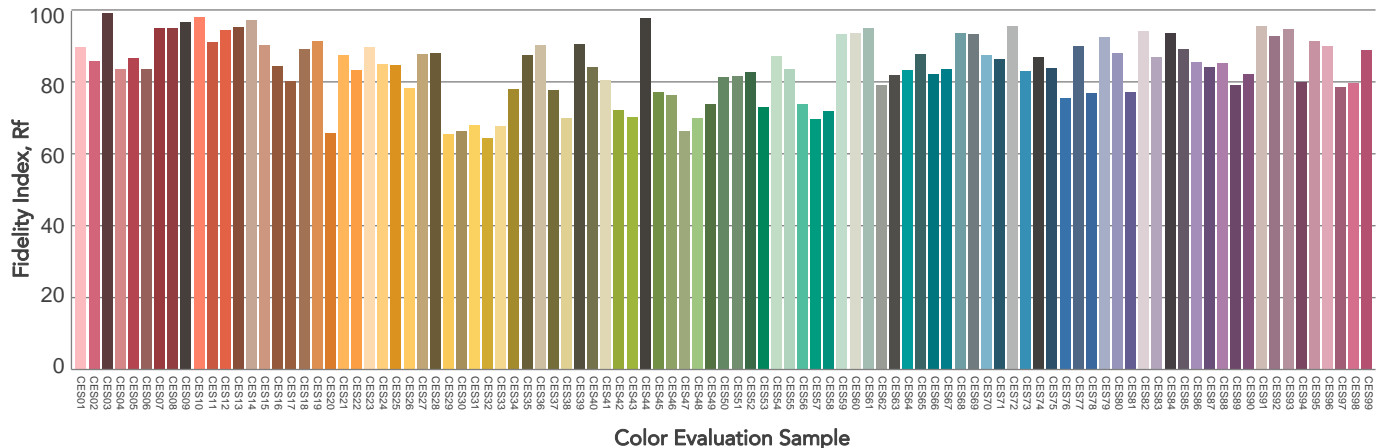
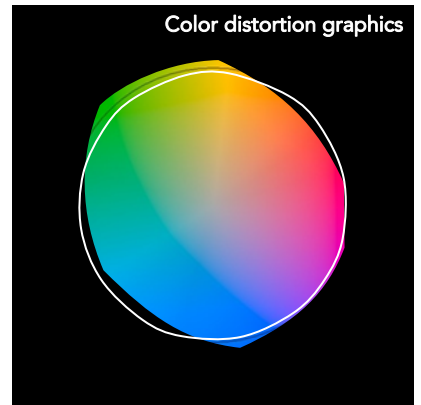
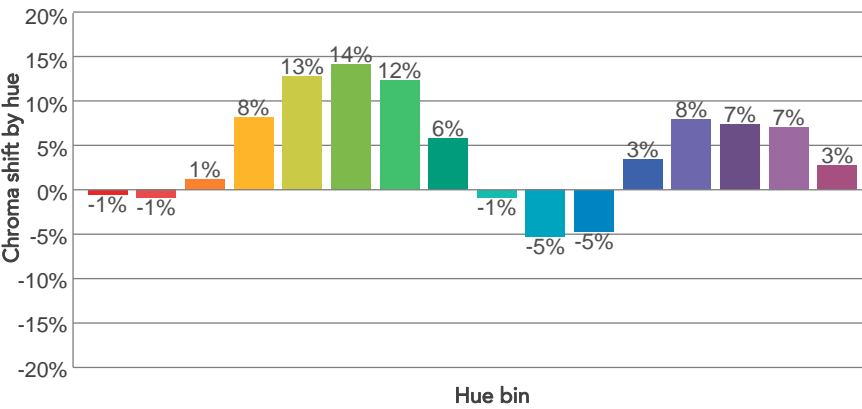
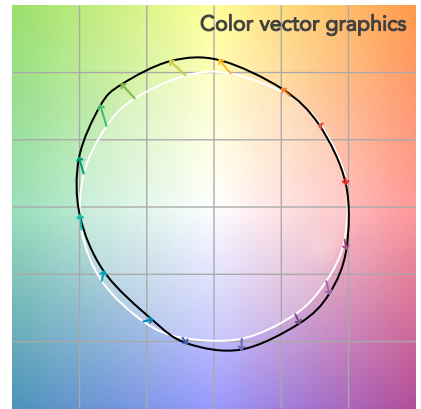
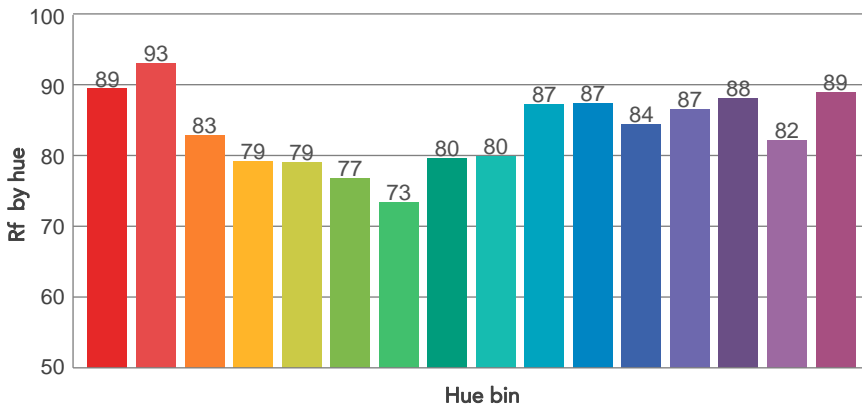
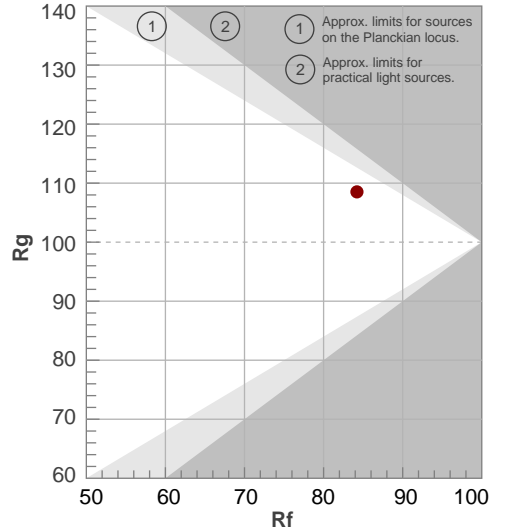

BEAM DETAILS



Beam angle 50%	Field angle 10%	Cut off angle 2,5%	Intensity ratio in 120° cone	Intensity ratio in 90° cone
26,1°	28,7°	29,3°	100,0%	100,0%

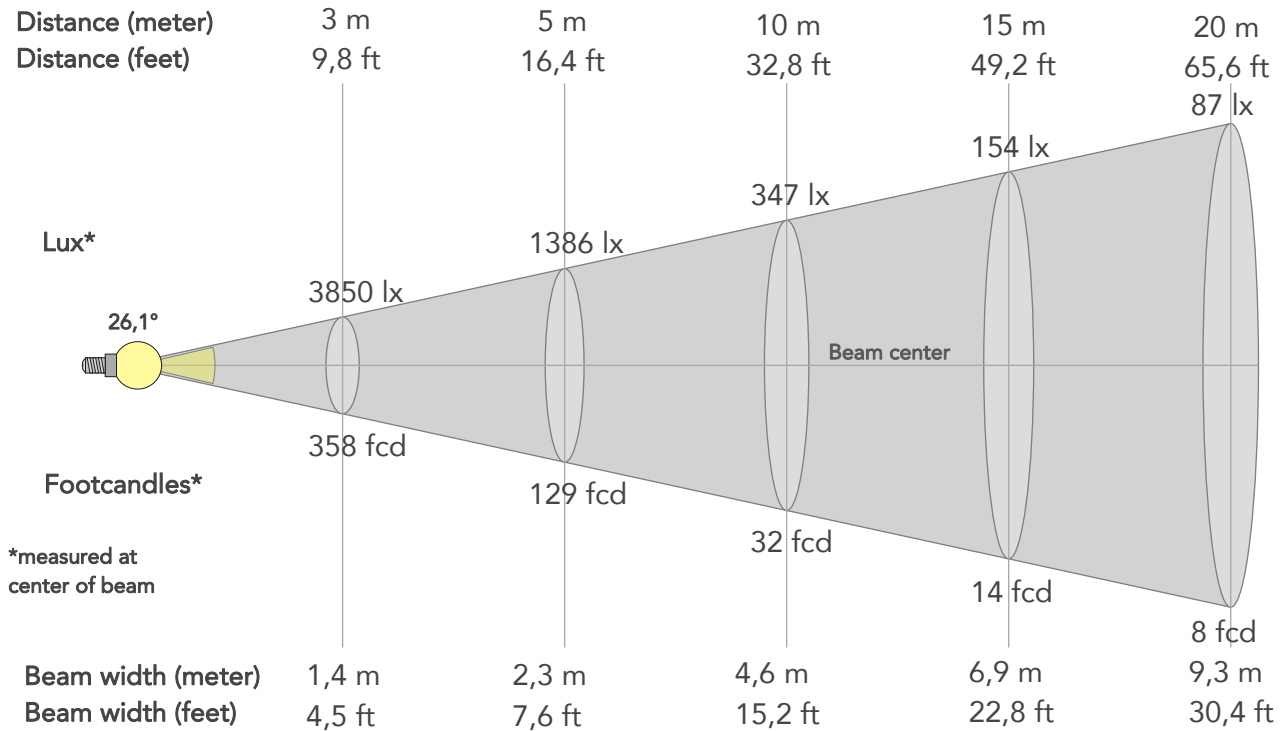

*measured at center of beam

BEAM INTENSITIES AND WIDTHS

Distance	1m	2m	3m	4m	5m	7,5m	10m	15m	20m	25m	30m	40m	50m
Distance	3,3ft	6,6ft	9,8ft	13,1ft	16,4ft	24,6ft	32,8ft	49,2ft	65,6ft	82ft	98,4ft	131,2ft	164ft
Lux	34652lx	8663lx	3850lx	2166lx	1386lx	616lx	347lx	154lx	87lx	55lx	39lx	22lx	14lx
Footcand.	3219fcd	805fcd	358fcd	201fcd	129fcd	57fcd	32fcd	14fcd	8fcd	5fcd	4fcd	2fcd	1fcd
Beam wid.	0,5m	0,9m	1,4m	1,9m	2,3m	3,5m	4,6m	6,9m	9,3m	11,6m	13,9m	18,5m	23,1m
Beam wid.	1,5ft	3,1ft	4,5ft	6,1ft	7,6ft	11,4ft	15,2ft	22,8ft	30,4ft	38ft	45,5ft	60,7ft	75,9ft

LINEAR DISTRIBUTION DIAGRAM

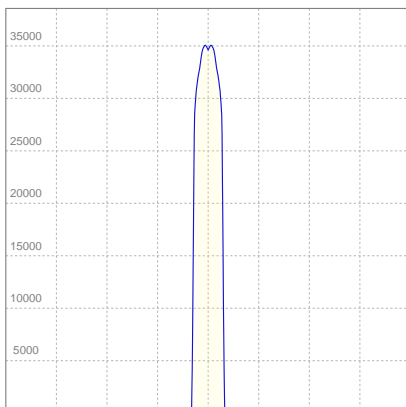

ELECTRICAL SPECIFICATIONS

Input voltage	Input current	Input power	Effeciency
226V	0,808A	168,1W	32lm/W

ISO CANDELA DIAGRAM

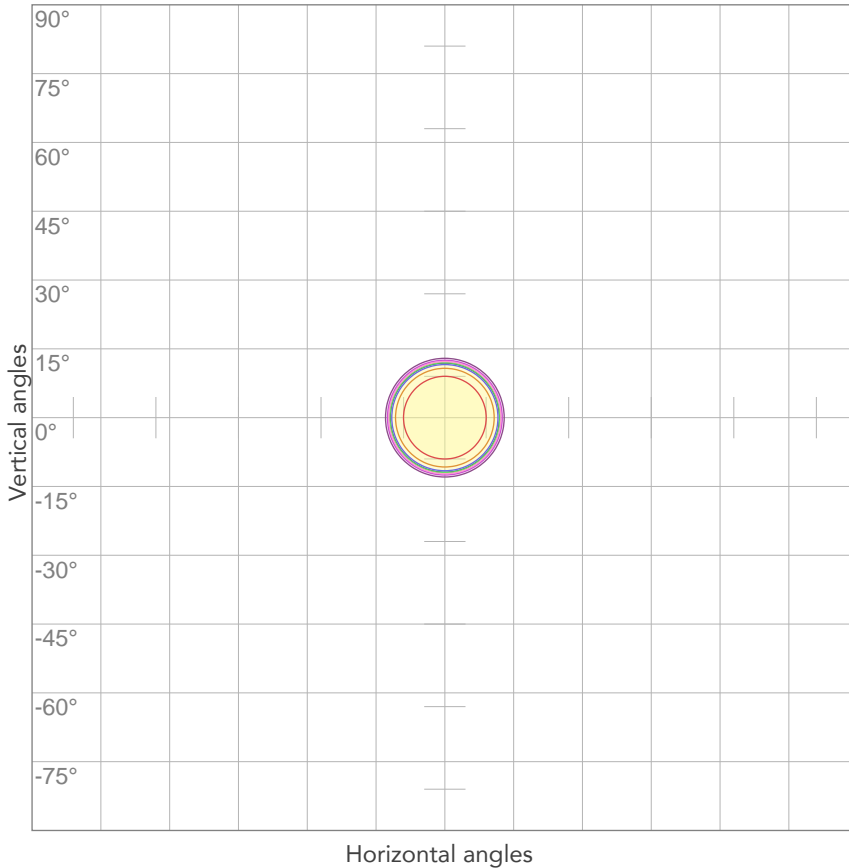

10%	3465 cd
20%	6930 cd
30%	10396 cd
40%	13861 cd
50%	17326 cd
60%	20791 cd
70%	24257 cd
80%	27722 cd

Conditions:

Number of c-planes: 2

Candela at center: 34652 cd

ISO LUX DIAGRAM

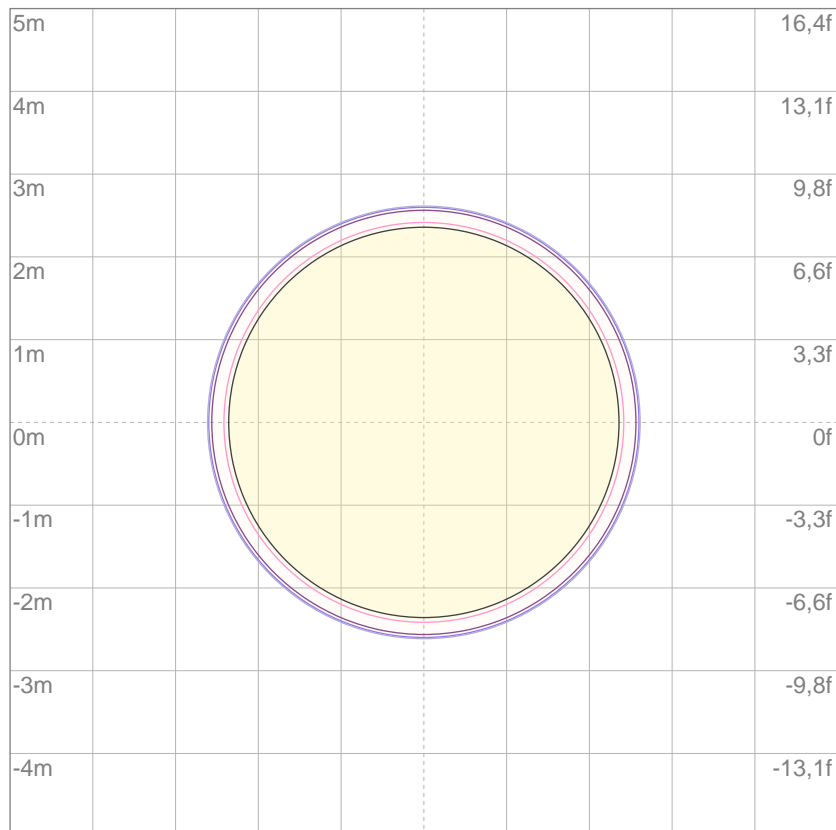

3%	10,4 lx
5%	17,3 lx
10%	34,7 lx
30%	104 lx
50%	173 lx

Conditions:

Number of c-planes: 2

Lux at center: 347 lx

Lux distribution on a surface when lamp is mounted at 10 meters from the surface.

Mounting height: 10 meters (33 feet)



Total lumen output:

5570 lm

Peak candela output:

36579 cd

Light quality:

CRI: 93,3

Color temperature:

3220 K

PRODUCT NAME:

ECLCTPLUS

MEASURAMENT CONDITIONS:

Beam angle:

PRL26

Target:

3200K HQ

Operator:

Paolo Carvone

Date and time:

14/07/2020 11:42:18

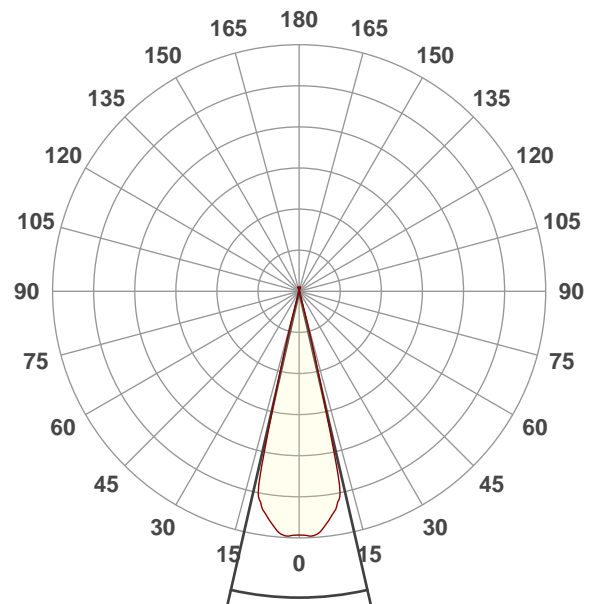

Spectra

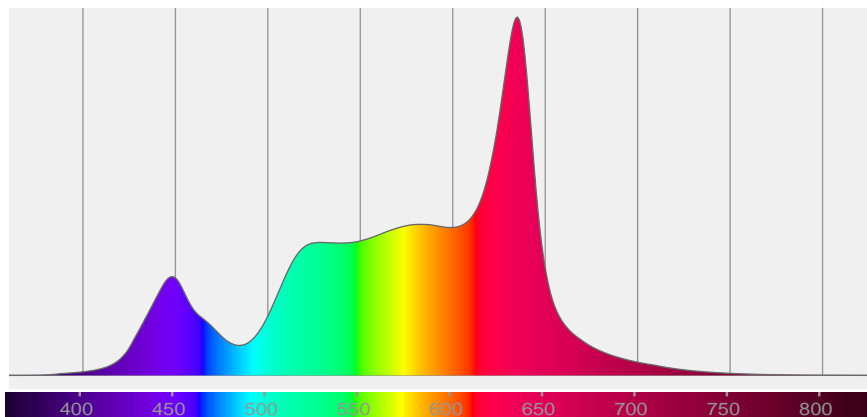

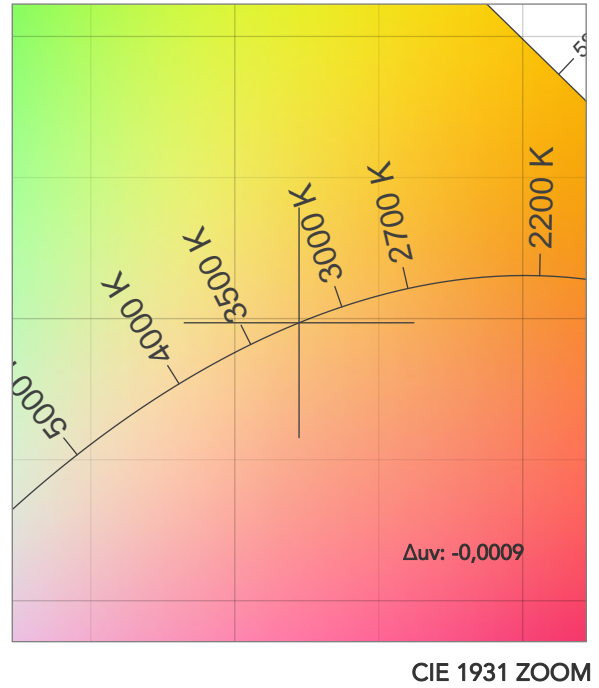
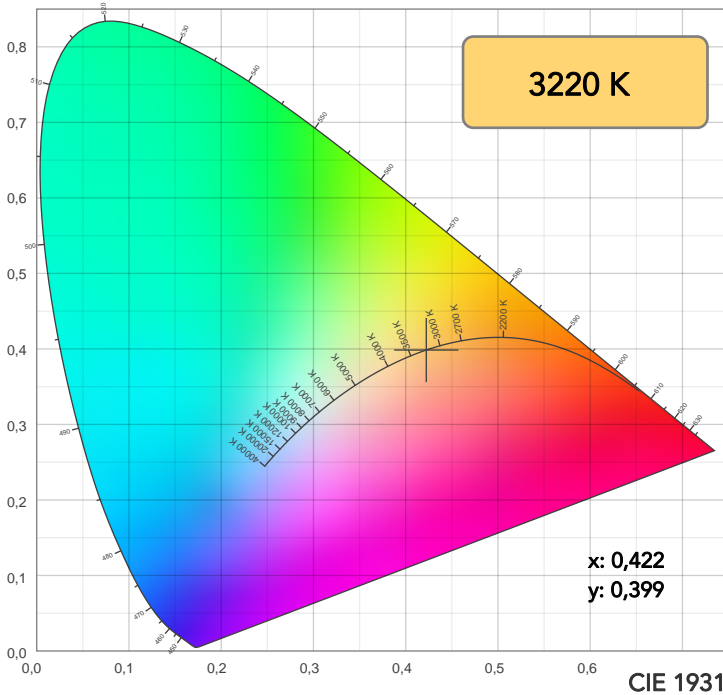

TM30: 89,0

CRI: 93,3 (R1-R8)

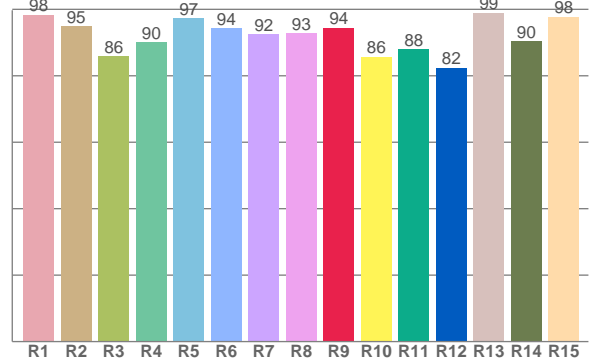
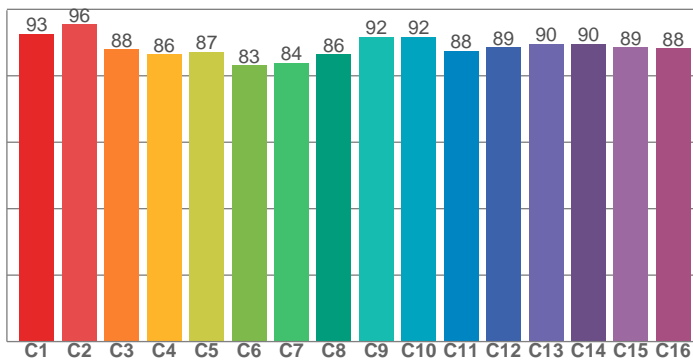

CRI R values, only R1-R8 are used to calculate final CRI value

R1	R2	R3	R4	R5	R6	R7	R8	R9	R10	R11	R12	R13	R14	R15
98,4	95,0	85,8	90,1	97,4	94,3	92,4	92,7	94,5	85,7	88,0	82,4	98,9	90,3	97,8

TM30 C values, 16 binned values out of total of 99 C values

C1	C2	C3	C4	C5	C6	C7	C8	C9	C10	C11	C12	C13	C14	C15	C16
92,6	95,5	88,0	86,4	87,2	83,1	83,8	86,5	91,7	91,8	87,5	88,6	89,6	89,6	88,5	88,2

CQS Q values

Q1	Q2	Q3	Q4	Q5	Q6	Q7	Q8	Q9	Q10	Q11	Q12	Q13	Q14	Q15
92,4	96,8	86,2	91,2	90,0	83,7	85,7	95,4	92,8	90,9	94,7	97,3	96,8	97,3	94,7

CQS: 91,1

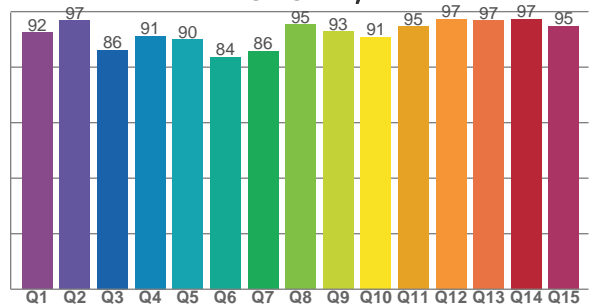

COLOR PARAMETERS

Color temperature	Color rendering index	Red component	Color fidelity	Color gamut	Color quality scale	Television lighting index	Color coordinate cie 1931	Color coordinate cie 1931	Color deviation from black body
CCT	CRI	CRI R9	TM30 Rf	TM30 Rg	CQS	TLCI	x	y	Δuv
3220 K	93,3	94,5	89,0	106,6	91,1	84	0,422	0,399	-0,0009

TM30 DETAILS

Rf 89,0
Fidelity index Rf

Rg 106,6
Gammut index

Hue Bin	R _f	Graphic shifts (%)	
		Chroma	Hue
1	93	0%	-3%
2	96	-1%	1%
3	88	1%	5%
4	86	4%	7%
5	87	7%	7%
6	83	10%	2%
7	84	8%	-5%
8	86	4%	-7%
9	92	0%	-5%
10	92	-4%	0%
11	88	-2%	7%
12	89	4%	2%
13	90	6%	-1%
14	90	7%	-1%
15	89	5%	-4%
16	88	4%	-7%

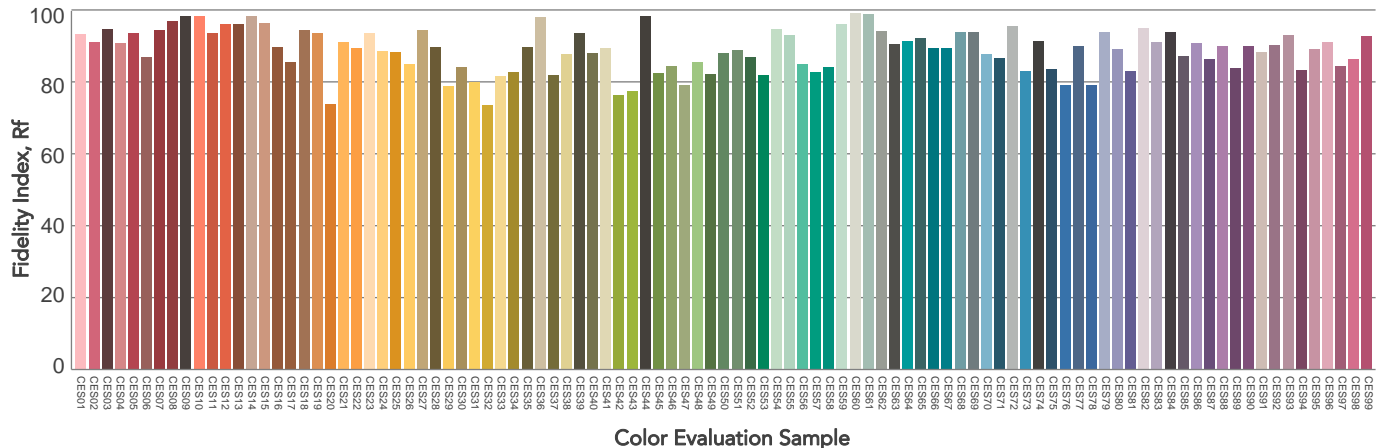
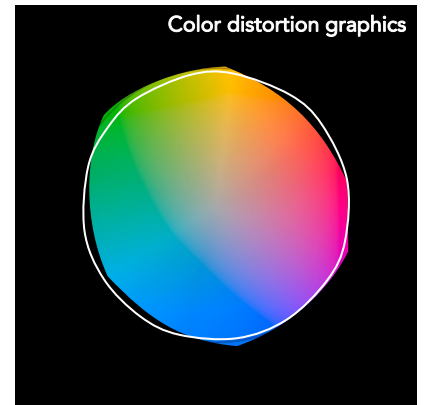
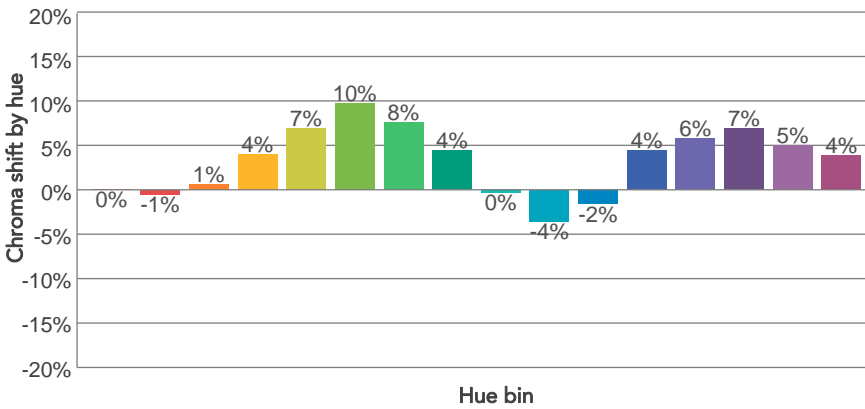
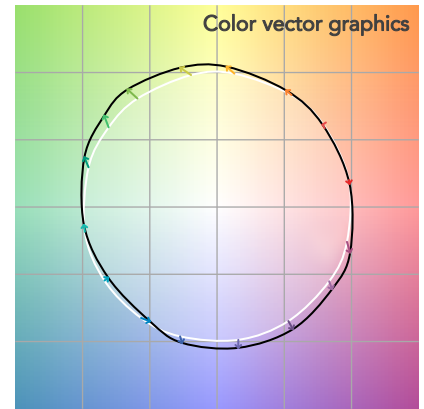
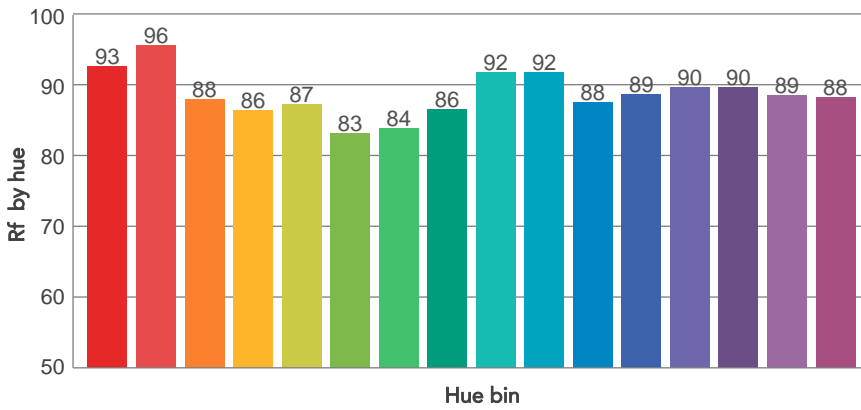
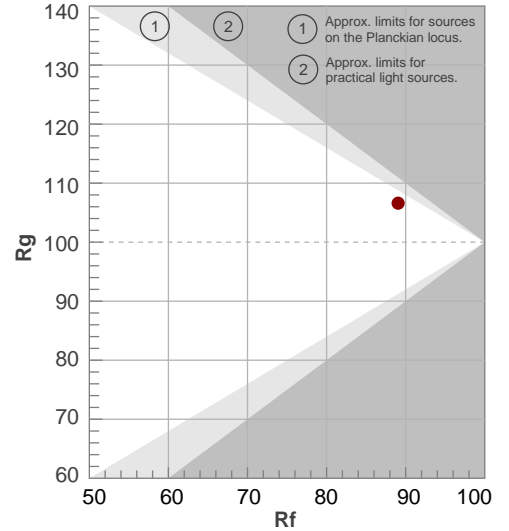

BEAM DETAILS



Beam angle 50%	Field angle 10%	Cut off angle 2,5%	Intensity ratio in 120° cone	Intensity ratio in 90° cone
25,8°	29,6°	30,7°	100,0%	100,0%

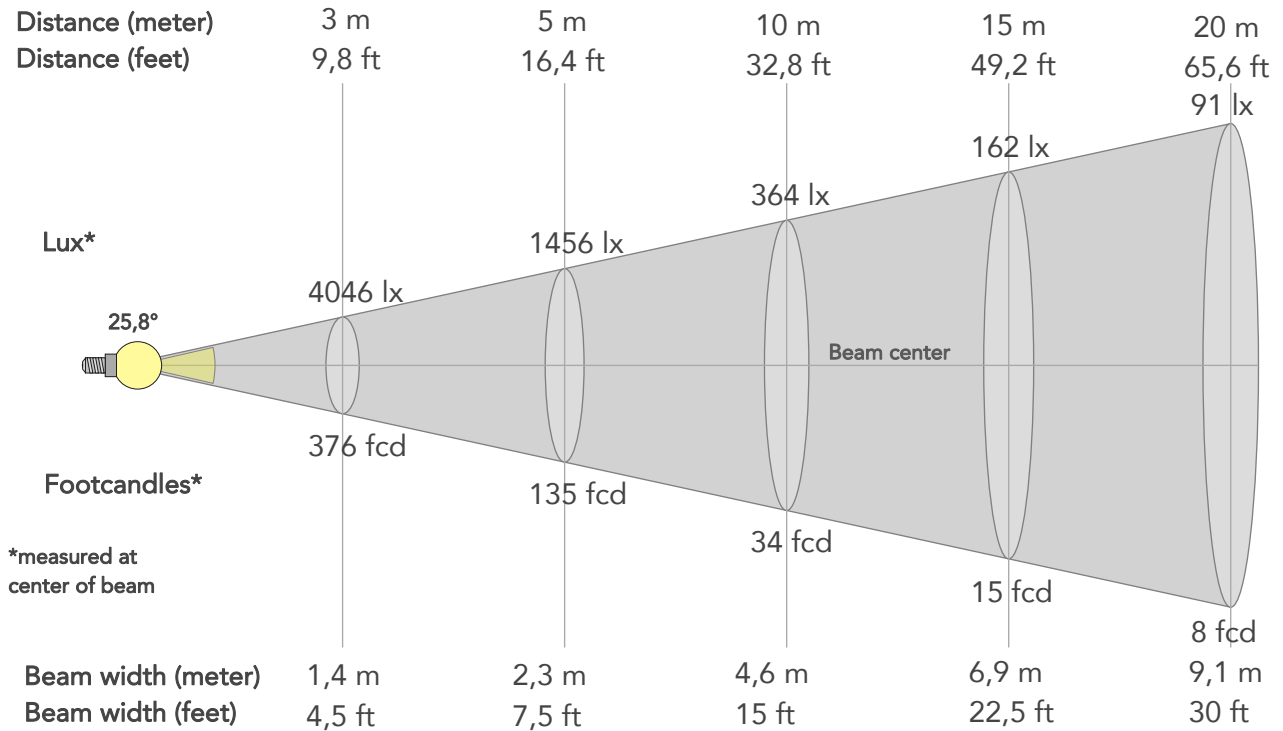

BEAM INTENSITIES AND WIDTHS

Distance	1m	2m	3m	4m	5m	7,5m	10m	15m	20m	25m	30m	40m	50m
Distance	3,3ft	6,6ft	9,8ft	13,1ft	16,4ft	24,6ft	32,8ft	49,2ft	65,6ft	82ft	98,4ft	131,2ft	164ft
Lux	36412lx	9103lx	4046lx	2276lx	1456lx	647lx	364lx	162lx	91lx	58lx	40lx	23lx	15lx
Footcand.	3383fcd	846fcd	376fcd	211fcd	135fcd	60fcd	34fcd	15fcd	8fcd	5fcd	4fcd	2fcd	1fcd
Beam wid.	0,5m	0,9m	1,4m	1,8m	2,3m	3,4m	4,6m	6,9m	9,1m	11,4m	13,7m	18,3m	22,9m
Beam wid.	1,5ft	3ft	4,5ft	6ft	7,5ft	11,2ft	15ft	22,5ft	30ft	37,5ft	45ft	60ft	75ft

LINEAR DISTRIBUTION DIAGRAM

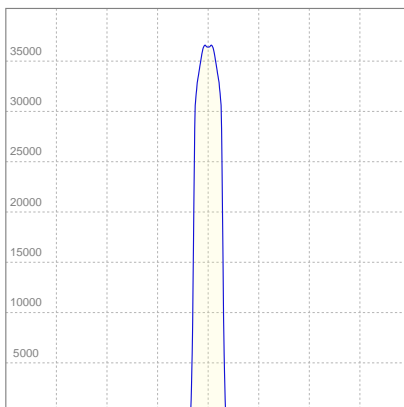

ELECTRICAL SPECIFICATIONS

Input voltage	Input current	Input power	Effeciency
226V	0,853A	179,1W	31lm/W

ISO CANDELA DIAGRAM

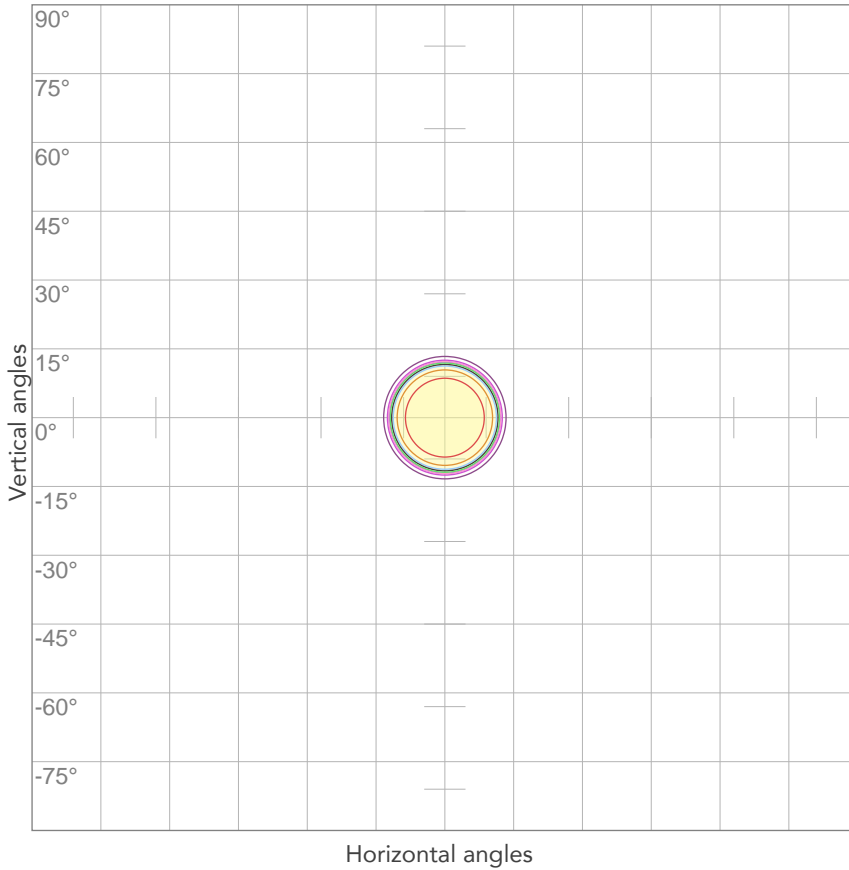

10%	3641 cd
20%	7282 cd
30%	10923 cd
40%	14565 cd
50%	18206 cd
60%	21847 cd
70%	25488 cd
80%	29129 cd

Conditions:

Number of c-planes: 2

Candela at center: 36412 cd

ISO LUX DIAGRAM

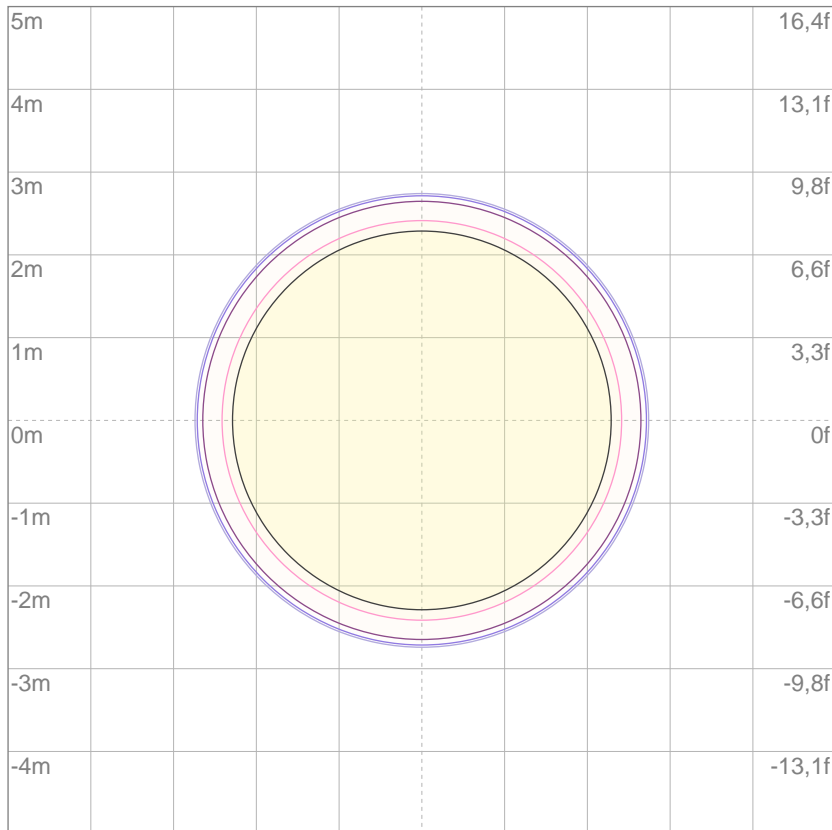

3%	10,9 lx
5%	18,2 lx
10%	36,4 lx
30%	109 lx
50%	182 lx

Conditions:

Number of c-planes: 2

Lux at center: 364 lx

Lux distribution on a surface when lamp is mounted at 10 meters from the surface.

Mounting height: 10 meters (33 feet)



Total lumen output:

5858 lm

Peak candela output:

38336 cd

Light quality:

CRI: 95,3

Color temperature:

3979 K

PRODUCT NAME:
ECLCTPLUS

MEASURAMENT CONDITIONS:

Beam angle:
PRL26

Target:
4000K HQ

Operator:
Paolo Carvone

Date and time:
14/07/2020 11:44:30

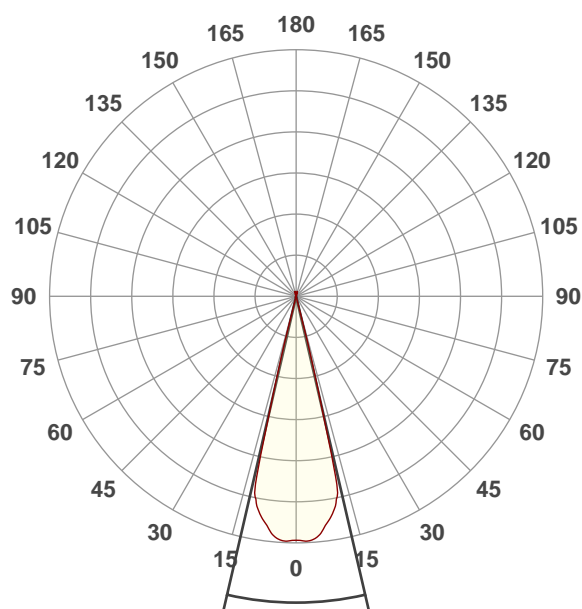

Beam angle 50%: 26,1°
Field angle 10%: 28,9°
Cut off angle 2.5%: 29,5°

Spectra

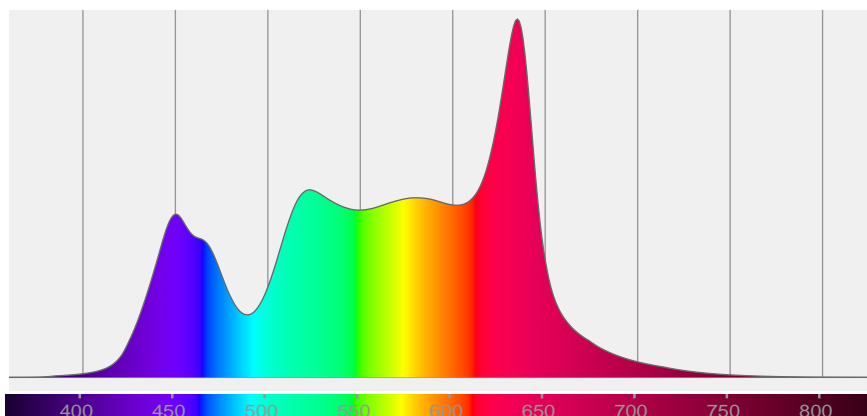

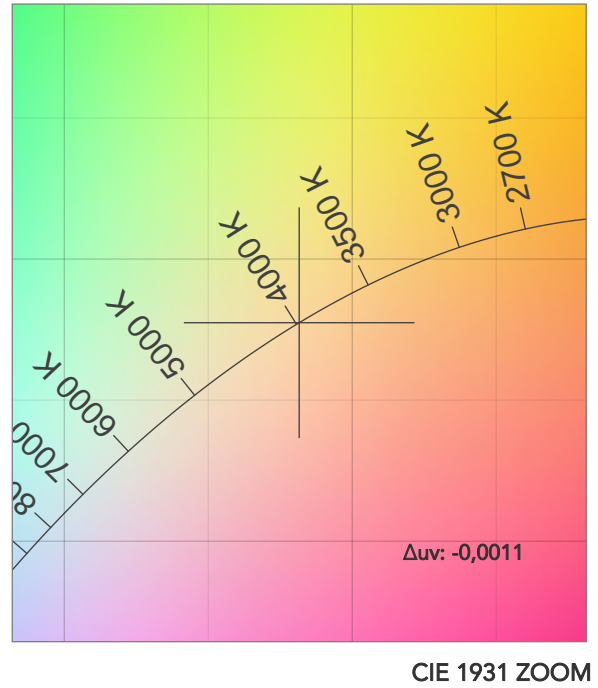
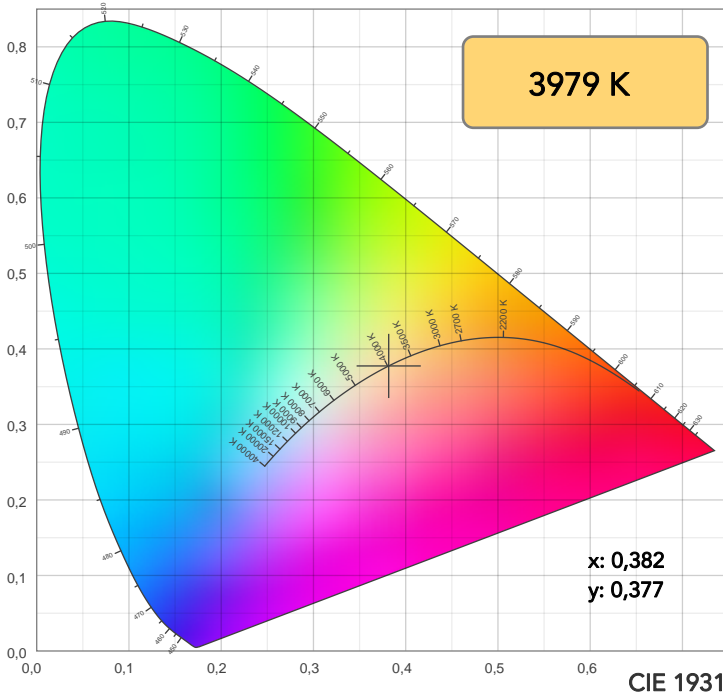

TM30: 92,5

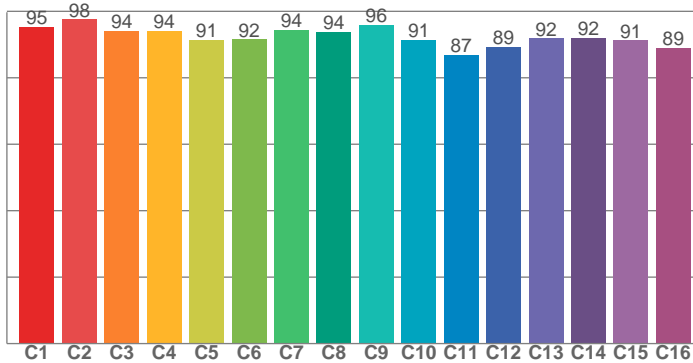

CRI: 95,3 (R1-R8)

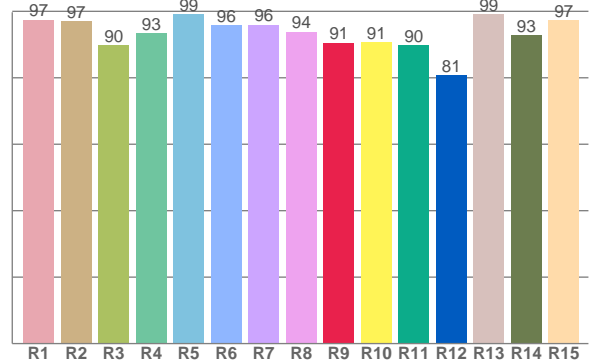

CRI R values, only R1-R8 are used to calculate final CRI value

R1	R2	R3	R4	R5	R6	R7	R8	R9	R10	R11	R12	R13	R14	R15
97,4	97,0	89,7	93,4	99,2	95,8	96,0	93,9	90,5	90,8	89,9	80,7	99,0	92,8	97,4

TM30 C values, 16 binned values out of total of 99 C values

C1	C2	C3	C4	C5	C6	C7	C8	C9	C10	C11	C12	C13	C14	C15	C16
95,3	97,6	94,1	94,2	91,4	91,6	94,4	93,7	95,9	91,3	87,0	89,3	91,8	92,0	91,2	88,9

CQS Q values

Q1	Q2	Q3	Q4	Q5	Q6	Q7	Q8	Q9	Q10	Q11	Q12	Q13	Q14	Q15
99,7	98,5	88,3	92,1	97,4	94,3	93,3	99,0	94,6	94,4	97,7	99,5	98,1	98,2	99,3

CQS: 95,1

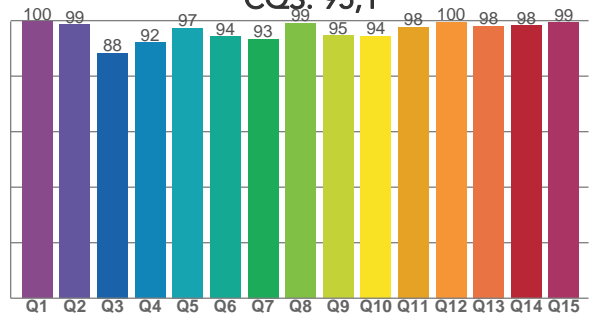

COLOR PARAMETERS

Color temperature	Color rendering index	Red component	Color fidelity	Color gamut	Color quality scale	Television lighting index	Color coordinate cie 1931	Color coordinate cie 1931	Color deviation from black body
CCT	CRI	CRI R9	TM30 Rf	TM30 Rg	CQS	TLCI	x	y	Δuv
3979 K	95,3	90,5	92,5	103,6	95,1	91	0,382	0,377	-0,0011

TM30 DETAILS

Rf 92,5
Fidelity index Rf

Rg 103,6
Gammut index

Hue Bin	R _f	Graphic shifts (%)	
		Chroma	Hue
1	95	0%	-1%
2	98	0%	0%
3	94	0%	2%
4	94	0%	2%
5	91	1%	3%
6	92	4%	3%
7	94	3%	0%
8	94	1%	0%
9	96	0%	2%
10	91	-2%	4%
11	87	2%	7%
12	89	4%	3%
13	92	5%	-2%
14	92	6%	3%
15	91	4%	-2%
16	89	3%	-5%

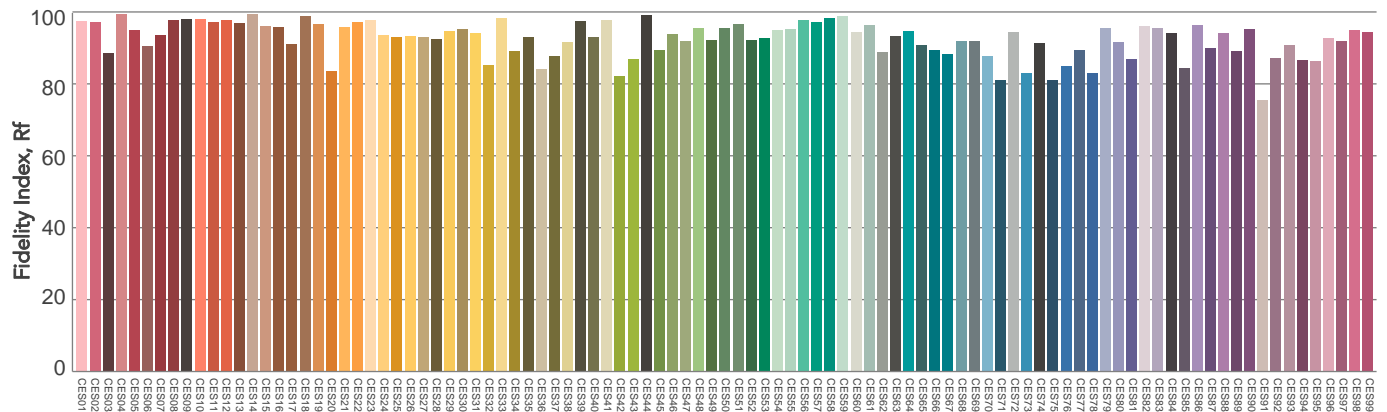
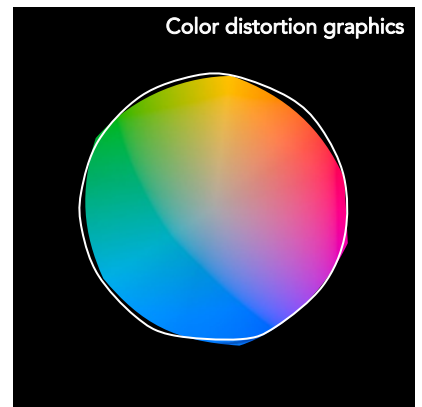
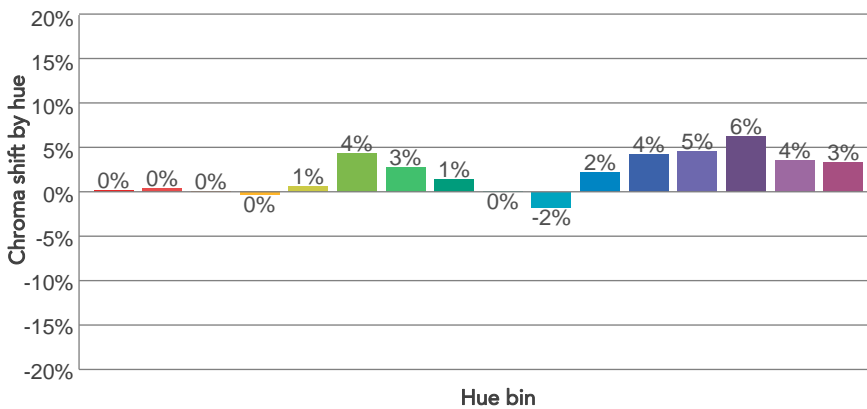
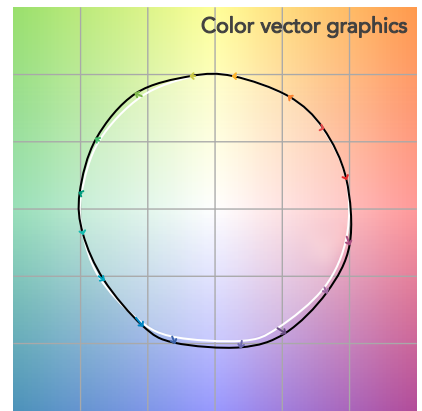
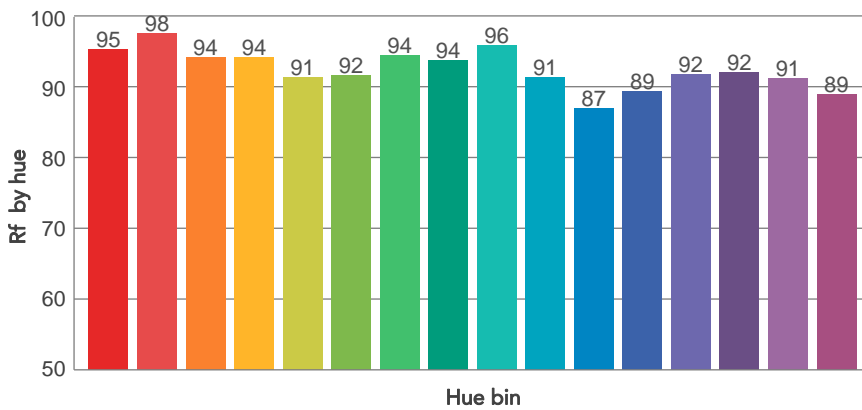
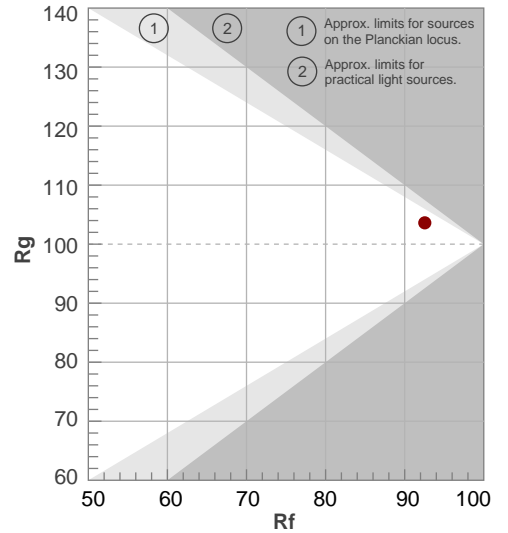

Color Evaluation Sample

BEAM DETAILS



Beam angle 50%	Field angle 10%	Cut off angle 2,5%	Intensity ratio in 120° cone	Intensity ratio in 90° cone
26,1°	28,9°	29,5°	100,0%	100,0%

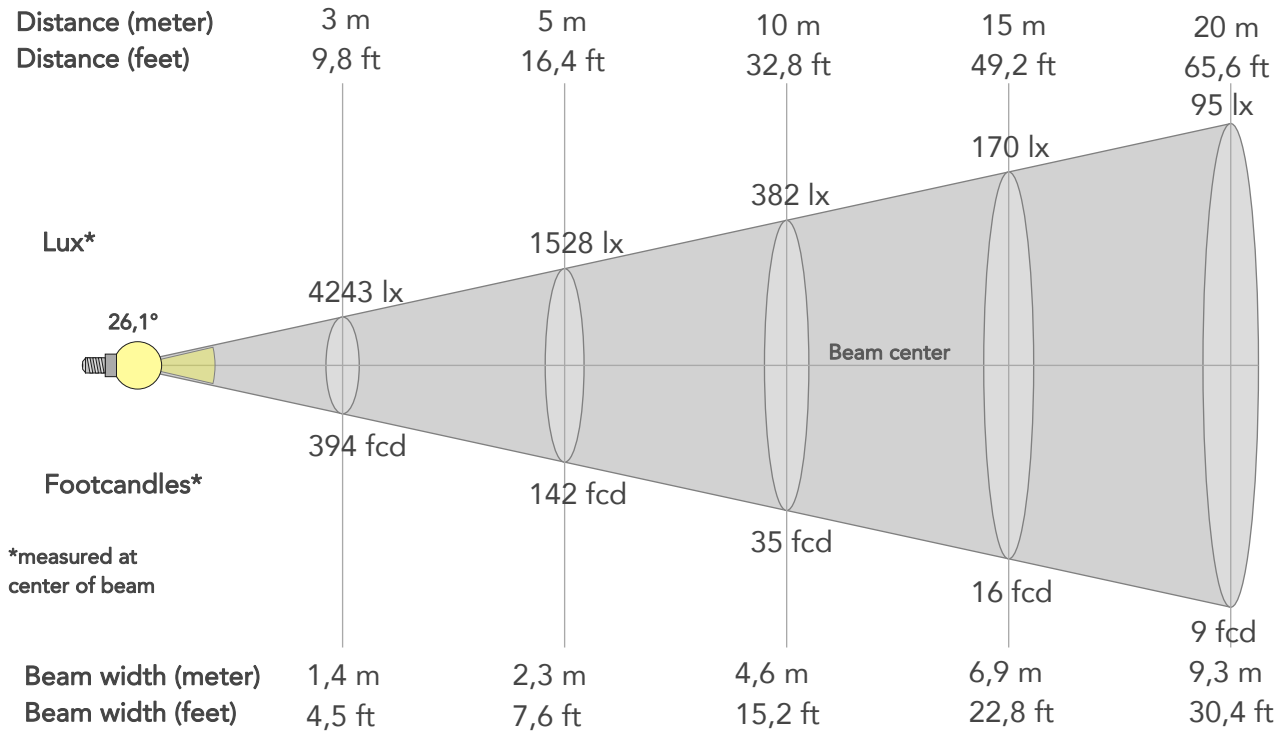

BEAM INTENSITIES AND WIDTHS

Distance	1m	2m	3m	4m	5m	7,5m	10m	15m	20m	25m	30m	40m	50m
Distance	3,3ft	6,6ft	9,8ft	13,1ft	16,4ft	24,6ft	32,8ft	49,2ft	65,6ft	82ft	98,4ft	131,2ft	164ft
Lux	38188lx	9547lx	4243lx	2387lx	1528lx	679lx	382lx	170lx	95lx	61lx	42lx	24lx	15lx
Footcand.	3548fcd	887fcd	394fcd	222fcd	142fcd	63fcd	35fcd	16fcd	9fcd	6fcd	4fcd	2fcd	1fcd
Beam wid.	0,5m	0,9m	1,4m	1,9m	2,3m	3,5m	4,6m	6,9m	9,3m	11,6m	13,9m	18,5m	23,1m
Beam wid.	1,5ft	3,1ft	4,5ft	6,1ft	7,6ft	11,4ft	15,2ft	22,8ft	30,4ft	37,9ft	45,5ft	60,7ft	75,9ft

LINEAR DISTRIBUTION DIAGRAM

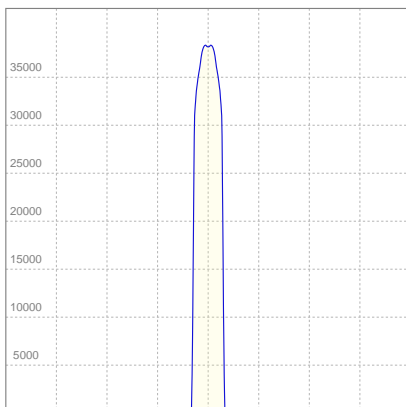

ELECTRICAL SPECIFICATIONS

Input voltage	Input current	Input power	Effeciency
226V	0,924A	196,1W	30lm/W

ISO CANDELA DIAGRAM

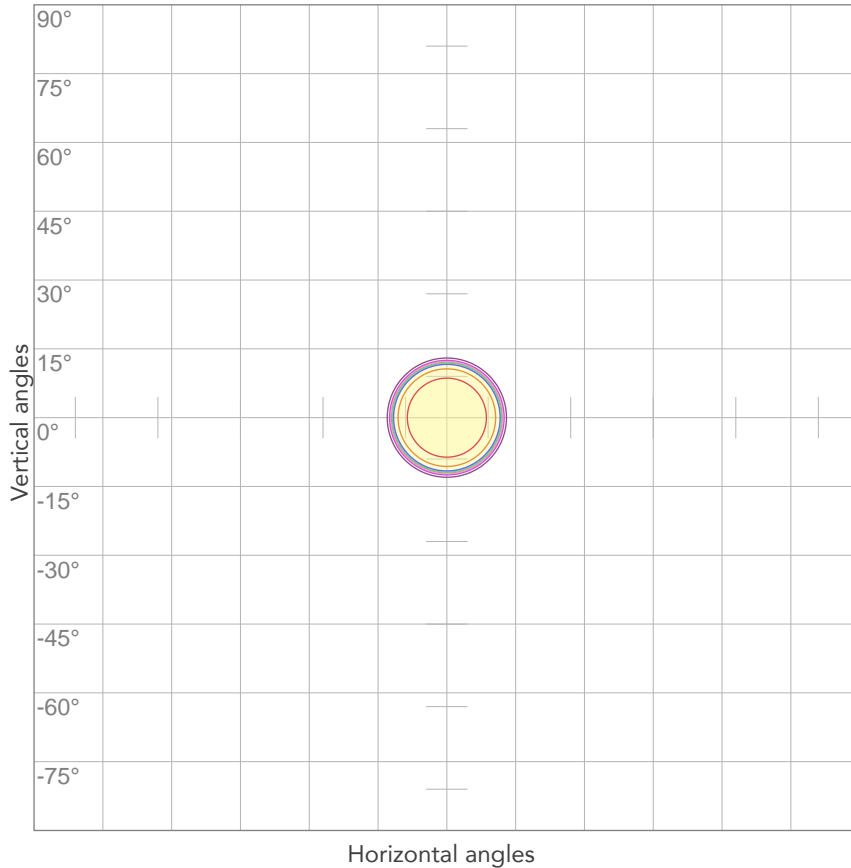

10%	3819 cd
20%	7638 cd
30%	11456 cd
40%	15275 cd
50%	19094 cd
60%	22913 cd
70%	26731 cd
80%	30550 cd

Conditions:

Number of c-planes: 2

Candela at center: 38188 cd

ISO LUX DIAGRAM

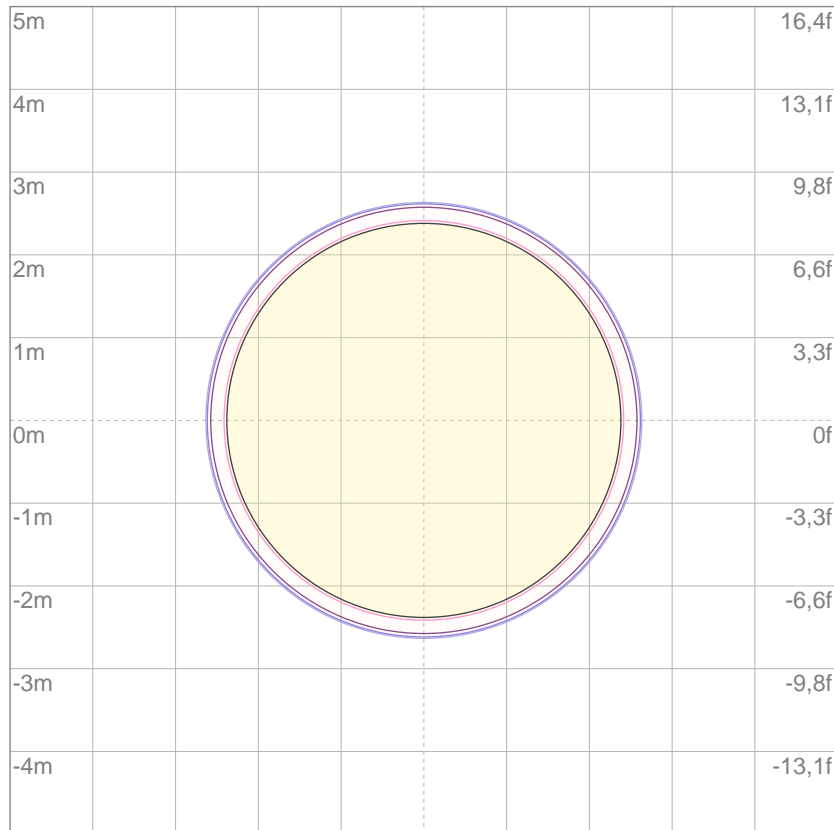

3%	11,5 lx
5%	19,1 lx
10%	38,2 lx
30%	115 lx
50%	191 lx

Conditions:

Number of c-planes: 2

Lux at center: 382 lx

Lux distribution on a surface when lamp is mounted at 10 meters from the surface.

Mounting height: 10 meters (33 feet)



Total lumen output:

6301 lm

Peak candela output:

41741 cd

Light quality:

CRI: 96,9

Color temperature:

5636 K

PRODUCT NAME:

ECLCTPLUS

MEASURAMENT CONDITIONS:

Beam angle:

PRL26

Target:

5600K HQ

Operator:

Paolo Carvone

Date and time:

14/07/2020 11:46:35

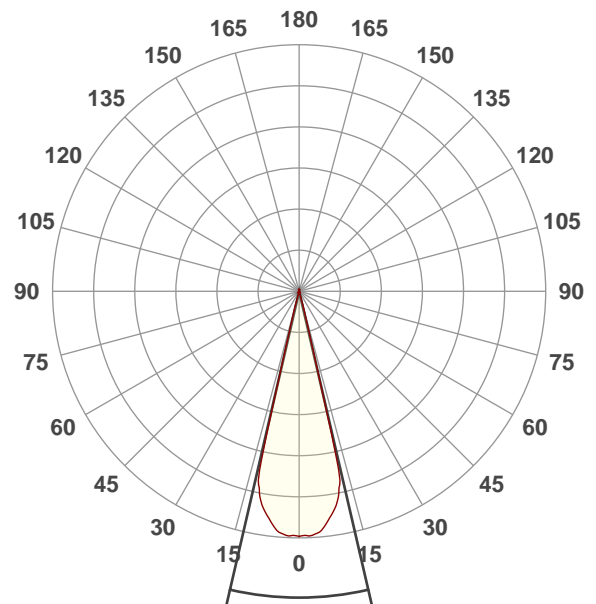

Spectra

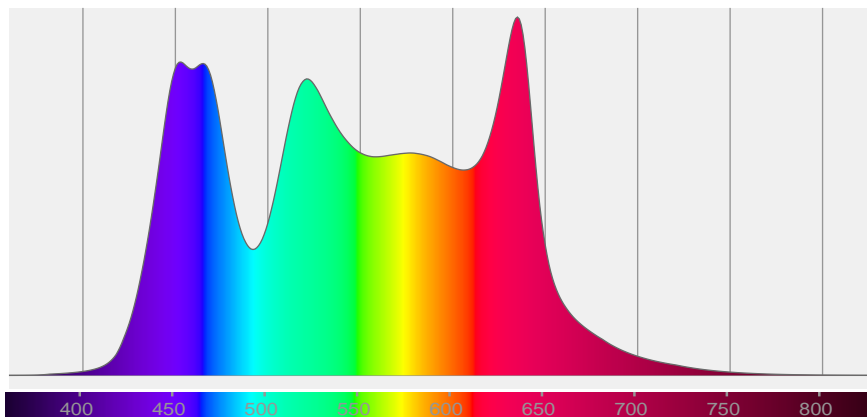

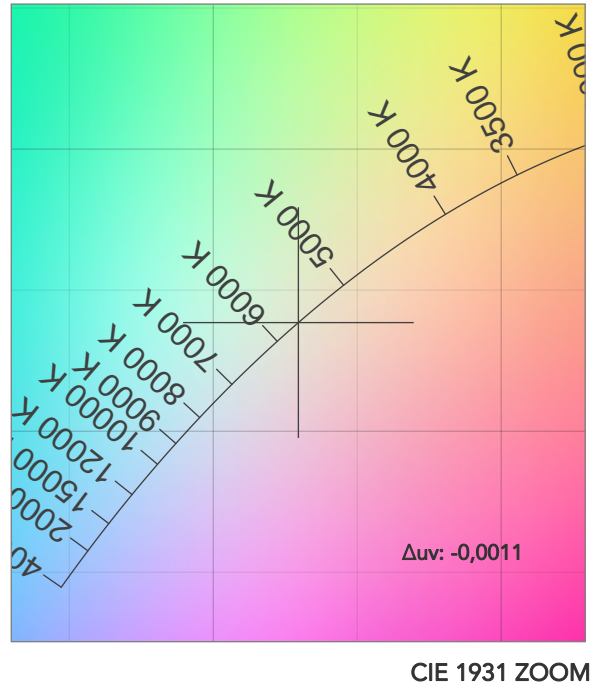
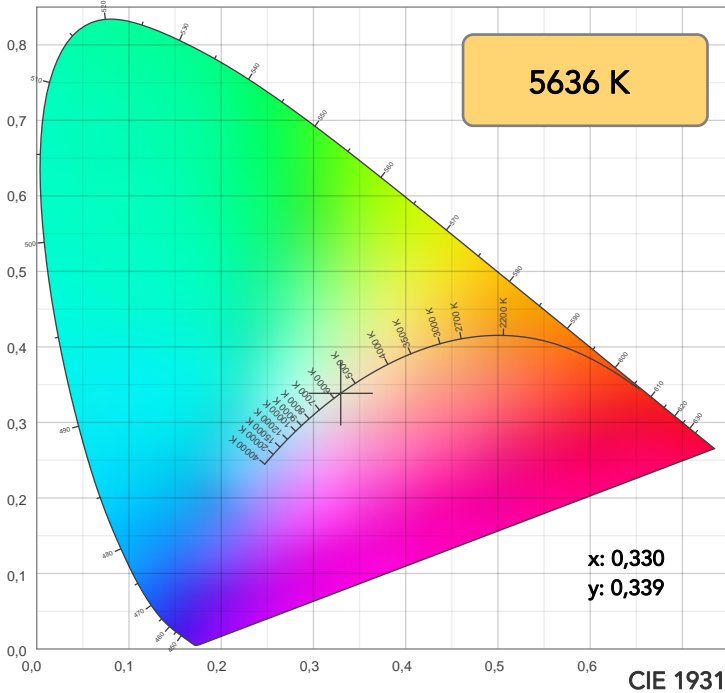

TM30: 91,8

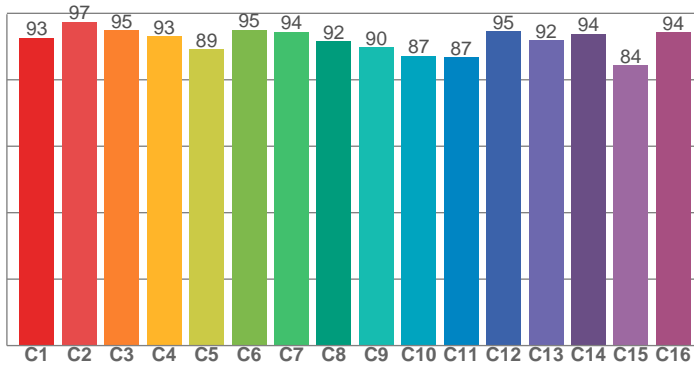

CRI: 96,9 (R1-R8)

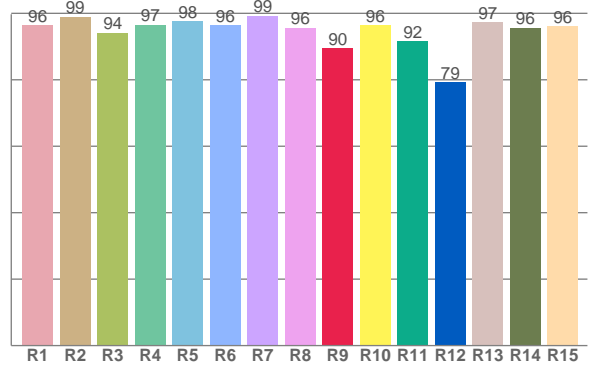

CRI R values, only R1-R8 are used to calculate final CRI value

R1	R2	R3	R4	R5	R6	R7	R8	R9	R10	R11	R12	R13	R14	R15
96,3	99,0	94,2	96,6	97,6	96,5	99,3	95,7	89,6	96,4	91,7	79,3	97,2	95,6	96,0

TM30 C values, 16 binned values out of total of 99 C values

C1	C2	C3	C4	C5	C6	C7	C8	C9	C10	C11	C12	C13	C14	C15	C16
92,7	97,4	94,9	93,0	89,2	95,1	94,5	91,6	89,7	87,1	86,7	94,6	91,8	93,8	84,3	94,3

CQS Q values

Q1	Q2	Q3	Q4	Q5	Q6	Q7	Q8	Q9	Q10	Q11	Q12	Q13	Q14	Q15
95,6	98,2	90,8	91,8	96,2	99,6	97,5	99,2	96,0	96,9	99,7	98,9	98,2	97,8	97,1

CQS: 96,0

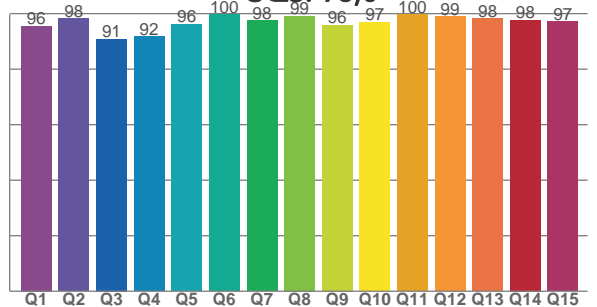

COLOR PARAMETERS

Color temperature	Color rendering index	Red component	Color fidelity	Color gamut	Color quality scale	Television lighting index	Color coordinate cie 1931	Color coordinate cie 1931	Color deviation from black body
CCT	CRI	CRI R9	TM30 Rf	TM30 Rg	CQS	TLCI	x	y	Δuv
5636 K	96,9	89,6	91,8	100,6	96,0	95	0,330	0,339	-0,0011

TM30 DETAILS

Rf 91,8
Fidelity index Rf

Rg 100,6
Gammut index

Hue Bin	R _f	Graphic shifts (%)	
		Chroma	Hue
1	93	0%	1%
2	97	1%	0%
3	95	0%	-2%
4	93	-3%	-2%
5	89	-5%	0%
6	95	0%	2%
7	94	-1%	2%
8	92	-1%	4%
9	90	-1%	8%
10	87	0%	7%
11	87	4%	6%
12	95	3%	-1%
13	92	3%	-3%
14	94	1%	-1%
15	84	7%	-7%
16	94	1%	-1%

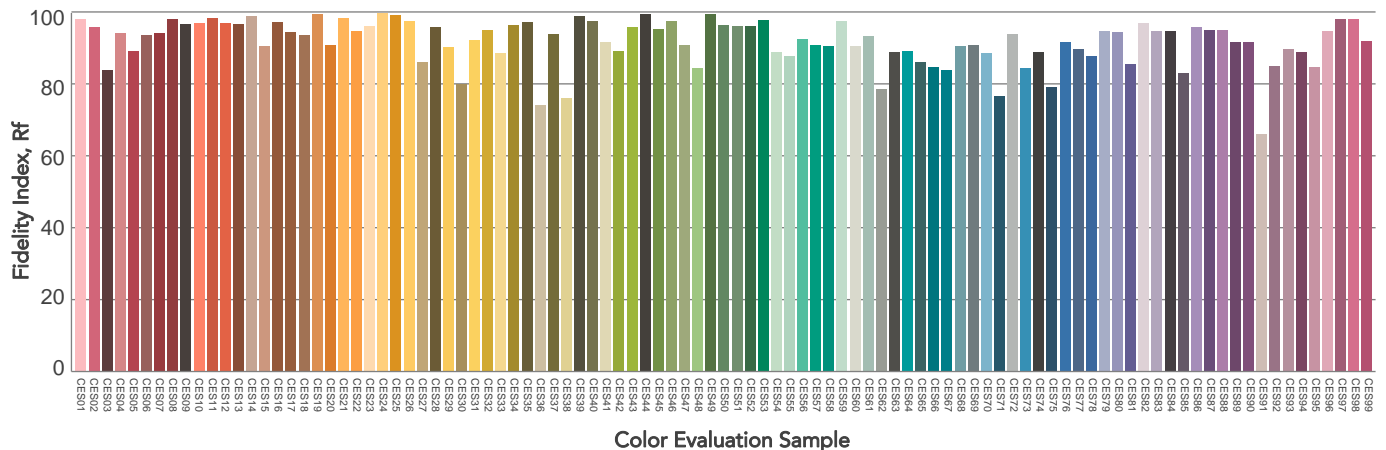
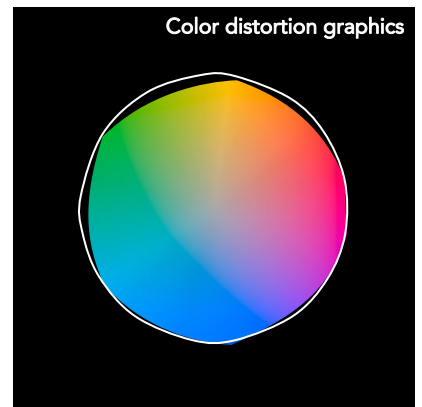
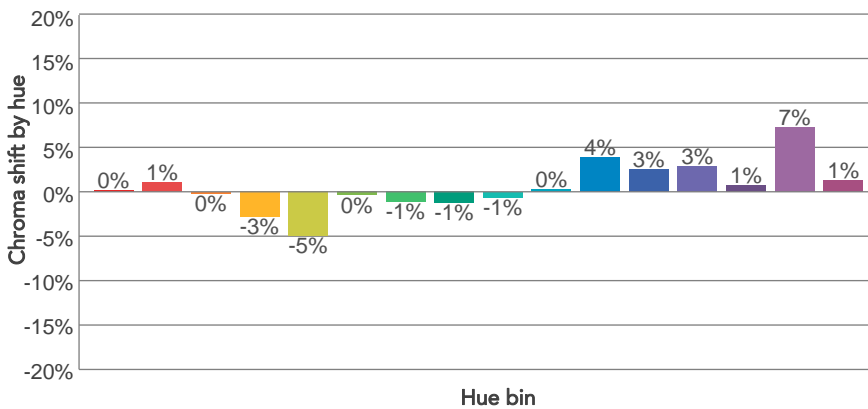
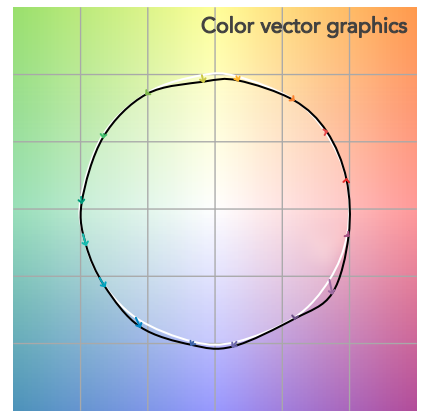
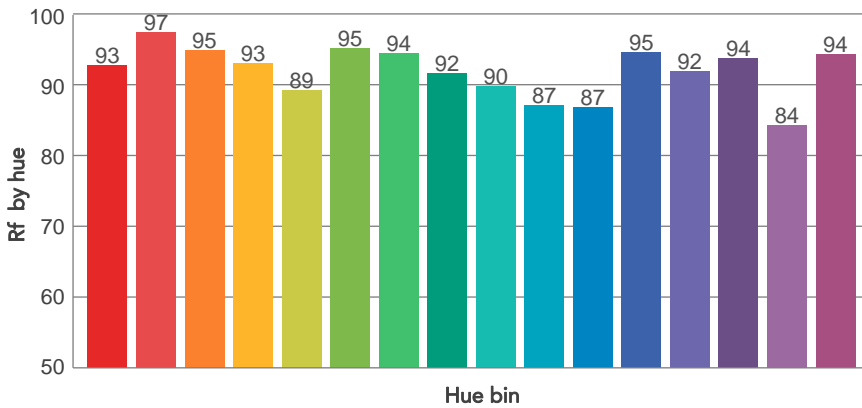
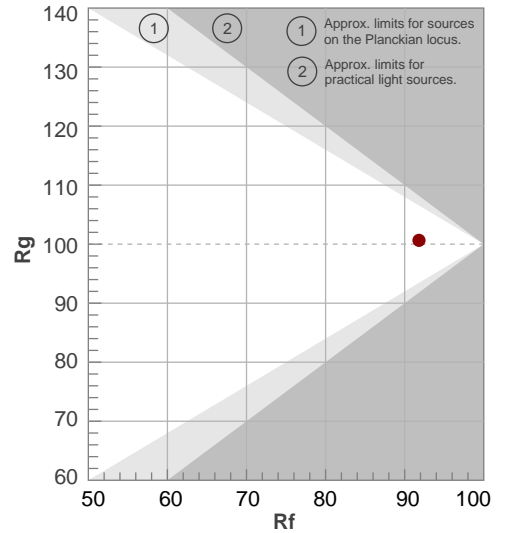

BEAM DETAILS



Beam angle 50%	Field angle 10%	Cut off angle 2,5%	Intensity ratio in 120° cone	Intensity ratio in 90° cone
26,1°	28,4°	29,8°	100,0%	100,0%

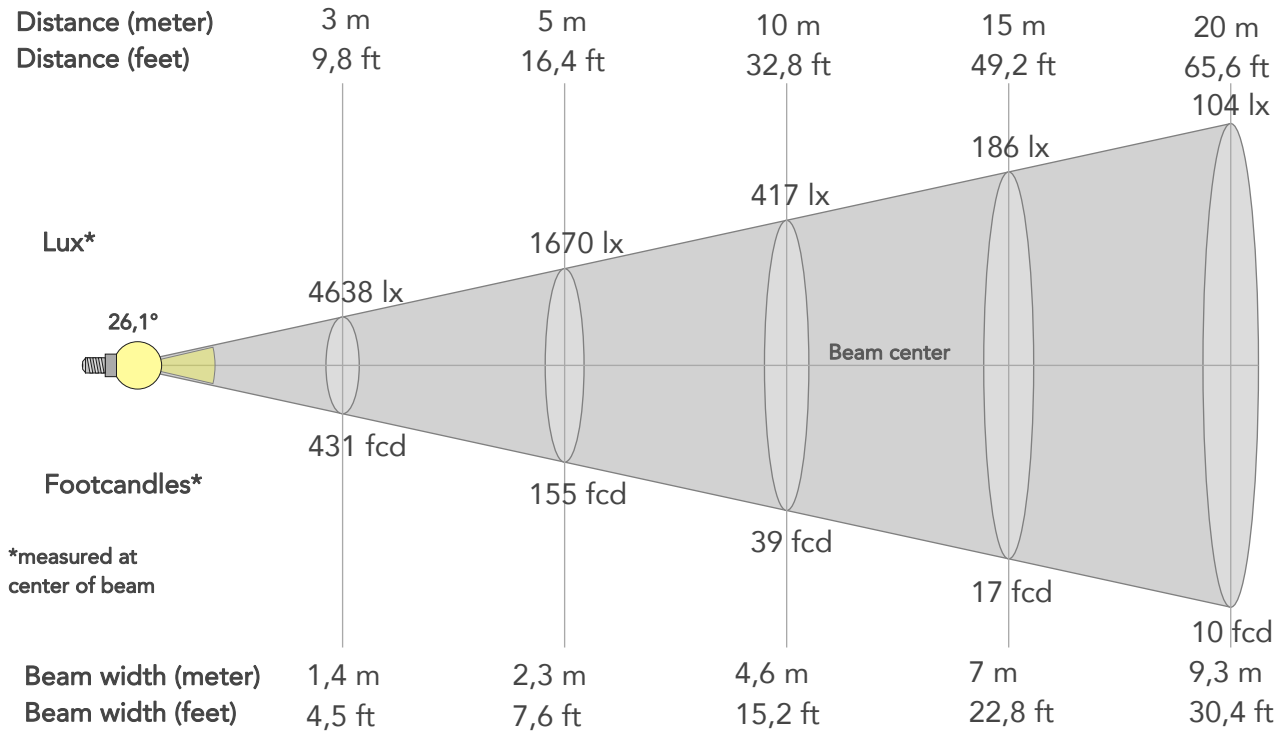

BEAM INTENSITIES AND WIDTHS

Distance	1m	2m	3m	4m	5m	7,5m	10m	15m	20m	25m	30m	40m	50m
Distance	3,3ft	6,6ft	9,8ft	13,1ft	16,4ft	24,6ft	32,8ft	49,2ft	65,6ft	82ft	98,4ft	131,2ft	164ft
Lux	41741lx	10435lx	4638lx	2609lx	1670lx	742lx	417lx	186lx	104lx	67lx	46lx	26lx	17lx
Footcand.	3878fcd	969fcd	431fcd	242fcd	155fcd	69fcd	39fcd	17fcd	10fcd	6fcd	4fcd	2fcd	2fcd
Beam wid.	0,5m	0,9m	1,4m	1,9m	2,3m	3,5m	4,6m	7m	9,3m	11,6m	13,9m	18,5m	23,2m
Beam wid.	1,5ft	3,1ft	4,5ft	6,1ft	7,6ft	11,4ft	15,2ft	22,8ft	30,4ft	38ft	45,6ft	60,8ft	76ft

LINEAR DISTRIBUTION DIAGRAM

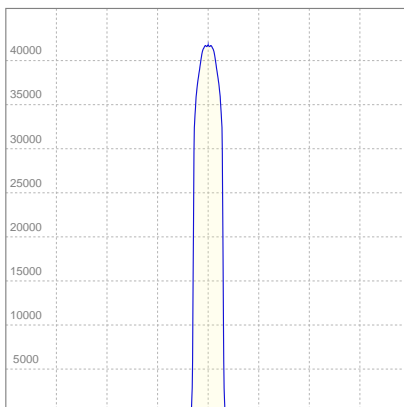

ELECTRICAL SPECIFICATIONS

Input voltage	Input current	Input power	Effeciency
226V	1,05A	225,3W	28lm/W

ISO CANDELA DIAGRAM

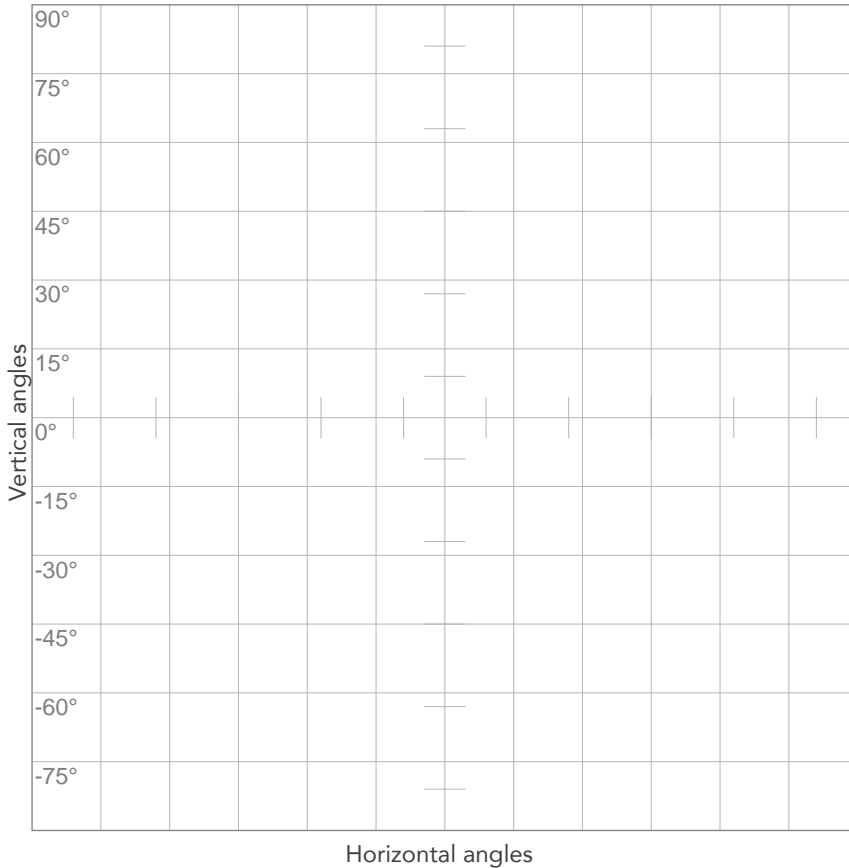

10%	4174 cd
20%	8348 cd
30%	12522 cd
40%	16696 cd
50%	20870 cd
60%	25045 cd
70%	29219 cd
80%	33393 cd

Conditions:

Number of c-planes: 2

Candela at center: 41741 cd

ISO LUX DIAGRAM

45m	147,6f
36m	118,1f
27m	88,6f
18m	59,1f
9m	29,5f
0m	0f
-9m	-29,5f
-18m	-59,1f
-27m	-88,6f
-36m	-118,1f

Mounting height: 10 meters (33 feet)

3%	12,5 lx
5%	20,9 lx
10%	41,7 lx
30%	125 lx
50%	209 lx

Conditions:

Number of c-planes: 2

Lux at center: 417 lx

Lux distribution on a surface when lamp is mounted at 10 meters from the surface.



Total lumen output:

6339 lm

Peak candela output:

41906 cd

Light quality:

CRI: 96,9

Color temperature:

5988 K

PRODUCT NAME:

ECLCTPLUS

MEASURAMENT CONDITIONS:

Beam angle:

PRL26

Target:

6000K HQ

Operator:

Paolo Carvone

Date and time:

14/07/2020 11:48:29

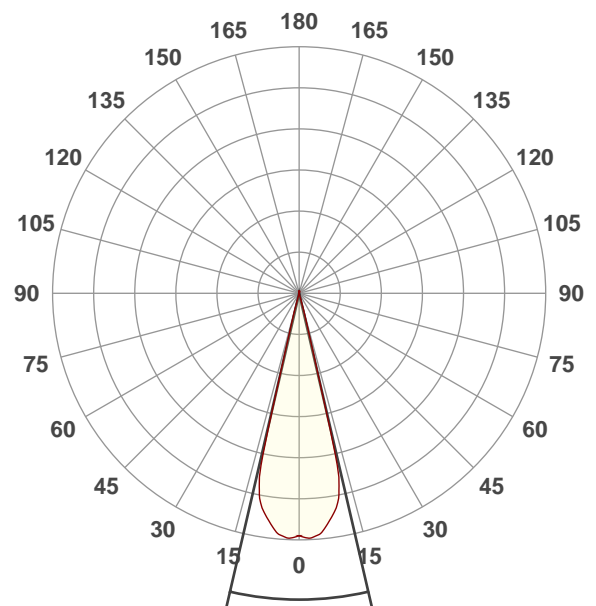

Spectra

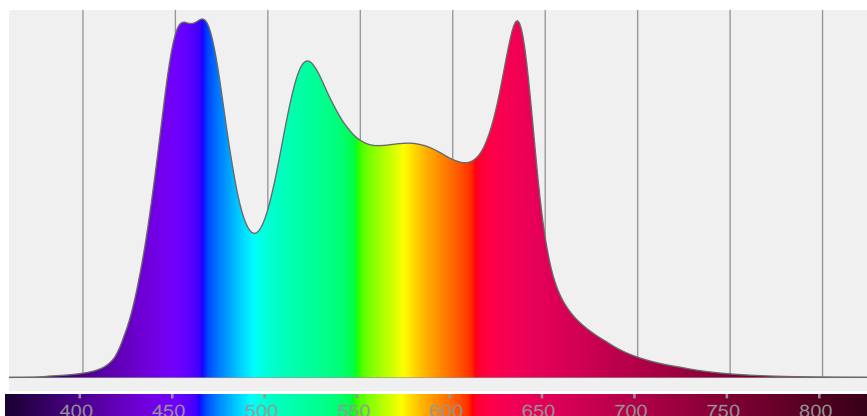

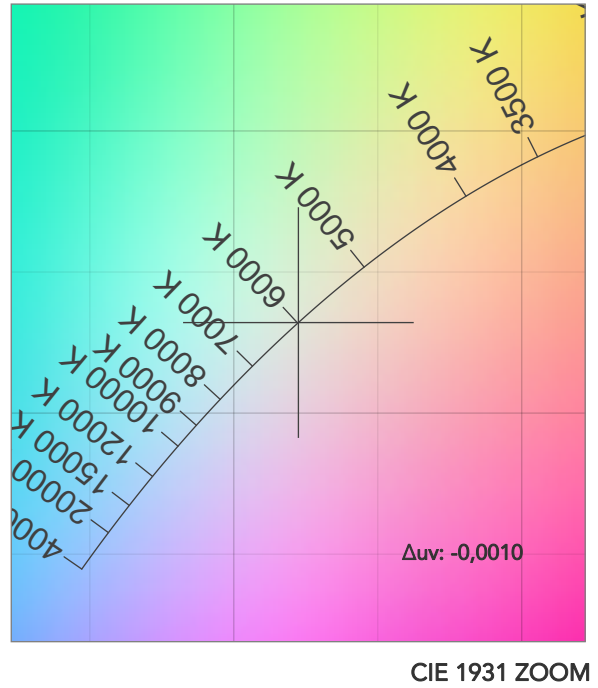
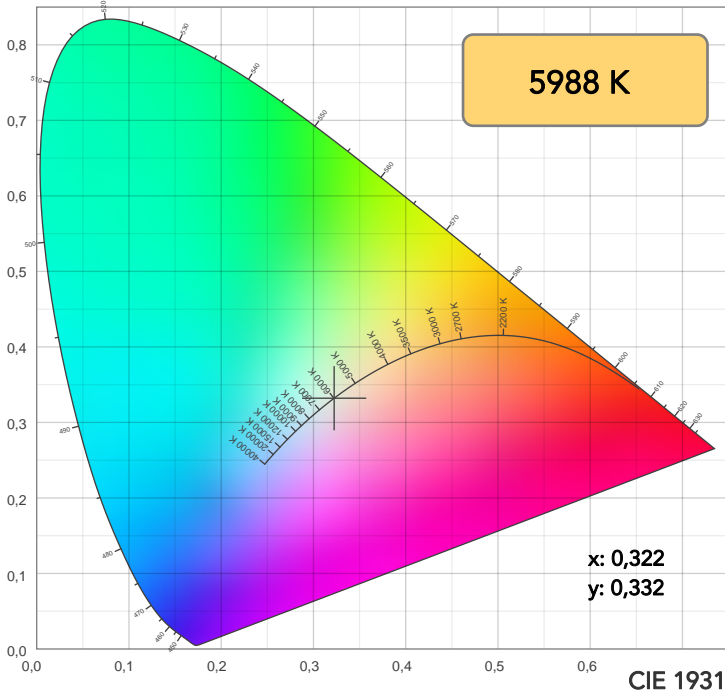

TM30: 92,0

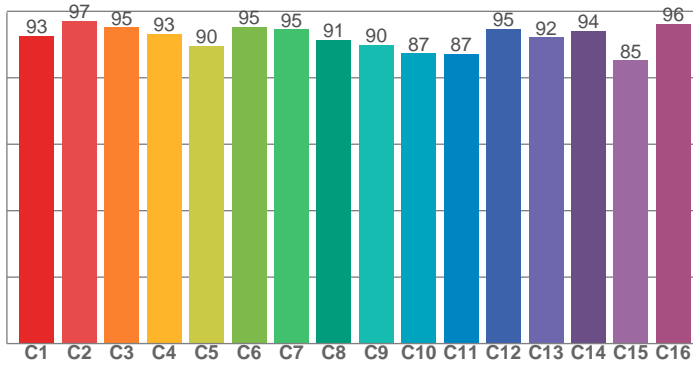

CRI: 96,9 (R1-R8)

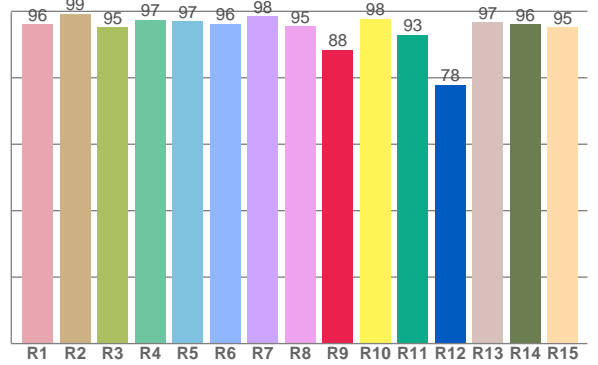

CRI R values, only R1-R8 are used to calculate final CRI value

R1	R2	R3	R4	R5	R6	R7	R8	R9	R10	R11	R12	R13	R14	R15
96,0	99,3	95,1	97,5	97,0	96,3	98,4	95,5	88,5	97,8	92,9	77,9	96,7	96,1	95,2

TM30 C values, 16 binned values out of total of 99 C values

C1	C2	C3	C4	C5	C6	C7	C8	C9	C10	C11	C12	C13	C14	C15	C16
92,6	97,2	95,1	93,3	89,6	95,3	94,6	91,5	89,8	87,4	87,3	94,7	92,2	94,0	85,2	96,2

CQS Q values

Q1	Q2	Q3	Q4	Q5	Q6	Q7	Q8	Q9	Q10	Q11	Q12	Q13	Q14	Q15
94,3	97,9	91,3	91,2	95,0	98,2	98,2	99,3	96,4	97,6	99,7	98,6	98,1	97,6	96,5

CQS: 95,8

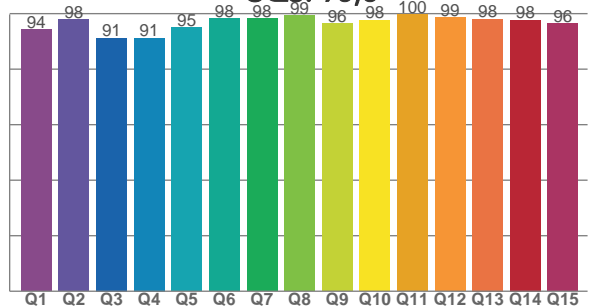

COLOR PARAMETERS

Color temperature	Color rendering index	Red component	Color fidelity	Color gamut	Color quality scale	Television lighting index	Color coordinate cie 1931	Color coordinate cie 1931	Color deviation from black body
CCT	CRI	CRI R9	TM30 Rf	TM30 Rg	CQS	TLCI	x	y	Δuv
5988 K	96,9	88,5	92,0	100,7	95,8	96	0,322	0,332	-0,0010

TM30 DETAILS



Rf 92,0
Fidelity index Rf

Rg 100,7
Gammut index

Hue Bin	R _f	Graphic shifts (%)	
		Chroma	Hue
1	93	0%	1%
2	97	1%	0%
3	95	0%	-1%
4	93	-3%	-2%
5	90	-5%	0%
6	95	0%	2%
7	95	-1%	2%
8	91	-1%	4%
9	90	0%	8%
10	87	0%	7%
11	87	4%	6%
12	95	3%	-1%
13	92	3%	-3%
14	94	1%	-1%
15	85	8%	-7%
16	96	0%	1%

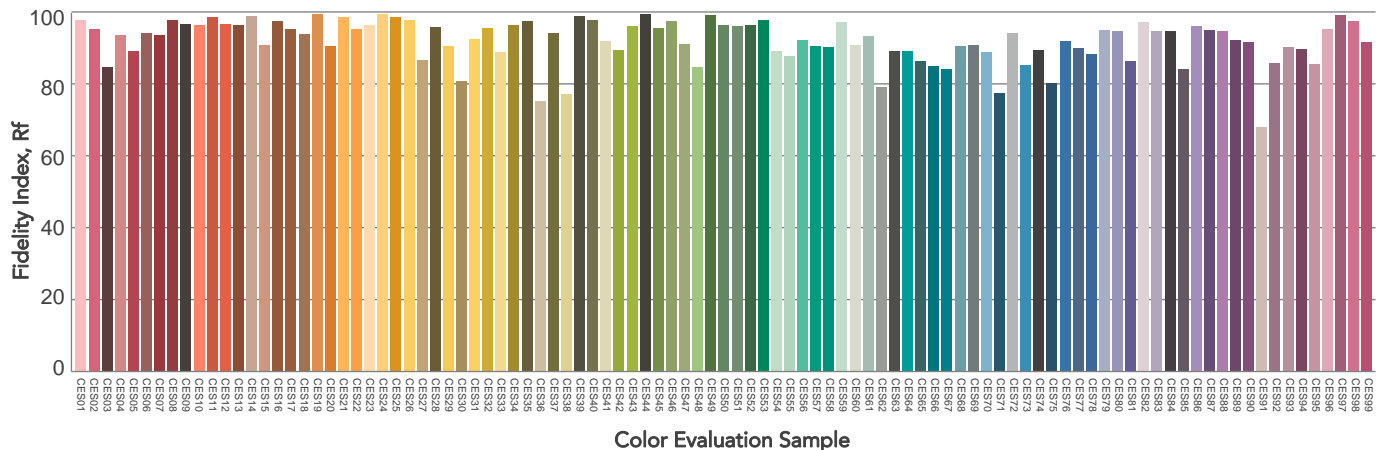
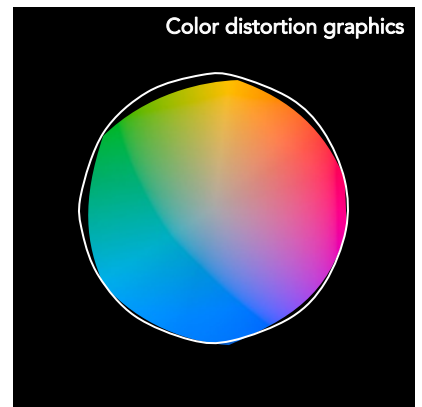
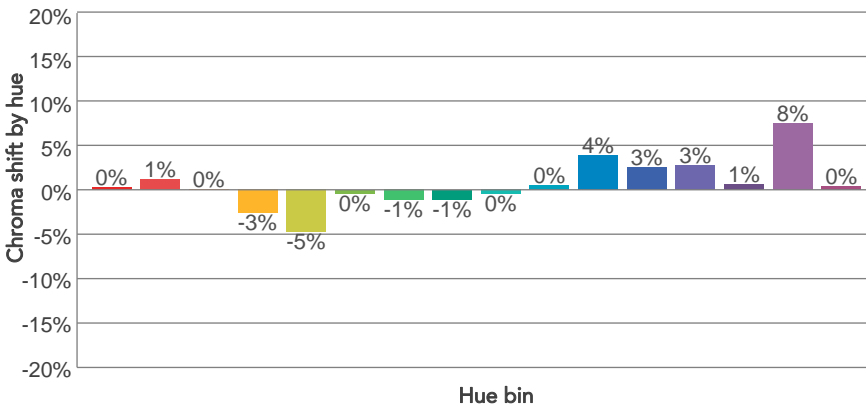
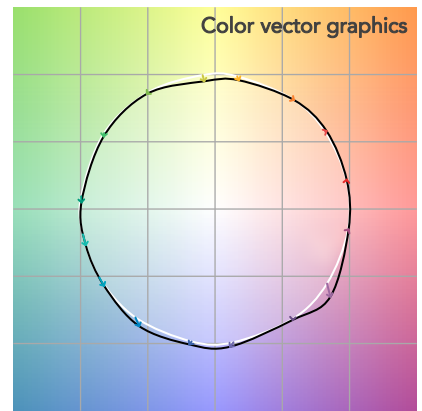
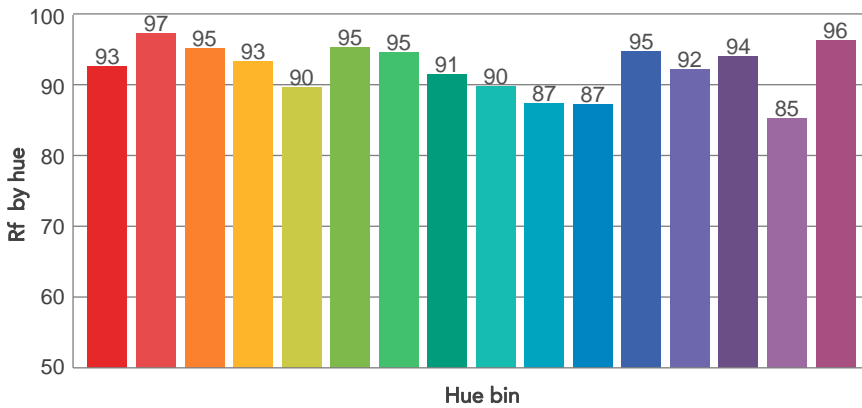
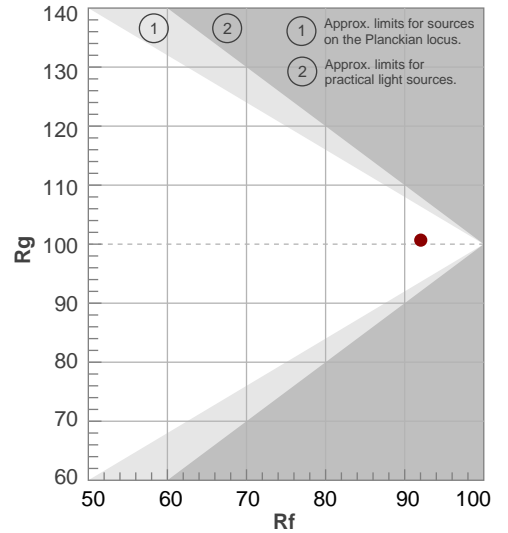

BEAM DETAILS



Beam angle 50%	Field angle 10%	Cut off angle 2,5%	Intensity ratio in 120° cone	Intensity ratio in 90° cone
26,1°	28,6°	29,9°	100,0%	100,0%

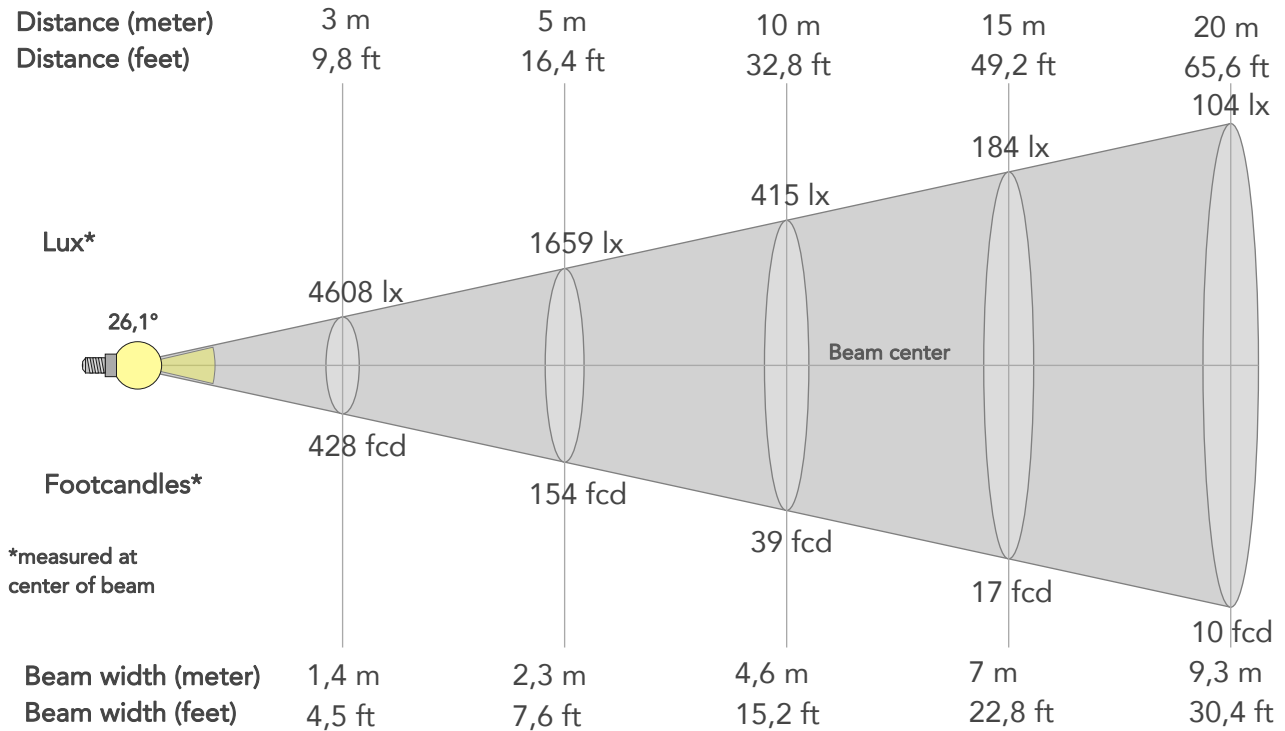

BEAM INTENSITIES AND WIDTHS

Distance	1m	2m	3m	4m	5m	7,5m	10m	15m	20m	25m	30m	40m	50m
Distance	3,3ft	6,6ft	9,8ft	13,1ft	16,4ft	24,6ft	32,8ft	49,2ft	65,6ft	82ft	98,4ft	131,2ft	164ft
Lux	41475lx	10369lx	4608lx	2592lx	1659lx	737lx	415lx	184lx	104lx	66lx	46lx	26lx	17lx
Footcand.	3853fcd	963fcd	428fcd	241fcd	154fcd	69fcd	39fcd	17fcd	10fcd	6fcd	4fcd	2fcd	2fcd
Beam wid.	0,5m	0,9m	1,4m	1,9m	2,3m	3,5m	4,6m	7m	9,3m	11,6m	13,9m	18,5m	23,2m
Beam wid.	1,5ft	3,1ft	4,5ft	6,1ft	7,6ft	11,4ft	15,2ft	22,8ft	30,4ft	38ft	45,6ft	60,8ft	76ft

LINEAR DISTRIBUTION DIAGRAM

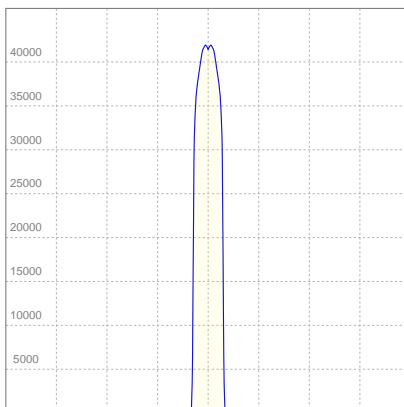

ELECTRICAL SPECIFICATIONS

Input voltage	Input current	Input power	Effeciency
226V	1,07A	229,7W	28lm/W

ISO CANDELA DIAGRAM

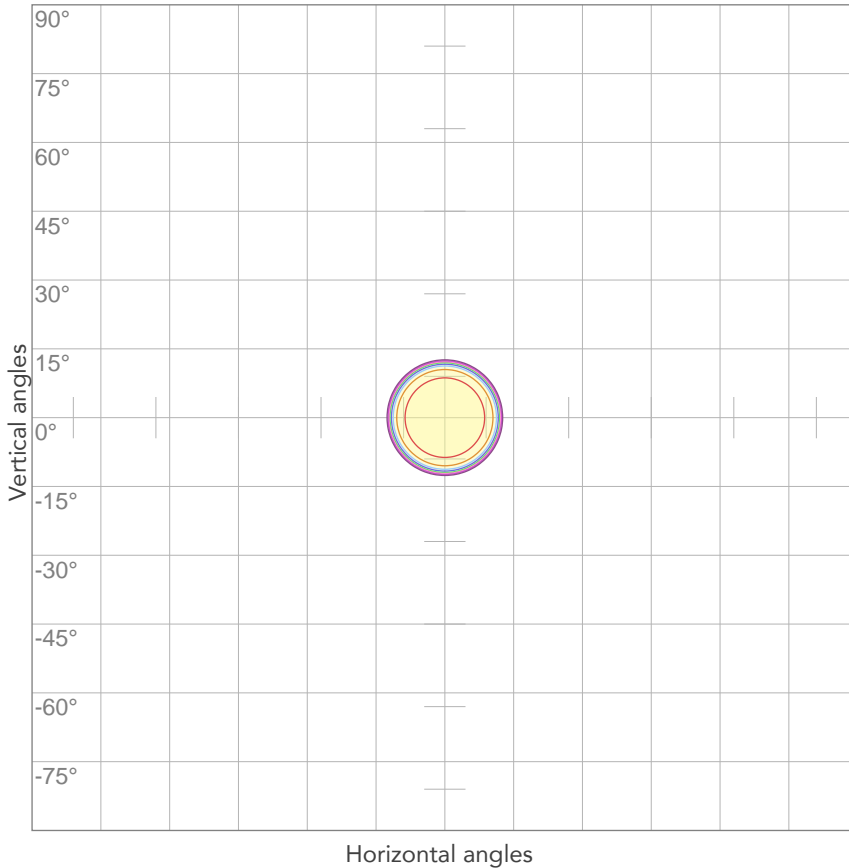

10%	4148 cd
20%	8295 cd
30%	12443 cd
40%	16590 cd
50%	20738 cd
60%	24885 cd
70%	29033 cd
80%	33180 cd

Conditions:

Number of c-planes: 2

Candela at center: 41475 cd

ISO LUX DIAGRAM

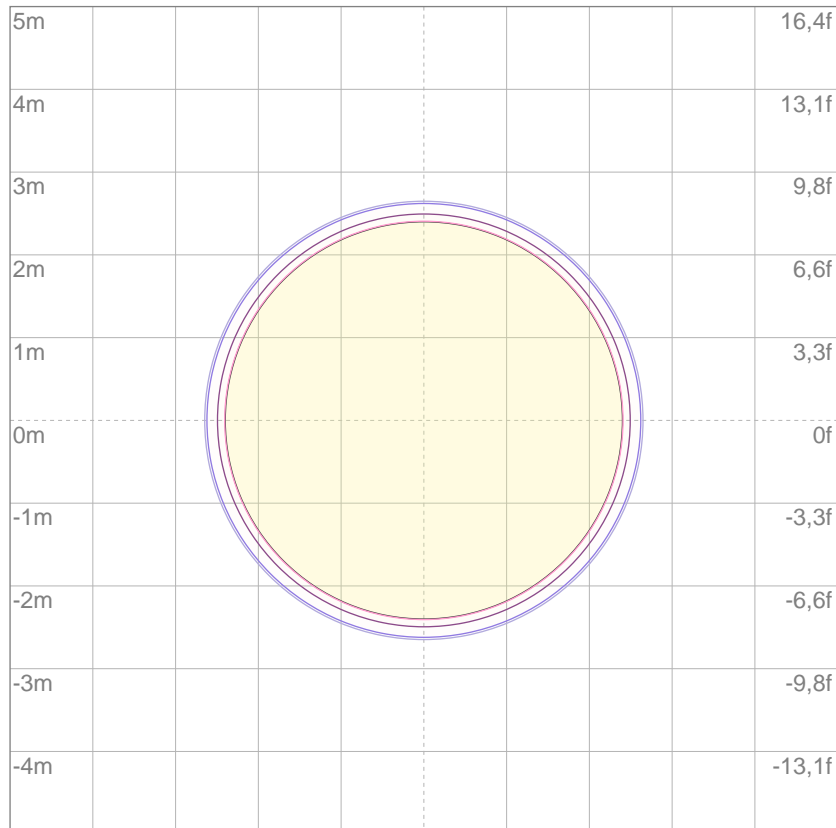

3%	12,4 lx
5%	20,7 lx
10%	41,5 lx
30%	124 lx
50%	207 lx

Conditions:

Number of c-planes: 2

Lux at center: 415 lx

Lux distribution on a surface when lamp is mounted at 10 meters from the surface.

Mounting height: 10 meters (33 feet)